



barka.it

## Products **Prodotti** 2024

Attrezzature  
e accessori per la nautica

Equipment  
and accessories for boating





# Benvenuti a bordo!

---

BARKA opera dal 1966 con successo nel settore della nautica da diporto: dalla vendita di barche a vela, sua principale attività originaria, si è via via specializzata nella produzione e distribuzione di attrezzature e accessori nautici.

Con sede principale a Milano, un'unità produttiva a Bergamo e distributori all'estero, nel corso dei suoi anni di attività si è affermata come una delle realtà più serie, affidabili e versatili del settore, diventando punto di riferimento per gli approvvigionamenti da parte dei principali cantieri e operatori nazionali ed internazionali.

Suo punto di forza è, innanzitutto, l'unicità degli articoli di propria produzione: il TEAK WONDER, linea di prodotti leader a livello internazionale nel settore dei prodotti di pulizia e cura del teak, ed i SUPPORTI e gli ATTUATORI ELETTRICI, venduti in tutto il mondo anche in versioni personalizzate.

BARKA si distingue inoltre per l'elevata qualità dei prodotti per la nautica che distribuisce (rubinetti, lavelli, raccordi, pompe, filtri, ecc.), dei quali può offrire una gamma in grado di soddisfare ogni tipo di esigenza.

# Welcome on board!

---

Since 1966 BARKA operates successfully in the field of pleasure boating: from sale of sailboats, its main original activity, it has gradually specialized in the production and distribution of marine equipment and accessories.

Headquartered in Milan, a production unit in Bergamo and distributors abroad, during its years activity it has established itself as one of the most serious, reliable and versatile realities in the industry, becoming a point of reference for supplies for major national and international shipyards and operators.

Its strength is, first of all, the uniqueness of the articles of its production: the TEAK WONDER, product line which is internationally leader in the field of cleaning and care of the teak, and SUPPORTS and ELECTRIC STRUTS, sold around the world also in customized versions.

Moreover, BARKA is distinguished by the high quality of marine products that distributes (faucets, sinks, fittings, pumps, filters, etc.), of which it can provide a range that will satisfy every need.

LAVELLI & LAVABI / SINKS & BASINS	3
PILETTE E SCARICHI / DRAINS & WASTES	19
RUBINETTERIA / MIXERS & FAUCETS	31
RACCORDI RAPIDI SPEEDFIT / SPEEDFIT PUSH-FIT FITTINGS	79
RACCORDERIA / FITTINGS	83
SUPPORTI TAVOLO E POLTRONA / TABLE & CHAIRS PEDESTALS	87
ATTUATORI ELETTRICI / ELECTRIC STRUTS	121
ALZA TELEVISORI / TV LIFT	135
TEAK WONDER	139
FILTRI ACQUA HYDROPURE / WATER FILTERS HYDROPURE	143
POMPE WHALE	147
WATER WITCH	156
VASI D'ESPANSIONE / ACCUMULATORS	157
PATTUMIERA / WASTE BIN	158
FABBRICATORE DI GHIACCIO / ICE MAKER	158





**LEGENDA / LEGEND**

FORMA DEL BORDO / FLANGE PROFILE



- A** Bordo da incasso  
Inset flange
- C** Bordo da sottopiano  
Under surface flange



**LAVELLI SINGOLI / SINGLE SINKS**

**LI 30.15.15/P**

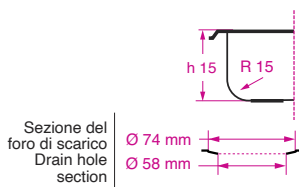
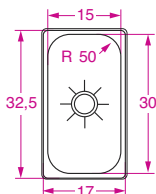

Finitura lucida  
Bordo da incasso tipo **A**  
  
Mirror finish  
Inset flange **A**

LI 30.15.15/P

Peso / Weight 835 g

cod. 01.00.20011

**LI 30.15.18/P**

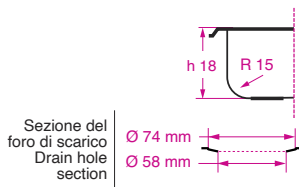
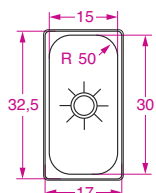

Finitura lucida  
Bordo da incasso tipo **A**  
  
Mirror finish  
Inset flange **A**

LI 30.15.18/P

Peso / Weight 850 g

cod. 01.00.50004

**LI 30.24.15-C/P**

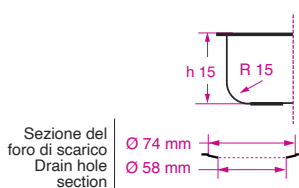
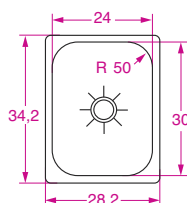

Finitura lucida  
Bordo da sottopiano tipo **C**  
  
Mirror finish  
Under surface flange **C**

LI 30.24.15-C/P

Peso / Weight 1,1 Kg

cod. 01.01.20012

**LI 30.24.15 – LI 30.24.20**

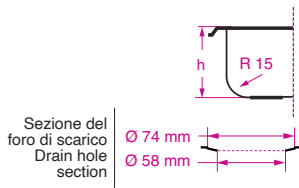
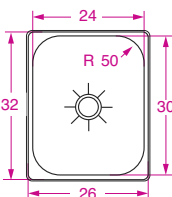

Finitura satinata  
Bordo da incasso tipo **A**  
  
Satin finish  
Inset flange **A**

LI 30.24.15

h 15

Peso / Weight 1,1 Kg

cod. 01.02.20010

LI 30.24.20

h 20

Peso / Weight 1,3 Kg

cod. 01.02.60010

**LI 30.24.15/P – LI 30.24.20/P**

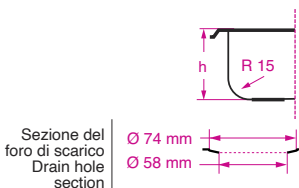
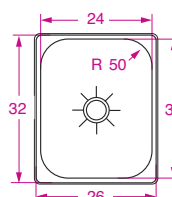

Finitura lucida  
Bordo da incasso tipo **A**  
  
Mirror finish  
Inset flange **A**

LI 30.24.15/P

h 15

Peso / Weight 1,1 Kg

cod. 01.02.20011

LI 30.24.20/P

h 20

Peso / Weight 1,3 Kg

cod. 01.02.60011

Tutte le misure sono espresse in centimetri tranne i raggi che sono espressi in millimetri  
All measurements are in centimeters, except for radius which is in millimeters



**LI 30.33.15 – LI 30.33.20**

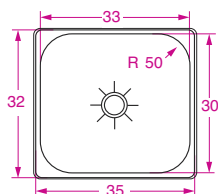

Sezione del foro di scarico  
Drain hole section

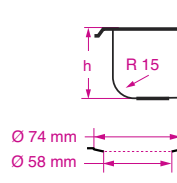

Finitura satinata  
Bordo da incasso tipo A

Satin finish  
Inset flange A

LI 30.33.15

h 15

Peso / Weight 1,4 Kg

cod. 01.04.20010

LI 30.33.20

h 20

Peso / Weight 1,6 Kg

cod. 01.04.60010

**LI 30.33.15/P – LI 30.33.20/P**

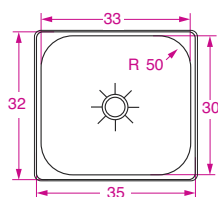

Sezione del foro di scarico  
Drain hole section

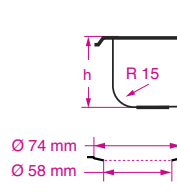

Finitura lucida  
Bordo da incasso tipo A

Mirror finish  
Inset flange A

LI 30.33.15/P

h 15

Peso / Weight 1,4 Kg

cod. 01.04.20014

LI 30.33.20/P

h 20

Peso / Weight 1,6 Kg

cod. 01.04.60011

**LI 33.23.18**

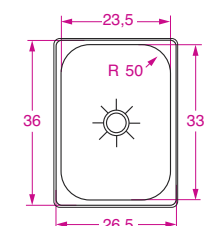

Sezione del foro di scarico  
Drain hole section

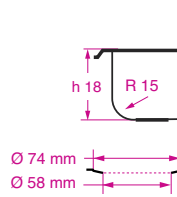

Finitura lucida  
Bordo da incasso tipo A

Mirror finish  
Inset flange A

LI 33.23.18

Peso / Weight 1,4 Kg

cod. 01.05.50003

**LI 33.33.18**

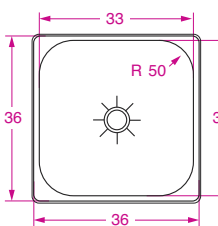

Sezione del foro di scarico  
Drain hole section

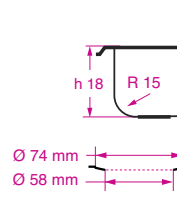

Finitura lucida  
Bordo da incasso tipo A

Mirror finish  
Inset flange A

LI 33.33.18

Peso / Weight 1,5 Kg

cod. 01.06.50003

**LI 33.52.20-C**

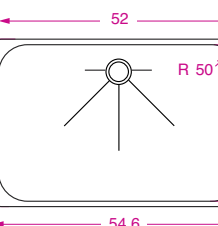

Sezione del foro di scarico  
Drain hole section



Finitura satinata  
Bordo da sottopiano tipo C

Satin finish  
Under surface flange C

LI 33.52.20-C

Peso / Weight 3 Kg

cod. 01.07.63210

Tutte le misure sono espresse in centimetri tranne i raggi che sono espressi in millimetri  
All measurements are in centimeters, except for radius which is in millimeters

**LEGENDA / LEGEND**

FORMA DEL BORDO / FLANGE PROFILE

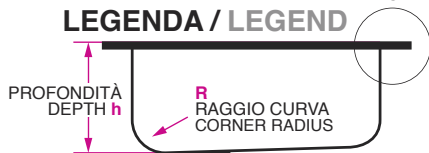

- A** Bordo da incasso  
Inset flange
- C** Bordo da sottopiano  
Under surface flange

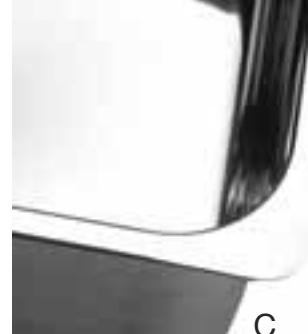

**LAVELLI SINGOLI / SINGLE SINKS**

**LI 33.33.18/b-C**

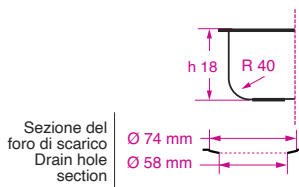
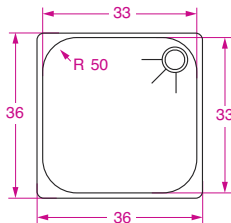

Finitura satinata  
Bordo da sottopiano tipo **C**  
  
Satin finish  
Under surface flange **C**

LI 33.33.18/b-C

Peso / Weight 2 Kg

cod. 01.06.50210

**LI 33.33.18-C20**

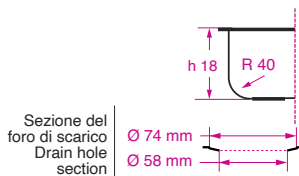
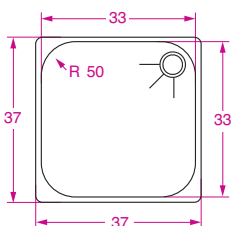

Finitura lucida  
Bordo da sottopiano tipo **C**  
  
Mirror finish  
Under surface flange **C**

LI 33.33.18-C20

Peso / Weight 1,6 Kg

cod. 01.06.50209

**LI 33.33.25**

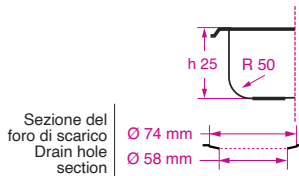
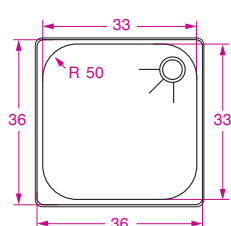

Finitura lucida  
Bordo da incasso tipo **A**  
  
Mirror finish  
Inset flange **A**

LI 33.33.25

Peso / Weight 2,2 Kg

cod. 01.06.70003

**LI 35.29.20/R/P**

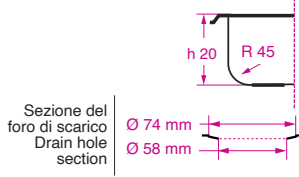
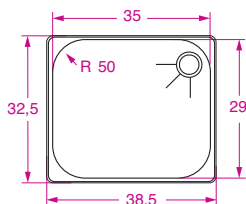

Finitura lucida  
Bordo da incasso tipo **A**  
  
Mirror finish  
Inset flange **A**

LI 35.29.20/R/P

Peso / Weight 2,1 Kg

cod. 01.13.60005

**LI 35.29.20/L/P**

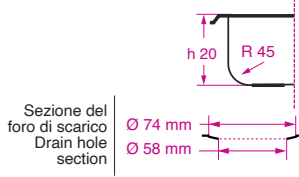
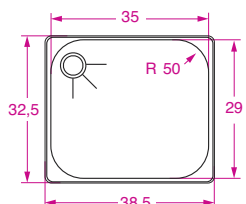

Finitura lucida  
Bordo da incasso tipo **A**  
  
Mirror finish  
Inset flange **A**

LI 35.29.20/L/P

Peso / Weight 2,1 Kg

cod. 01.13.60004

Tutte le misure sono espresse in centimetri tranne i raggi che sono espressi in millimetri  
All measurements are in centimeters, except for radius which is in millimeters





C

**LI 35.29.20-C/L**

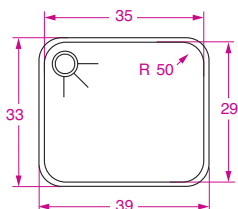

Sezione del foro di scarico  
Drain hole section

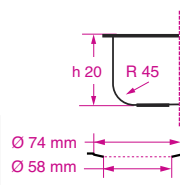

Finitura satinata  
Bordo da sottopiano tipo C

Satin finish  
Under surface flange C

LI 35.29.20-C/L

Peso / Weight 2,1 Kg

cod. 01.13.60211

**LI 40.34.20-C/L**

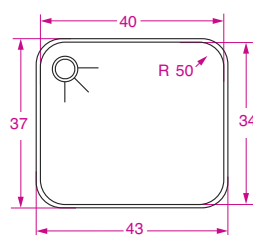

Sezione del foro di scarico  
Drain hole section

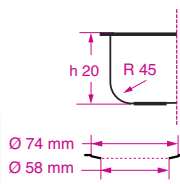

Finitura satinata  
Bordo da sottopiano tipo C

Satin finish  
Under surface flange C

LI 40.34.20-C/L

Peso / Weight 2,5 Kg

cod. 01.10.60201



**LI 30.15.15-C/T/WD**

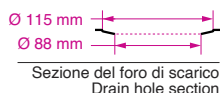
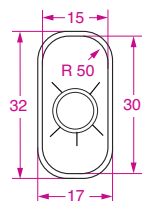

Sezione del foro di scarico  
Drain hole section

Finitura satinata  
Bordo da sottopiano tipo C  
Foro 3"1/2 - Tritarifiuti

Satin finish  
Under surface flange C  
Hole 3"1/2 - Waste Drain

LI 30.15.15-C/T/WD

Peso / Weight 675 g

cod. 01.00.22200

**LI 40.45.20-C/T/WD**

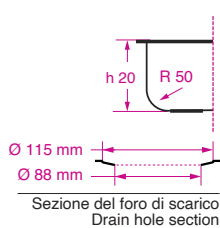
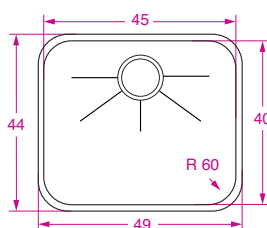

Sezione del foro di scarico  
Drain hole section

Finitura satinata  
Bordo da sottopiano tipo C  
Foro 3"1/2 - Tritarifiuti

Satin finish  
Under surface flange C  
Hole 3"1/2 - Waste Drain

LI 40.45.20-C/T/WD

Peso / Weight 2,2 Kg

cod. 01.14.62210

Tutte le misure sono espresse in centimetri tranne i raggi che sono espressi in millimetri  
All measurements are in centimeters, except for radius which is in millimeters

## LEGENDA / LEGEND

FORMA DEL BORDO / FLANGE PROFILE

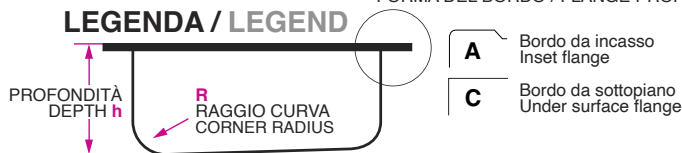

## LAVELLI DOPPI / DOUBLE SINKS

### LV 30.33.15.15-S/P

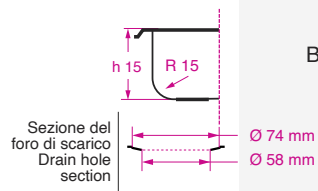
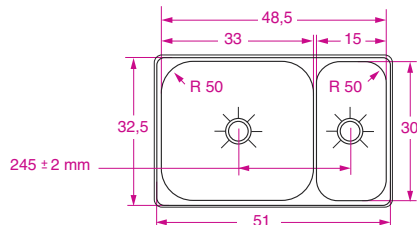

Finitura lucida  
Bordo da incasso tipo A  
Mirror finish  
Inset flange A

LV 30.33.15.15-P

Peso / Weight 2,8 Kg

cod. 01.24.20212

### LV 30.33.15.15-CS/P > SOTTOPIANO / UNDER SURFACE > FINITURA LUCIDA / MIRROR FINISH

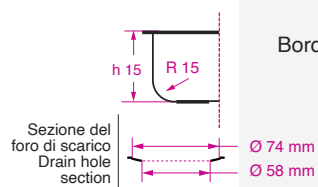
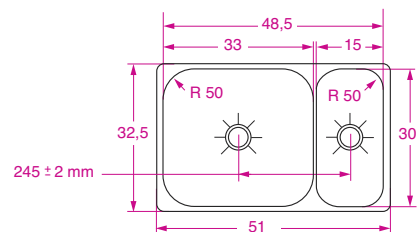

Finitura lucida  
Bordo da sottopiano tipo C  
Mirror finish  
Under surface  
flange C

LV 30.33.15.15-CS/P

Peso / Weight 2,8 Kg

cod. 01.24.20213

### LV 30.33.15.15-C

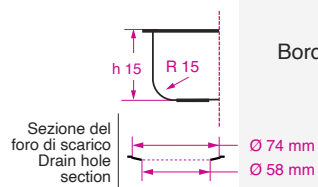
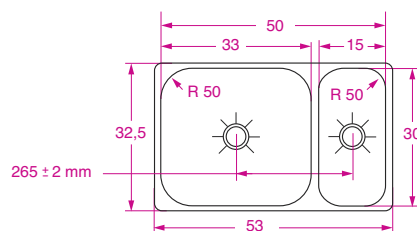

Finitura satinata  
Bordo da sottopiano tipo C  
Satin finish  
Under surface  
flange C

LV 30.33.15.15-C

Peso / Weight 2,8 Kg

cod. 01.24.20210

### LV 30.33.15.15-CS

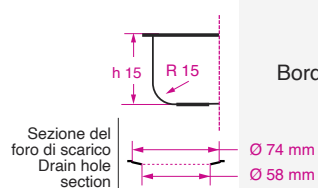
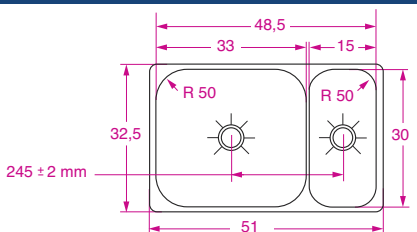

Finitura satinata  
Bordo da sottopiano tipo C  
Satin finish  
Under surface  
flange C

LV 30.33.15.15-CS

Peso / Weight 2,8 Kg

cod. 01.24.20211

Il totale drenaggio dell'acqua è sempre garantito da fori di scarico ribassati ovvero dall'inclinazione del fondo verso lo scarico.

The total water drainage is always guaranteed by the lowered drain holes or by tilting the bottom towards the drain.



Tutte le misure sono espresse in centimetri tranne i raggi che sono espressi in millimetri  
All measurements are in centimeters, except for radius which is in millimeters



I materiale, acciaio inox 18/10 di 0,8 mm di spessore, è garanzia di solidità e durata nel tempo.  
 Made in stainless steel 18/10, 0.8 mm thick for a sturdy and long-lasting product.

**LV 30.33.24.20-C/P**

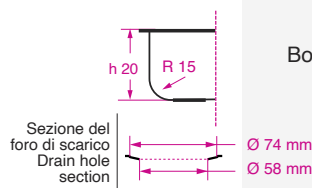
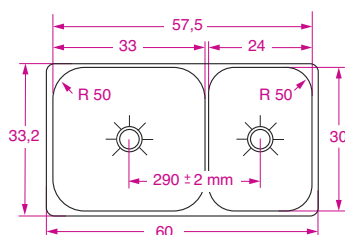

Finitura lucida  
 Bordo da sottopiano tipo C

Mirror finish  
 Under surface  
 flange C

LV 30.33.24.20-C/P

Peso / Weight 3,6 Kg

cod. 01.25.60012

**LV 30.33.24.15/P - LV 30.33.24.20/P**

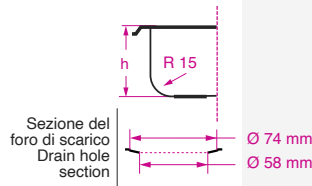
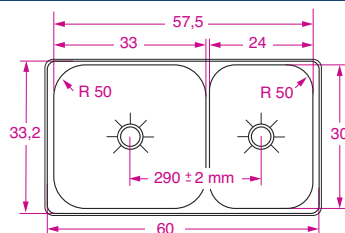

Finitura lucida  
 Bordo da incasso tipo A

Mirror finish  
 Inset flange A

LV 30.33.24.15/P h 15

Peso / Weight 2,9 Kg

cod. 01.25.20011

LV 30.33.24.20/P h 20

Peso / Weight 3,8 Kg

cod. 01.25.60011

**LV 30.33.24.15-C - LV 30.33.24.20-C**

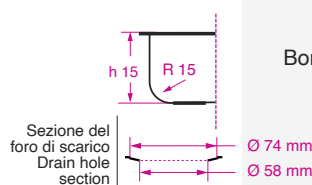
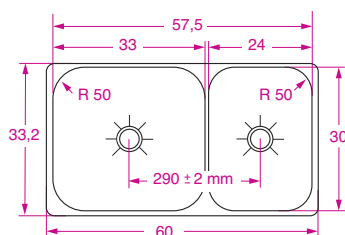

Finitura satinata  
 Bordo da sottopiano tipo C

Satin finish  
 Under surface  
 flange C

LV 30.33.24.15-C h 15

Peso / Weight 3 Kg

cod. 01.25.20010

LV 30.33.24.20-C h 20

Peso / Weight 4 Kg

cod. 01.25.60010

**LV 32.30.30.15 - LV 32.30.30.20**

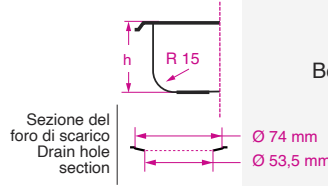
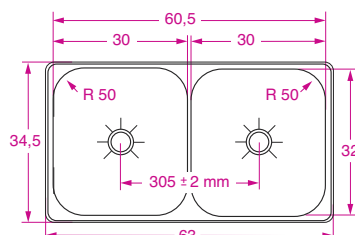

Finitura lucida  
 Bordo da incasso tipo A

Mirror finish  
 Inset flange A

LV 32.30.30.15 h 15

Peso / Weight 3,3 Kg

cod. 01.26.20003

LV 32.30.30.20 h 20

Peso / Weight 3,9 Kg

cod. 01.26.60003

Tutte le misure sono espresse in centimetri tranne i raggi che sono espressi in millimetri  
 All measurements are in centimeters, except for radius which is in millimeters

**LEGENDA / LEGEND**

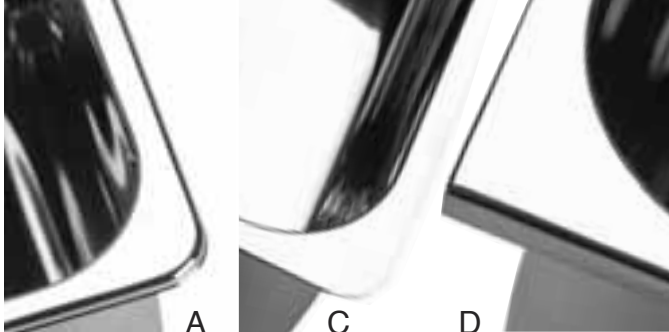
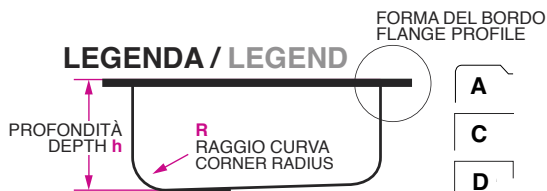

**LAVELLI DOPPI / DOUBLE SINKS**

**LV 33.33.23.16/L – LV 33.33.23.20/L**

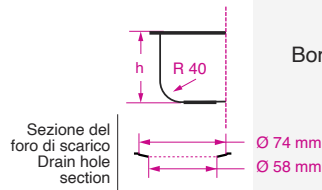
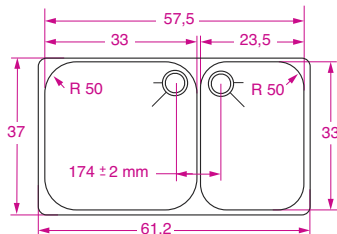

Finitura lucida  
Bordo da sottopiano tipo C

Mirror finish  
Under surface  
flange C

LV 33.33.23.16/L h 16

Peso / Weight 3,2 Kg

cod. 01.30.30201

LV 33.33.23.20/L h 20

Peso / Weight 3,7 Kg

cod. 01.31.60201

**LV 33.33.23.16/b-L – LV 33.33.23.20/b-L**

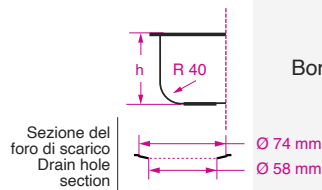
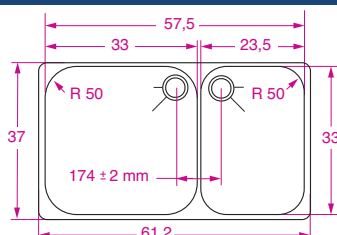

Finitura satinata  
Bordo da sottopiano tipo C

Satin finish  
Under surface  
flange C

LV 33.33.23.16/b-L h 16

Peso / Weight 3,2 Kg

cod. 01.30.30211

LV 33.33.23.20/b-L h 20

Peso / Weight 3,7 Kg

cod. 01.31.60211

**LV 33.33.23.16/R – LV 33.33.23.20/R**

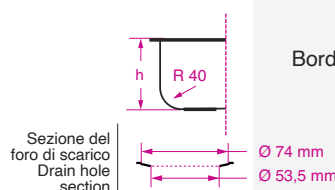
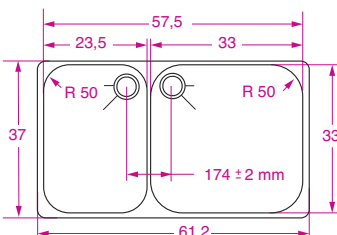

Finitura lucida  
Bordo da sottopiano tipo C

Mirror finish  
Under surface  
flange C

LV 33.33.23.16/R h 16

Peso / Weight 3,2 Kg

cod. 01.30.30202

LV 33.33.23.20/R h 20

Peso / Weight 3,7 Kg

cod. 01.31.60202

**LV 33.33.23.16/b-R – LV 33.33.23.20/b-R**

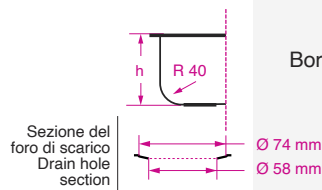
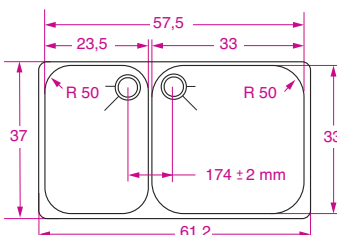

Finitura satinata  
Bordo da sottopiano tipo C

Satin finish  
Under surface  
flange C

LV 33.33.23.16/b-R h 16

Peso / Weight 3,2 Kg

cod. 01.30.30212

LV 33.33.23.20/b-R h 20

Peso / Weight 3,7 Kg

cod. 01.31.60212

**LV 33.33.23.16/R-D**

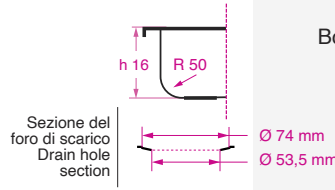
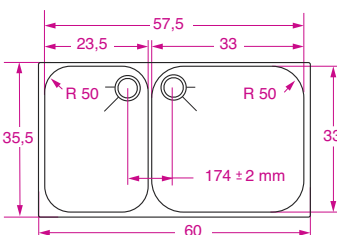

Finitura lucida  
Bordo da incasso tipo D  
Con dadi di fissaggio

Mirror finish  
Inset flange D  
With fixing nuts

LV 33.33.23.16/R-D

Peso / Weight 3,2 Kg

cod. 01.30.30302

Tutte le misure sono espresse in centimetri tranne i raggi che sono espressi in millimetri  
All measurements are in centimeters, except for radius which is in millimeters



**LV 35.29.29.20-C/P**

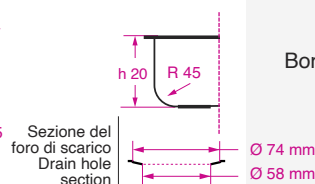
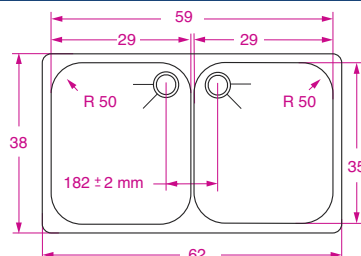

Finitura lucida  
Bordo da sottopiano tipo C

Mirror finish  
Under surface  
flange C

LV 35.29.29.20-C/P

Peso / Weight 3,9 Kg

cod. 01.36.60311

**LV 35.29.29.20-C**

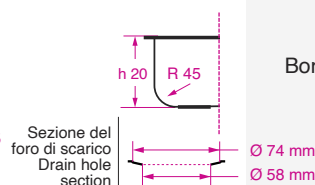
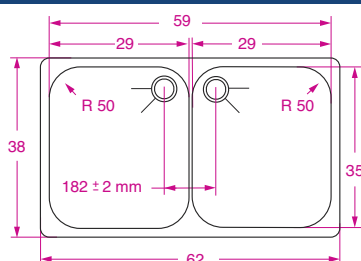

Finitura satinata  
Bordo da sottopiano tipo C

Satin finish  
Under surface  
flange C

LV 35.29.29.20-C

Peso / Weight 4 Kg

cod. 01.36.60310

**LV 33.33.33.20-C**

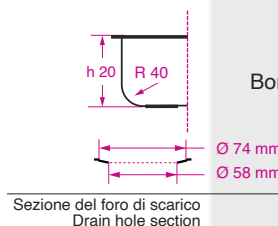
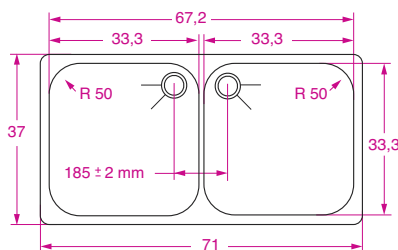

Finitura lucida  
Bordo da sottopiano tipo C

Mirror finish  
Under surface  
flange C

LV 33.33.33.20-C

Peso / Weight 4 Kg

cod. 01.32.60200

**LV 33.33.33.20/b-C**

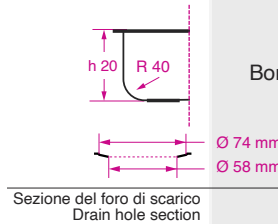
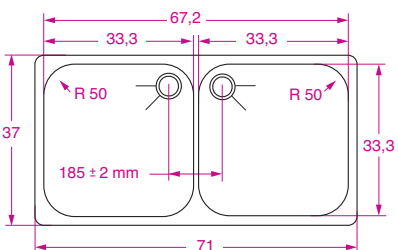

Finitura satinata  
Bordo da sottopiano tipo C

Satin finish  
Under surface  
flange C

LV 33.33.33.20/b-C

Peso / Weight 4,3 Kg

cod. 01.32.60210

**LV 29.34.34.20**

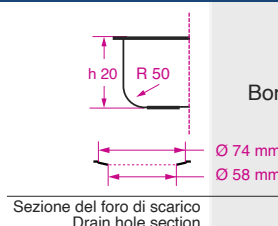
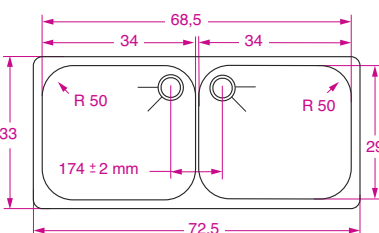

Finitura lucida  
Bordo da sottopiano tipo C

Mirror finish  
Under surface  
flange C

LV 29.34.34.20

Peso / Weight 4 Kg

cod. 01.34.60300

Tutte le misure sono espresse in centimetri tranne i raggi che sono espressi in millimetri  
All measurements are in centimeters, except for radius which is in millimeters

**LEGENDA / LEGEND**

FORMA DEL BORDO / FLANGE PROFILE



C



**LAVELLI SINGOLI SQUADRATI / SINGLE TIGHT CORNERS SINKS**

**LI 40.18.14-C/15T/WD**

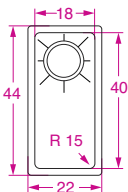

Sezione del foro di scarico  
Drain hole section

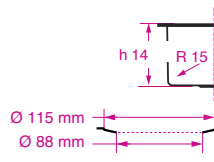

Peso / Weight 1,6 Kg

Finitura semi-lucida  
Forma squadrata  
Bordo da sottopiano tipo C  
Foro 3"1/2 - Tritarifiuti

Semi-gloss finish  
Tight corners – Flat flange C  
Hole 3"1/2 - Waste Drain

**cod. 01.09.22210**

LI 40.18.14-C/15T/WD

**LI 40.27.20-C/15T/WD**

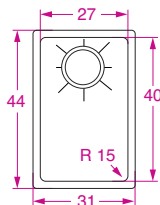

Sezione del foro di scarico  
Drain hole section

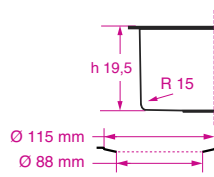

Peso / Weight 2,4 Kg

Finitura semi-lucida  
Forma squadrata  
Bordo da sottopiano tipo C  
Foro 3"1/2 - tritarifiuti

Semi-gloss finish  
Tight corners – Flat flange C  
Hole 3"1/2 - Waste Drain

**cod. 01.09.62210**

LI 40.27.20-C/15T/WD

**LI 40.34.20-C/15T/WD**

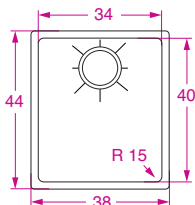

Sezione del foro di scarico  
Drain hole section

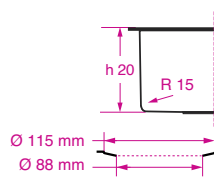

Peso / Weight 2,9 Kg

Finitura semi-lucida  
Forma squadrata  
Bordo da sottopiano tipo C  
Foro 3"1/2 - Tritarifiuti

Semi-gloss finish  
Tight corners – Flat flange C  
Hole 3"1/2 - Waste Drain

**cod. 01.10.62210**

LI 40.34.20-C/15T/WD

**LI 40.40.20-C/15T/WD**

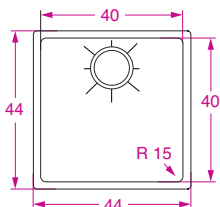

Sezione del foro di scarico  
Drain hole section

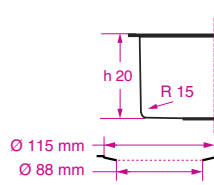

Peso / Weight 3,3 Kg

Finitura semi-lucida  
Forma squadrata  
Bordo da sottopiano tipo C  
Foro 3"1/2 - Tritarifiuti

Semi-gloss finish  
Tight corners – Flat flange C  
Hole 3"1/2 - Waste Drain

**cod. 01.11.62210**

LI 40.40.20-C/15T/WD

**LI 40.45.20-C/15T/WD**

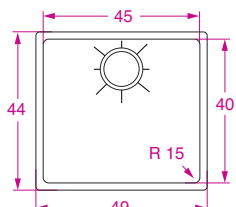

Sezione del foro di scarico  
Drain hole section

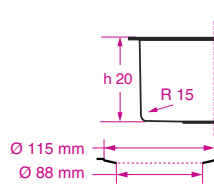

Peso / Weight 3,5 Kg

Finitura semi-lucida  
Forma squadrata  
Bordo da sottopiano tipo C  
Foro 3"1/2 - Tritarifiuti

Semi-gloss finish  
Tight corners – Flat flange C  
Hole 3"1/2 - Waste Drain

**cod. 01.11.72210**

LI 40.45.20-C/15T/WD

**LI 40.50.20-C/15T/WD**

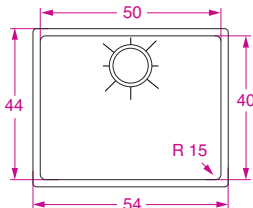

Sezione del foro di scarico  
Drain hole section

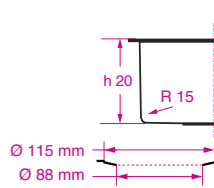

Peso / Weight 3,8 Kg

Finitura semi-lucida  
Forma squadrata  
Bordo da sottopiano tipo C  
Foro 3"1/2 - Tritarifiuti

Semi-gloss finish  
Tight corners – Flat flange C  
Hole 3"1/2 - Waste Drain

**cod. 01.12.62210**

LI 40.50.20-C/15T/WD

Tutte le misure sono espresse in centimetri tranne i raggi che sono espressi in millimetri  
All measurements are in centimeters, except for radius which is in millimeters

Piletta di scarico non inclusa / Waste drain not included

LEGENDA / LEGEND

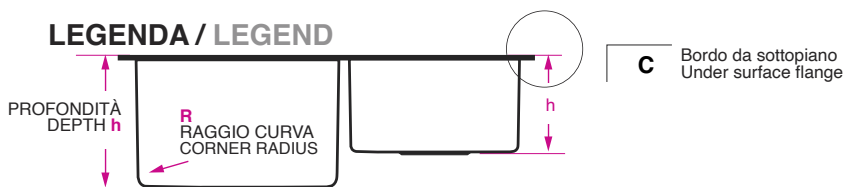

LAVELLI DOPPI SQUADRATI / DOUBLE TIGHT CORNERS SINKS

LV 40.27.18.20-C/15T/WD

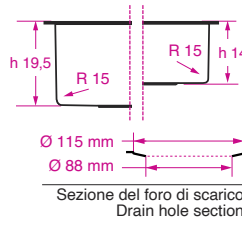
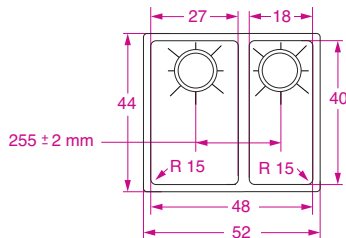

Finitura semi-lucida  
 Forma squadrata  
 Bordo da sottopiano tipo C  
 Foro 3"1/2 - Tritarifiuti

Semi-gloss finish  
 Tight corners – Flat flange C  
 Hole 3"1/2 - Waste Drain

LV 40.27.18.20-C/15T/WD

Peso / Weight 4,1 Kg

cod. 01.20.00005

LV 40.27.27.20-C/15T/WD

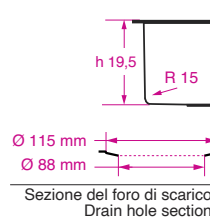
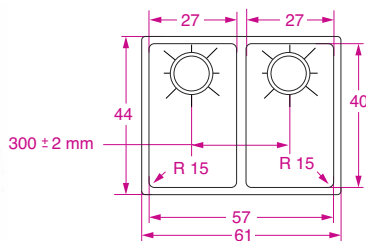

Finitura semi-lucida  
 Forma squadrata  
 Bordo da sottopiano tipo C  
 Foro 3"1/2 - Tritarifiuti

Semi-gloss finish  
 Tight corners – Flat flange C  
 Hole 3"1/2 - Waste Drain

LV 40.27.27.20-C/15T/WD

Peso / Weight 4,9 Kg

cod. 01.20.00007

LV 40.34.18.20-C/15T/WD

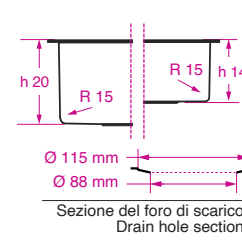
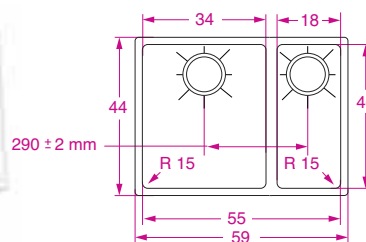

Finitura semi-lucida  
 Forma squadrata  
 Bordo da sottopiano tipo C  
 Foro 3"1/2 - Tritarifiuti

Semi-gloss finish  
 Tight corners – Flat flange C  
 Hole 3"1/2 - Waste Drain

LV 40.34.18.20-C/15T/WD

Peso / Weight 4,4 Kg

cod. 01.20.00010

LV 40.40.27.20-C/15T/WD > SOTTOPIANO / UNDER SURFACE

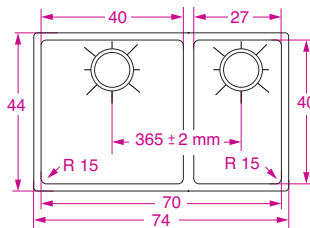

Finitura semi-lucida  
 Forma squadrata  
 Bordo da sottopiano tipo C  
 Foro 3"1/2 - Tritarifiuti

Semi-gloss finish  
 Tight corners – Flat flange C  
 Hole 3"1/2 - Waste Drain

LV 40.40.27.20-C/15T/WD

Peso / Weight 5,8 Kg

cod. 01.20.00016

LV 40.45.27.20-C/15T/WD

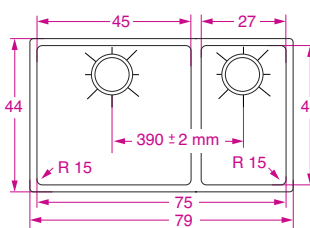

Finitura semi-lucida  
 Forma squadrata  
 Bordo da sottopiano tipo C  
 Foro 3"1/2 - Tritarifiuti

Semi-gloss finish  
 Tight corners – Flat flange C  
 Hole 3"1/2 - Waste Drain

LV 40.45.27.20-C/15T/WD

Peso / Weight 6,2 Kg

cod. 01.20.00024

Piletta di scarico non inclusa / Waste drain not included

Tutte le misure sono espresse in centimetri tranne i raggi che sono espresse in millimetri  
 All measurements are in centimeters, except for radius which is in millimeters



LV 40.34.34.20-C/15T/WD



LV 40.34.34.20-C/15T/WD

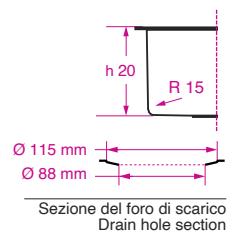
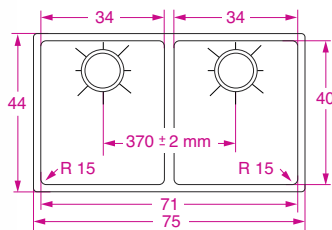

Peso / Weight 5,6 Kg

Finitura semi-lucida  
Forma squadrata  
Bordo da sottopiano tipo C  
Foro 3"1/2 - Tritarifiuti

Semi-gloss finish  
Tight corners – Flat flange C  
Hole 3"1/2 - Waste Drain

cod. 01.20.00013

LV 40.40.34.20-C/15T/WD



LV 40.40.34.20-C/15T/WD

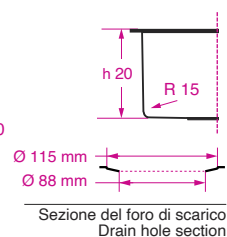
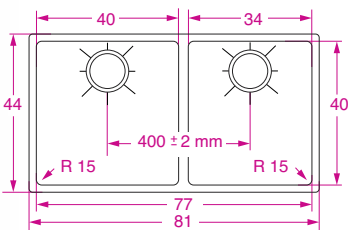

Peso / Weight 6,1 Kg

Finitura semi-lucida  
Forma squadrata  
Bordo da sottopiano tipo C  
Foro 3"1/2 - Tritarifiuti

Semi-gloss finish  
Tight corners – Flat flange C  
Hole 3"1/2 - Waste Drain

cod. 01.20.00019

Tutte le misure sono espresse in centimetri tranne i raggi che sono espressi in millimetri  
All measurements are in centimeters, except for radius which is in millimeters

Piletta di scarico non inclusa / Waste drain not included

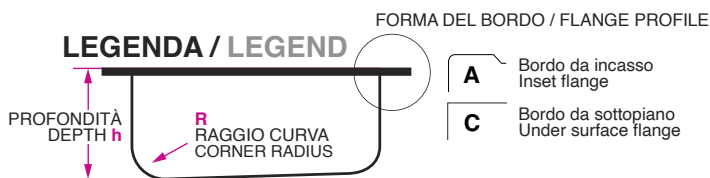

## LAVELLI CILINDRICI / CYLINDRICAL SINKS

### LI CIL 26/SD

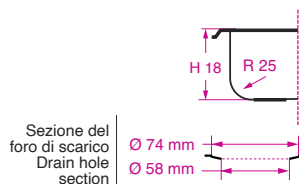
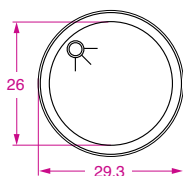

Finitura lucida  
Bordo da incasso tipo **A**

Mirror finish  
Inset flange **A**

LI CIL 26/SD

Peso / Weight 1,1 Kg

cod. 01.62.50000

### LI CIL 26/5sb

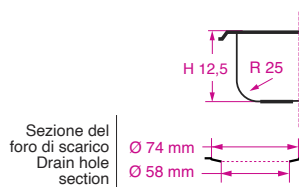
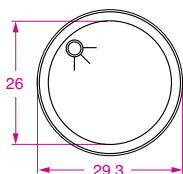

Finitura satinata  
Bordo da incasso tipo **A**

Satin finish  
Inset flange **A**

LI CIL 26/5sb

Peso / Weight 860 g

cod. 01.62.10040

### LI CIL 30/C

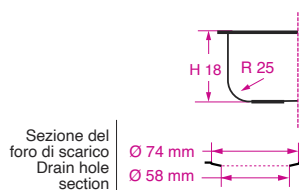
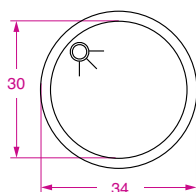

Finitura lucida  
Bordo da sottopiano tipo **C**

Mirror finish  
Flat flange **C**

LI CIL 30/C

Peso / Weight 1,3 Kg

cod. 01.63.50300

### LI CIL 30/SD > INCASSO / INSET > FINITURA LUCIDA / MIRROR FINISH

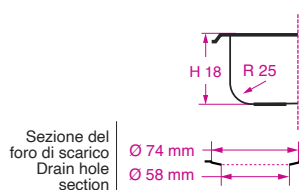
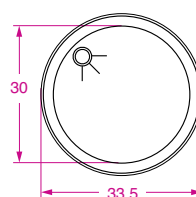

Finitura lucida  
Bordo da incasso tipo **A**

Mirror finish  
Inset flange **A**

LI CIL 30/SD

Peso / Weight 1,3 Kg

cod. 01.63.50000

### LI CIL 30/5 L - LI CIL 30/5 sb

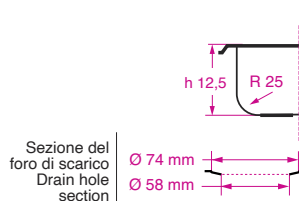
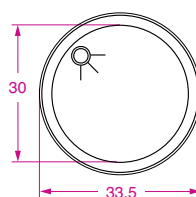

Bordo da incasso tipo **A**

Inset flange **A**

LI CIL 30/5 L

Finitura lucida / Mirror finish

cod. 01.63.10000

LI CIL 30/5 sb

Finitura satinata / Satin finish

Peso / Weight 1,1 Kg

cod. 01.63.10040

Tutte le misure sono espresse in centimetri tranne i raggi che sono espressi in millimetri  
All measurements are in centimeters, except for radius which is in millimeters



**LEGENDA / LEGEND**

FORMA DEL BORDO / FLANGE PROFILE

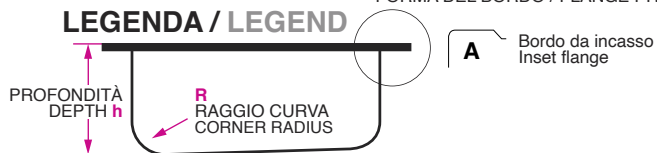

**LAVELLI CILINDRICI / CYLINDRICAL SINKS A**

**LI CIL 36**

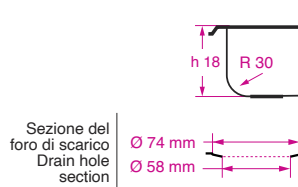
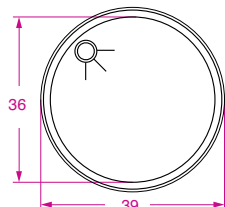

Finitura lucida  
Bordo da incasso tipo A  
  
Mirror finish  
Inset flange A

LI CIL 36

Peso / Weight 1,9 Kg

cod. 01.65.50000

**LI CIL 41**

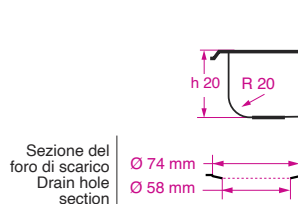
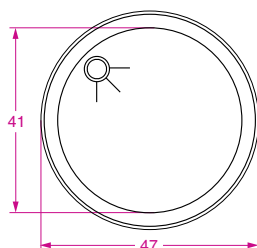

Finitura lucida  
Bordo da incasso tipo A  
  
Mirror finish  
Inset flange A

LI CIL 41

Peso / Weight 2,8 Kg

cod. 01.66.60000

**LI CIL 42**

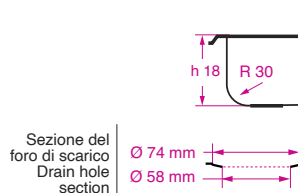
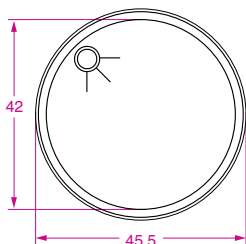

Finitura lucida  
Bordo da incasso tipo A  
  
Mirror finish  
Inset flange A

LI CIL 42

Peso / Weight 2,5 Kg

cod. 01.67.50000



Tutte le misure sono espresse in centimetri tranne i raggi che sono espressi in millimetri  
All measurements are in centimeters, except for radius which is in millimeters

## LAVABI / BASINS

### LI SS 20 – LISS 20/5 sb

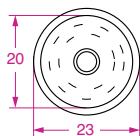

Sezione del  
foro di scarico  
Drain hole  
section

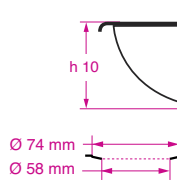

Bordo da incasso tipo A  
Inset flange A

LI SS 20

Finitura lucida / Mirror finish

cod. 01.70.00000

LI SS 20/5 sb

Finitura satinata / Satin finish

Peso / Weight 400 g

cod. 01.70.00040

### LI SS 26 – LISS 26/5 sb

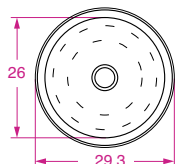

Sezione del  
foro di scarico  
Drain hole  
section

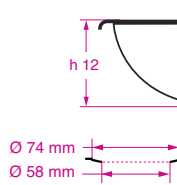

Bordo da incasso tipo A  
Inset flange A

LI SS 26

Finitura lucida / Mirror finish

cod. 01.72.10000

LI SS 26/5 sb

Finitura satinata / Satin finish

Peso / Weight 600 g

cod. 01.72.10040

### LI SS 30/SD

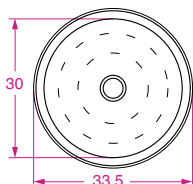

Sezione del  
foro di scarico  
Drain hole  
section

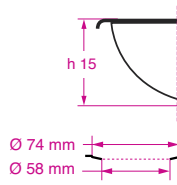

Finitura lucida  
Bordo da incasso tipo A  
Mirror finish  
Inset flange A

LI SS 30/SD

Peso / Weight 780 g

cod. 01.73.20000

### LI SS 36

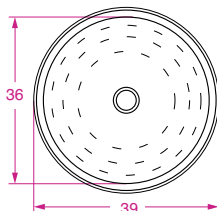

Sezione del  
foro di scarico  
Drain hole  
section

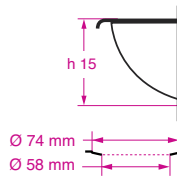

Finitura lucida  
Bordo da incasso tipo A  
Mirror finish  
Inset flange A

LI SS 36

Peso / Weight 1,1 Kg

cod. 01.75.50000

### LI GO 34

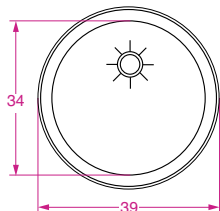

Sezione del  
foro di scarico  
Drain hole  
section

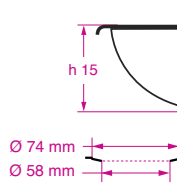

Finitura lucida  
Bordo da incasso tipo A  
Mirror finish  
Inset flange A

LI GO 34

Peso / Weight 1,4 Kg

cod. 01.80.50000



Vista laterale  
Side view  
LIGO 34

Tutte le misure sono espresse in centimetri tranne i raggi che sono espressi in millimetri  
All measurements are in centimeters, except for radius which is in millimeters

**LEGENDA / LEGEND**

FORMA DEL BORDO / FLANGE PROFILE

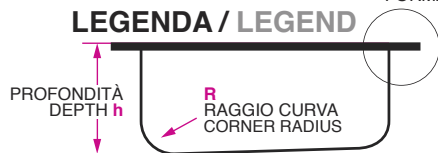

**A** Bordo da incasso  
Inset flange



**LAVABI / BASINS**

**LI OVAL 35**

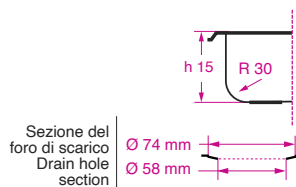
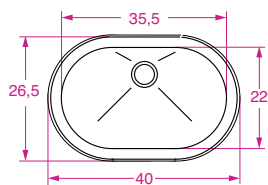

Finitura lucida  
Bordo da incasso tipo **A**  
  
Mirror finish  
Inset flange **A**

**LI OVAL 35**

Peso / Weight 1,4 Kg

**cod. 01.80.10003**

**LI OVAL 36**

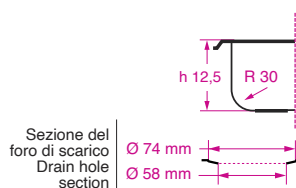
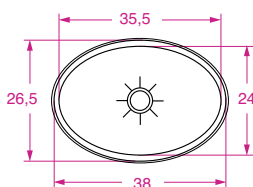

Finitura lucida  
Bordo da incasso tipo **A**  
  
Mirror finish  
Inset flange **A**

**LI OVAL 36**

Peso / Weight 1,2 Kg

**cod. 01.80.20000**

**LI OVAL 38/1**

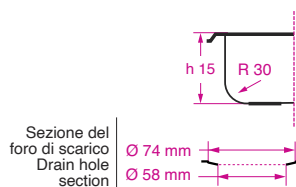
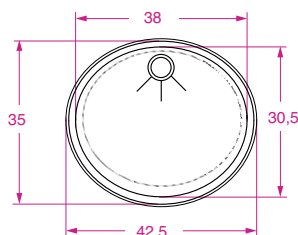

Finitura lucida  
Bordo da incasso tipo **A**  
  
Mirror finish  
Inset flange **A**

**LI OVAL 38/1**

Peso / Weight 1,6 Kg

**cod. 01.80.30003**

**LI OVAL 45**

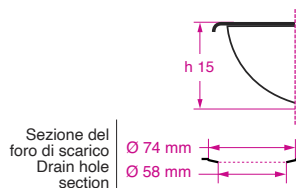
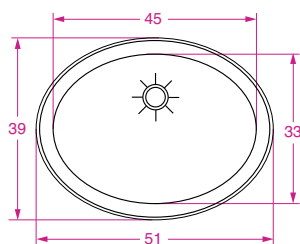

Finitura lucida  
Bordo da incasso tipo **A**  
  
Mirror finish  
Inset flange **A**

**LI OVAL 45**

Peso / Weight 1,6 Kg

**cod. 01.80.40000**

**LI OVAL 45/L**

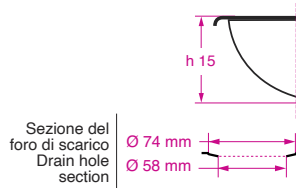
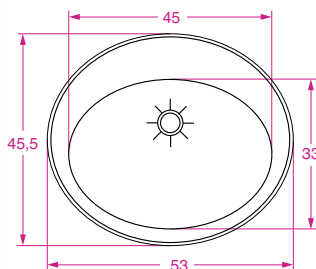

Finitura lucida  
Bordo da incasso tipo **A**  
  
Mirror finish  
Inset flange **A**

**LI OVAL 45/L**

Peso / Weight 2,3 Kg

**cod. 01.80.40600**

Tutte le misure sono espresse in centimetri tranne i raggi che sono espressi in millimetri  
All measurements are in centimeters, except for radius which is in millimeters





## PILETTE DI SCARICO SINGOLE / SINGLE WASTE DRAINERS

### PI 1435 TM > SINGOLA / SINGLE > FILETTO DA 1"1/4 M GAS / TREAD 1"1/4 M BSP

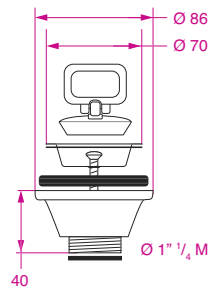

Adatta a foro Ø  
min. 53,5 mm → max 58 mm.  
Con tappo a maniglia.  
Corpo bianco.

Suitable for hole  
min. 53,5 mm → max 58 mm.  
Plug with handle.  
White body.

PI 1435 TM

Peso / Weight 87 g

cod. 02.01.10001

### PI 1235 > SINGOLA / SINGLE > FILETTO DA 1"1/2 M GAS / TREAD 1"1/2 M BSP

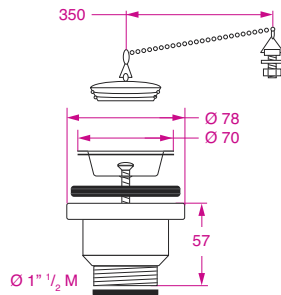

Adatta a foro Ø  
min. 53,5 mm → max 58 mm.  
Con tappo a catenella.  
Corpo grigio metallizzato.

Suitable for hole  
min. 53,5 mm → max 58 mm.  
Plug with chain.  
Silver grey body.

PI 1235

Peso / Weight 149 g

cod. 02.01.20000

### PI 1235 GR > SINGOLA / SINGLE > FILETTO DA 1"1/2 M GAS / TREAD 1"1/2 M BSP

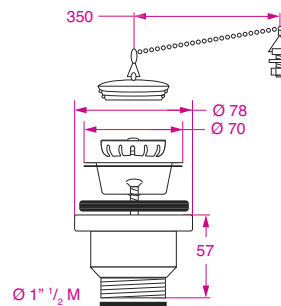

Adatta a foro Ø  
min. 53,5 mm → max 58 mm.  
Con griglia estraibile  
e tappo a catenella.  
Corpo grigio metallizzato.

Suitable for hole  
min. 53,5 mm → max 58 mm.  
With removable grid and  
plug with chain.  
Silver grey body.

PI 1235 GR

Peso / Weight 173 g

cod. 02.01.20010

### PF 2535 > SINGOLA / SINGLE > A GOMITO Ø 25 MM (1") / ELBOW CONNECTION DIA 25 MM (1")

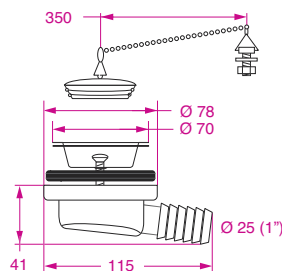

Adatta a foro Ø  
min. 53,5 mm → max 58 mm.  
Con tappo a catenella.  
Corpo grigio metallizzato.

Suitable for hole  
min. 53,5 mm → max 58 mm.  
Plug with chain.  
Silver grey body.

PF 2535

Peso / Weight 140 g

cod. 02.01.40000

### PF 2535 TM > SINGOLA / SINGLE > A GOMITO Ø 25 MM (1") / ELBOW CONNECTION DIA 25 MM (1")

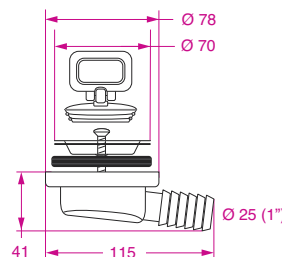

Adatta a foro Ø  
min. 53,5 mm → max 58 mm.  
Con tappo a maniglia.  
Corpo grigio metallizzato.

Suitable for hole  
min. 53,5 mm → max 58 mm.  
Plug with chain.  
Silver grey body.

PF 2535 TM

Peso / Weight 120 g

cod. 02.01.40002

Misure in millimetri / Measurements in millimeters

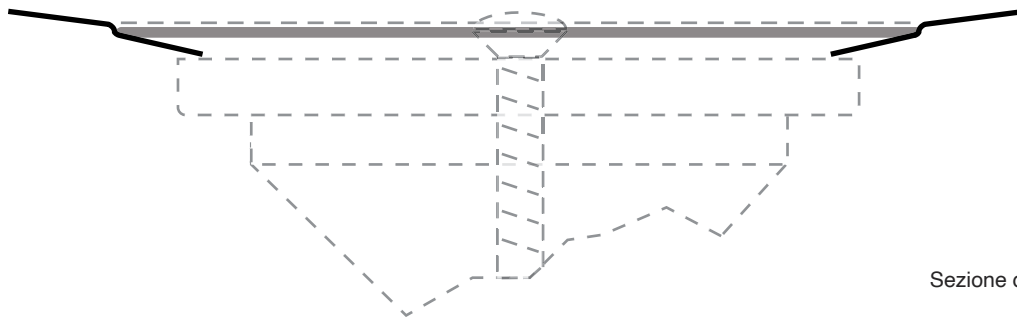

Sezione del foro sul lavello  
Sink hole section

**PF 2535 GR > SINGOLA / SINGLE > A GOMITO Ø 25 MM (1") / ELBOW CONNECTION DIA 25 MM (1")**

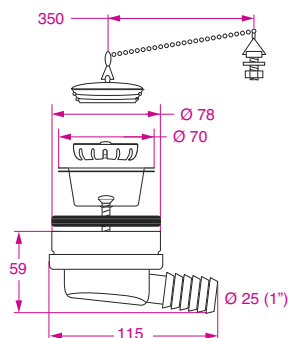

Adatta a foro Ø  
min. 53,5 mm → max 58 mm.  
Con griglia estraibile  
e tappo a catenella.  
Corpo grigio metallizzato.

Suitable for hole  
min. 53,5 mm → max 58 mm.  
Plug with chain.  
Silver grey body.

PF 2535 GR

Peso / Weight 170 g

cod. 02.01.40010

**PI 120 S > SINGOLA / SINGLE > FILETTO DA 1"1/2 M GAS / TREAD 1"1/2 M BSP**

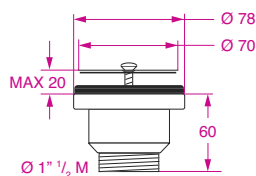

Adatta a foro Ø  
min. 53,5 mm → max 58 mm.  
Salvaspazio. Per piatti doccia.  
Con griglia piana.  
Corpo grigio metallizzato.

Suitable for hole  
min. 53,5 mm → max 58 mm.  
Space-saving type. For  
shower trays. With flat grid.  
Silver grey body.

PI 120 S

Peso / Weight 91 g

cod. 02.01.20025

**PF 250 S > SINGOLA / SINGLE > A GOMITO Ø 25 MM (1") / ELBOW CONNECTION DIA 25 MM (1")**

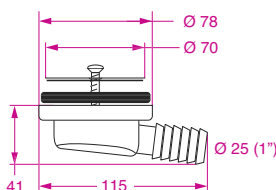

Adatta a foro Ø  
min. 53,5 mm → max 58 mm.  
Salvaspazio. Per piatti doccia.  
Con griglia piana.  
Corpo grigio metallizzato.

Suitable for hole  
min. 53,5 mm → max 58 mm.  
Space-saving type. For  
shower trays. With flat grid.  
Silver grey body.

PF 250 S

Peso / Weight 81 g

cod. 02.01.40020

**PF 400 S > SINGOLA / SINGLE > SCARICO A 90° - Ø 40 MM / ELBOW WASTE DRAINER 90° - DIA 40 MM**

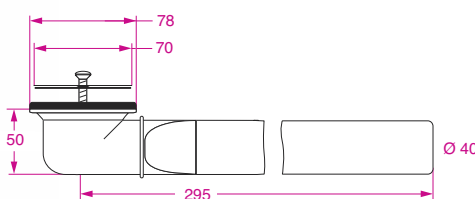

Adatta a foro Ø  
min. 53,5 mm → max 58 mm.  
Salvaspazio. Per scarico  
pozzetti. Con griglia piana.  
Corpo grigio metallizzato.

Suitable for hole  
min. 53,5 mm → max 58 mm.  
Space-saving type.  
For cockpits. With flat grid.  
Silver grey body.

PF 400 S

Peso / Weight 160 g

cod. 02.01.40040

Tutte le pilette elencate, sono adatte ai nostri fori STANDARD, salvo diversamente indicato  
All drainers are suited for our STANDARD holes, unless otherwise specified

# PILETTE DI SCARICO DOPPIE / DOUBLE WASTE DRAINERS

**PD 1235 gr/L > DOPPIA / DOUBLE > KIT PER TUBI Ø 40 MM / KIT FOR HOSES DIA 40 MM**



PD 1235 GR/L

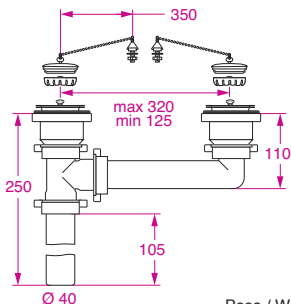

Peso / Weight 523 g

Adatta a fori Ø min. 53,5 mm → max 58 mm.  
Con griglia estraibile e tappo a catenella.  
Corpo grigio metallizzato.

Suitable for holes min. 53,5 mm → max 58 mm.  
Plug with chain.  
Silver grey body.

**cod. 02.01.22011**

**PD 1235/L > DOPPIA / DOUBLE > KIT PER TUBI Ø 40 MM / KIT FOR HOSES DIA 40 MM**



PD 1235/L

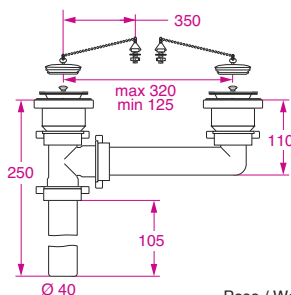

Peso / Weight 475 g

Adatta a fori Ø min. 53,5 mm → max 58 mm.  
Con tappo a catenella.  
Corpo grigio metallizzato.

Suitable for holes min. 53,5 mm → max 58 mm.  
Plug with chain.  
Silver grey body.

**cod. 02.01.22001**

**PD 1235/32 > DOPPIA / DOUBLE > KIT PER TUBI Ø 32 MM / KIT FOR HOSES DIA 32 MM**



PD 1235/32

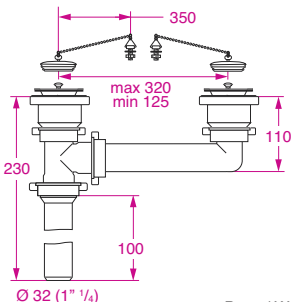

Peso / Weight 469 g

Adatta a fori Ø min. 53,5 mm → max 58 mm.  
Con tappo a catenella.  
Corpo grigio metallizzato.

Suitable for holes min. 53,5 mm → max 58 mm.  
Plug with chain.  
Silver grey body.

**cod. 02.01.22004**

**PD 1235/25 > DOPPIA / DOUBLE > KIT PER TUBI Ø 25 MM / KIT FOR HOSES DIA 25 MM**



PD 1235/25

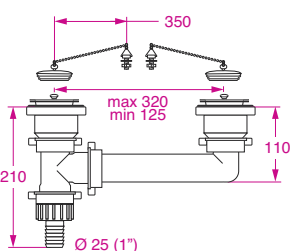

Peso / Weight 474 g

Adatta a fori Ø min. 53,5 mm → max 58 mm.  
Con tappo a catenella.  
Corpo grigio metallizzato.

Suitable for holes min. 53,5 mm → max 58 mm.  
Plug with chain.  
Silver grey body.

**cod. 02.01.22003**

**PD 1235/20 > DOPPIA / DOUBLE > KIT PER TUBI Ø 20 MM / KIT FOR HOSES DIA 20 MM**



PD 1235/20

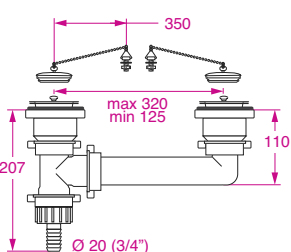

Peso / Weight 474 g

Adatta a fori Ø min. 53,5 mm → max 58 mm.  
Con tappo a catenella.  
Corpo grigio metallizzato.

Suitable for holes min. 53,5 mm → max 58 mm.  
Plug with chain.  
Silver grey body.

**cod. 02.01.22002**

Misure in millimetri / Measurements in millimeters

**P2 1435 TM > DOPPIA / DOUBLE > KIT PER TUBI Ø 32 MM / KIT FOR HOSES DIA 32 MM**



P2 1435 TM

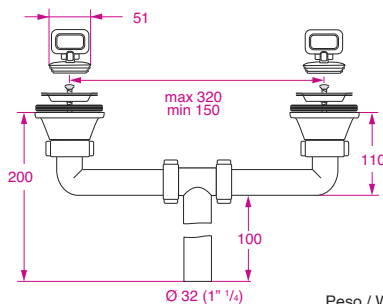

Peso / Weight 283 g

Adatta a fori Ø min. 53,5 mm → max 58 mm.  
Con tappo a maniglia.  
Corpo bianco.

Suitable for holes min. 53,5 mm → max 58 mm.  
Plug with handle.  
White body.

**cod. 02.01.12002**

**P2 1235 > DOPPIA / DOUBLE > KIT PER TUBI Ø 40 MM / KIT FOR HOSES DIA 40 MM**



P2 1235

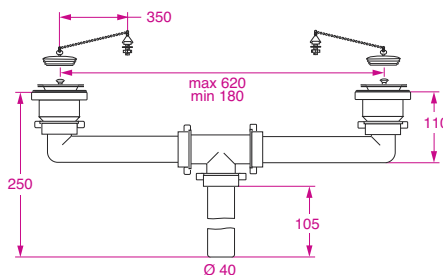

Peso / Weight 568 g

Adatta a fori Ø min. 53,5 mm → max 58 mm.  
Con tappo a catenella.  
Corpo grigio metallizzato.

Suitable for holes min. 53,5 mm → max 58 mm.  
Plug with chain.  
Silver grey body.

**cod. 02.01.23001**

**P2 1235/32 > DOPPIA / DOUBLE > KIT PER TUBI Ø 32 MM / KIT FOR HOSES DIA 32 MM**



P2 1235/32

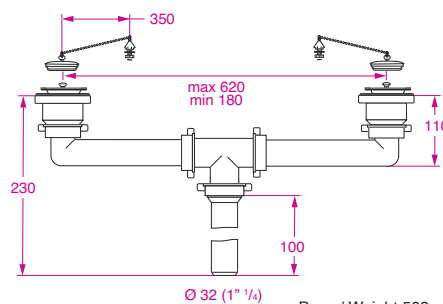

Peso / Weight 562 g

Adatta a fori Ø min. 53,5 mm → max 58 mm.  
Con tappo a catenella.  
Corpo grigio metallizzato.

Suitable for holes min. 53,5 mm → max 58 mm.  
Plug with chain.  
Silver grey body.

**cod. 02.01.23004**

**P2 1235/25 > DOPPIA / DOUBLE > KIT PER TUBI Ø 25 MM / KIT FOR HOSES DIA 25 MM**



P2 1235/25

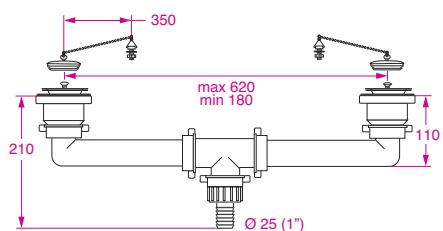

Peso / Weight 567 g

Adatta a fori Ø min. 53,5 mm → max 58 mm.  
Con tappo a catenella.  
Corpo grigio metallizzato.

Suitable for holes min. 53,5 mm → max 58 mm.  
Plug with chain.  
Silver grey body.

**cod. 02.01.23003**

**P21235/20 > DOPPIA / DOUBLE > KIT PER TUBI Ø 20 MM / KIT FOR HOSES DIA 20 MM**



P2 1235/20

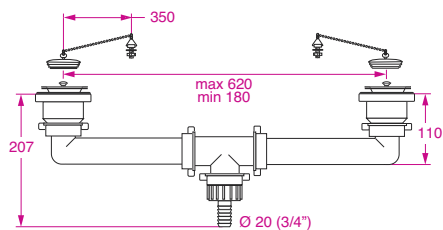

Peso / Weight 567 g

Adatta a fori Ø min. 53,5 mm → max 58 mm.  
Con tappo a catenella.  
Corpo grigio metallizzato.

Suitable for holes min. 53,5 mm → max 58 mm.  
Plug with chain.  
Silver grey body.

**cod. 02.01.23002**

Tutte le pilette elencate, sono adatte ai nostri fori STANDARD, salvo diversamente indicato  
All drainers are suited for our STANDARD holes, unless otherwise specified



## PILETTE DI SCARICO / WASTE DRAINERS

### PF 3260 GP > SINGOLA / SINGLE > A GOMITO Ø 32 MM / ELBOW CONNECTION DIA 32 MM

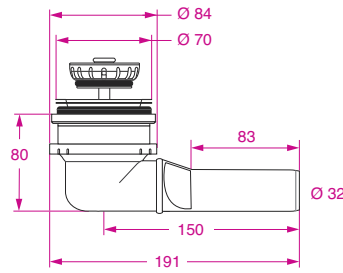

Adatta a foro Ø min. 56 mm.  
Con griglia estraibile  
con funzione di tappo.  
Corpo grigio metallizzato.

Suitable for hole min. 56 mm.  
With removable grid  
with plug function.  
Silver grey body.

PF 3260 GP

Peso / Weight 245 g

cod. 02.01.31010

### P2F 3260 GP > DOPPIA / DOUBLE > KIT PER TUBI Ø 32 MM / KIT FOR HOSES DIA 32 MM

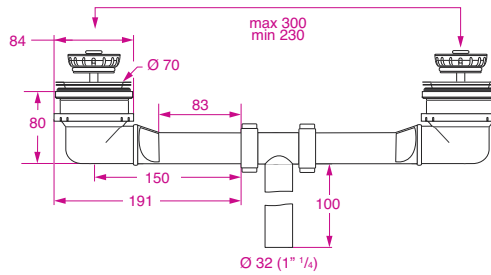

Adatta a fori Ø min. 56 mm.  
Con griglia estraibile  
con funzione di tappo.  
Corpo grigio metallizzato e  
bianco.

Suitable for holes min. 56 mm.  
With removable grid  
with plug function.  
Silver grey and white body.

P2F 3260 GP

Peso / Weight 537 g

cod. 02.01.31011

### PSV 40 > SIFONE A "TUBO" / "P" TRAP

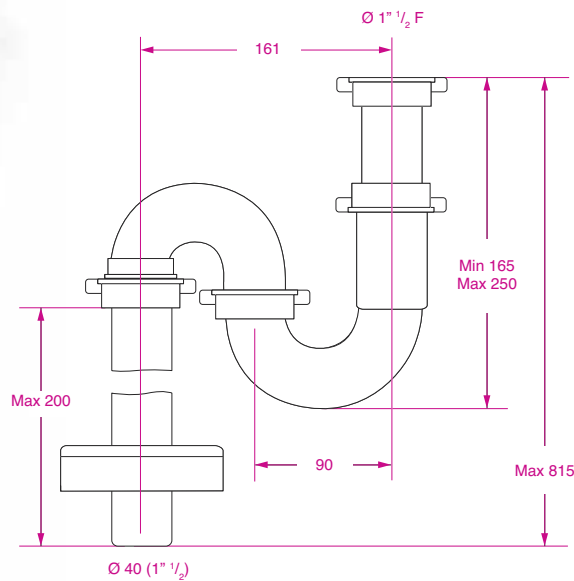

Sifone a "TUBO"  
per lavello ad una vasca.  
Completo di raccordo con  
scarico a pavimento.  
(Piletta non inclusa).  
Corpo grigio metallizzato.

Polypropylene "P" trap  
for single bowl sink.  
(Waste drainer not included).  
Silver grey body.

PSV 40

Peso / Weight 260 g

cod. 02.01.50001

### PSB 1225 > SIFONE / TRAP

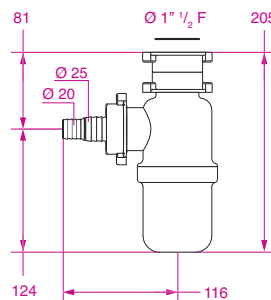

Sifone a "BOTTIGLIA"  
per lavello ad una vasca.  
(Piletta non inclusa).  
Corpo grigio metallizzato.

"BOTTLE" trap for  
single bowl sink  
(Waste drainer not included).  
Silver grey body.

PSB 1225

Peso / Weight 216 g

cod. 02.01.50004

Misure in millimetri / Measurements in millimeters

**PI 1260 GP > SINGOLA / SINGLE > SCARICO DA 1"1/2 M GAS / DRAINER 1"1/2 M BSP**

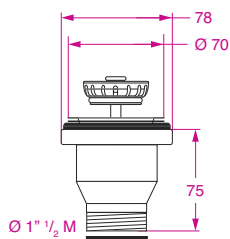

Adatta a foro Ø min. 56 mm.  
Con griglia estraibile  
con funzione di tappo.  
Corpo grigio metallizzato.

Suitable for hole min. 56 mm.  
With removable grid  
with plug function.  
Silver grey body.

**PI 1260 GP**

Peso / Weight 209 g

**cod. 02.01.20030**

**P2 1260 > DOPPIA / DOUBLE > KIT PER TUBI Ø 40 MM / KIT FOR HOSES DIA 40 MM**

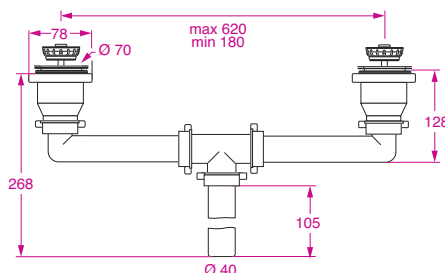

Adatta a fori Ø min. 56 mm.  
Con griglia estraibile  
con funzione di tappo.  
Corpo grigio metallizzato.

Suitable for holes min. 56 mm.  
With removable grid  
with plug function.  
Silver grey body.

**P2 1260**

Peso / Weight 688 g

**cod. 02.01.23101**

**P2 1260/32 > DOPPIA / DOUBLE > KIT PER TUBI Ø 32 MM / KIT FOR HOSES DIA 32 MM**

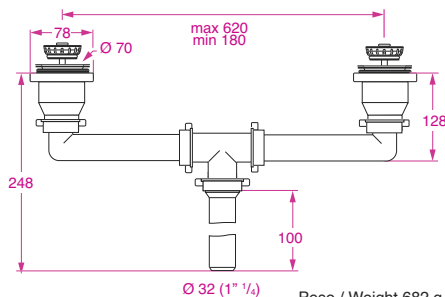
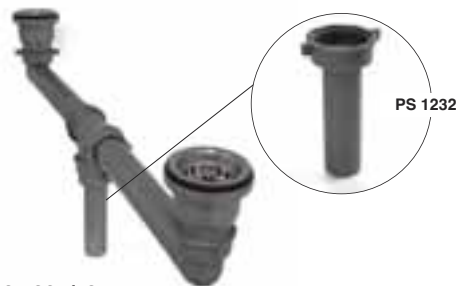

Adatta a fori Ø min. 56 mm.  
Con griglia estraibile  
con funzione di tappo.  
Corpo grigio metallizzato.

Suitable for holes min. 56 mm.  
With removable grid  
with plug function.  
Silver grey body.

**P2 1260/32**

Peso / Weight 682 g

**cod. 02.01.23104**

**P2 1260/25 > DOPPIA / DOUBLE > KIT PER TUBI Ø 25 MM / KIT FOR HOSES DIA 25 MM**

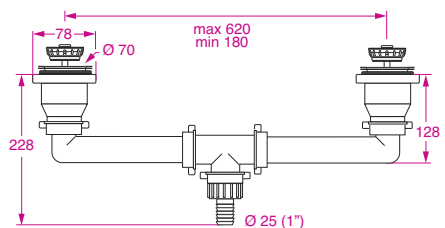

Adatta a fori Ø min. 56 mm.  
Con griglia estraibile  
con funzione di tappo.  
Corpo grigio metallizzato.

Suitable for holes min. 56 mm.  
With removable grid  
with plug function.  
Silver grey body.

**P2 1260/25**

Peso / Weight 674 g

**cod. 02.01.23103**

**P2 1260/20 > DOPPIA / DOUBLE > KIT PER TUBI Ø 20 MM / KIT FOR HOSES DIA 20 MM**

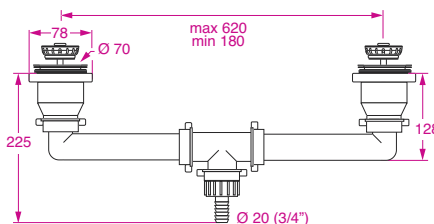

Adatta a fori Ø min. 56 mm.  
Con griglia estraibile  
con funzione di tappo.  
Corpo grigio metallizzato.

Suitable for holes min. 56 mm.  
With removable grid  
with plug function.  
Silver grey body.

**P2 1260/20**

Peso / Weight 674 g

**cod. 02.01.23102**

Tutte le pilette elencate, sono adatte ai nostri fori, salvo diversamente indicato  
All drainers are suited for our holes, unless otherwise specified

# PILETTE DI SCARICO PER FORO 3" 1/2 / WASTE DRAINERS FOR HOLE 3" 1/2

**PF 4090 GP > SINGOLA / SINGLE > SCARICO DA 1"1/2 M GAS / DRAINER 1"1/2 M BSP**

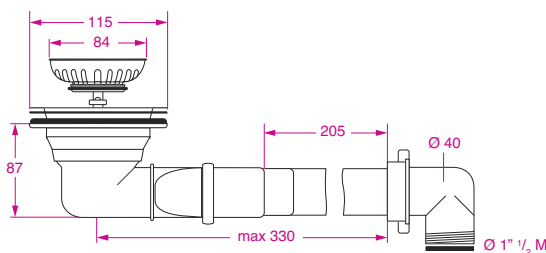

Adatta a foro Ø min. 88 mm.  
Con griglia estraibile  
con funzione di tappo.  
Corpo grigio metallizzato.

Suitable for hole min. 88 mm.  
With removable grid  
with plug function.  
Silver grey body.

PF 4090 GP

Peso / Weight 435 g

cod. 02.01.30040

**PDX 4090 GP > DOPPIA / DOUBLE > KIT PER TUBI Ø 40 MM / KIT FOR HOSES DIA 40 MM**

PI 1290 GP

PF4090 GP



PS 1240

**PER LAVELLI  
SCALINATI**

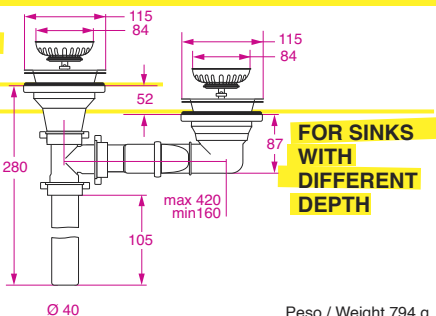

Adatta a fori Ø min. 88 mm.  
**Kit per lavelli scalinati.**  
Con griglia estraibile  
con funzione di tappo.  
Corpo grigio metallizzato

Suitable for holes min. 88 mm.  
**Kit for sinks with  
different depth.**  
With removable grid with plug  
function. Silver grey body.

PDX 4090 GP

Peso / Weight 794 g

cod. 02.01.30004

**PDX 4090/32 > DOPPIA / DOUBLE > KIT PER TUBI Ø 32 MM / KIT FOR HOSES DIA 32 MM**



PS 1232

**PER LAVELLI  
SCALINATI**

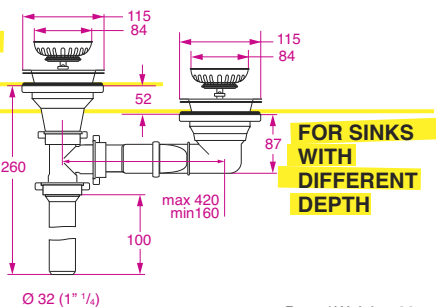

Adatta a fori Ø min. 88 mm.  
**Kit per lavelli scalinati.**  
Con griglia estraibile  
con funzione di tappo.  
Corpo grigio metallizzato

Suitable for holes min. 88 mm.  
**Kit for sinks with  
different depth.**  
With removable grid with plug  
function. Silver grey body.

PDX 4090/32

Peso / Weight 788 g

cod. 02.01.30005

**P2F 4090 GP > DOPPIA / DOUBLE > KIT PER TUBI Ø 40 MM / KIT FOR HOSES DIA 40 MM**



PS 1240

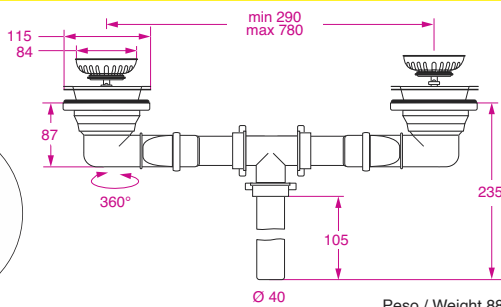

Adatta a fori Ø min. 88 mm.  
Con griglia estraibile  
con funzione di tappo.  
Corpo grigio metallizzato.

Suitable for holes min. 88 mm.  
With removable grid  
with plug function.  
Silver grey body.

P2F 4090 GP

Peso / Weight 884 g

cod. 02.01.30043

**P2F 4090/32 > DOPPIA / DOUBLE > KIT PER TUBI Ø 32 MM / KIT FOR HOSES DIA 32 MM**



PS 1232

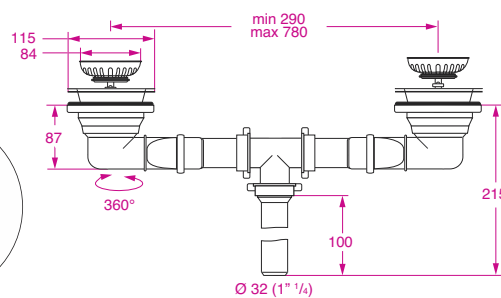

Adatta a fori Ø min. 88 mm.  
Con griglia estraibile  
con funzione di tappo.  
Corpo grigio metallizzato.

Suitable for holes min. 88 mm.  
With removable grid  
with plug function.  
Silver grey body.

P2F 4090/32

Peso / Weight 878 g

cod. 02.01.30042

Misure in millimetri / Measurements in millimeters



**PI 1290 GP > SINGOLA / SINGLE > SCARICO DA 1"1/2 M GAS / DRAINER 1"1/2 M BSP**

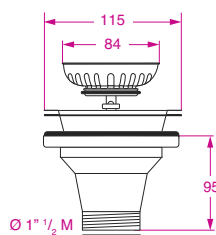

Adatta a foro Ø min. 88 mm.  
Con griglia estraibile  
con funzione di tappo.  
Corpo grigio metallizzato.

Suitable for hole min. 88 mm.  
With removable grid  
with plug function.  
Silver grey body.

**PI 1290 GP**

Peso / Weight 310 g

**cod. 02.01.30000**

**PD 1290 GP > DOPPIA / DOUBLE > KIT PER TUBI Ø 40 MM / KIT FOR HOSES DIA 40 MM**

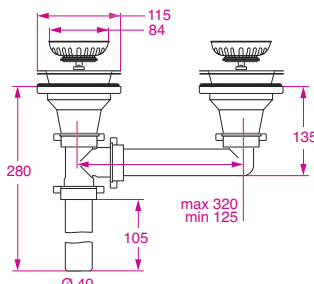

Adatta a fori Ø min. 88 mm.  
Con griglia estraibile  
con funzione di tappo.  
Corpo grigio metallizzato.

Suitable for holes min. 88 mm.  
With removable grid  
with plug function.  
Silver grey body.

**PD 1290 GP**

Peso / Weight 797 g

**cod. 02.01.30002**

**PD 1290/32 > DOPPIA / DOUBLE > KIT PER TUBI Ø 32 MM / KIT FOR HOSES DIA 32 MM**

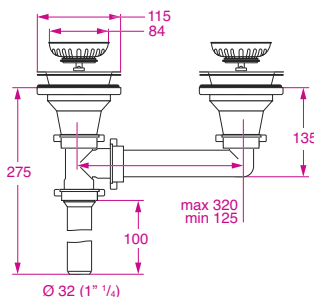

Adatta a fori Ø min. 88 mm.  
Con griglia estraibile  
con funzione di tappo.  
Corpo grigio metallizzato.

Suitable for holes min. 88 mm.  
With removable grid  
with plug function.  
Silver grey body.

**PD 1290/32**

Peso / Weight 791 g

**cod. 02.01.30006**

**P2 1290 GP > DOPPIA / DOUBLE > KIT PER TUBI Ø 40 MM / KIT FOR HOSES DIA 40 MM**

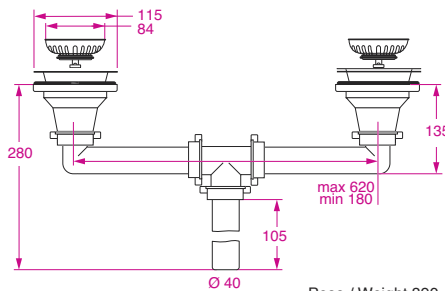

Adatta a fori Ø min. 88 mm.  
Con griglia estraibile  
con funzione di tappo.  
Corpo grigio metallizzato.

Suitable for holes min. 88 mm.  
With removable grid  
with plug function.  
Silver grey body.

**P2 1290 GP**

Peso / Weight 890 g

**cod. 02.01.30003**

**P2 1290/32 > DOPPIA / DOUBLE > KIT PER TUBI Ø 32 MM / KIT FOR HOSES DIA 32 MM**

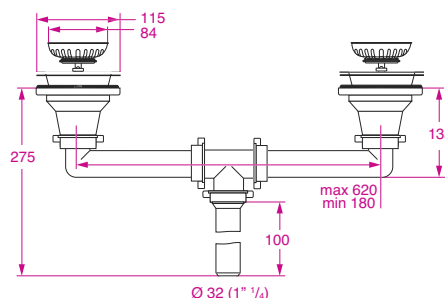

Adatta a fori Ø min. 88 mm.  
Con griglia estraibile  
con funzione di tappo.  
Corpo grigio metallizzato.

Suitable for holes min. 88 mm.  
With removable grid  
with plug function.  
Silver grey body.

**P2 1290/32**

Peso / Weight 884 g

**cod. 02.01.30007**

Tutte le pilette elencate, sono adatte ai nostri fori, salvo diversamente indicato  
All drainers are suited for our holes, unless otherwise specified

**PS 1432 - PS 1432 G**

TUBO DI SCARICO DRITTO / STRAIGHT DRAIN PIPE

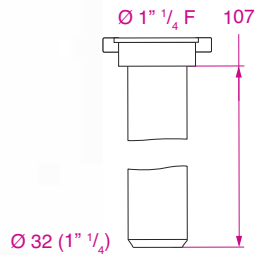

**PS 1432**

**cod. 02.01.10100**

**PS 1432 G**

Peso / Weight 31 g

**cod. 02.01.10101**

**PS 1240/LAVG > TUBO DRITTO / STRAIGHT PIPE**

con attacco per lavapiatti / with side hose rail for dishwasher

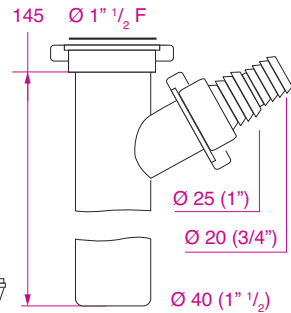

**PS 1240/LAVG**

Peso / Weight 78 g

**cod. 02.01.20201**

**PS 1232 > TUBO DI SCARICO DRITTO /**

**STRAIGHT DRAIN PIPE**

**< PS 1240**

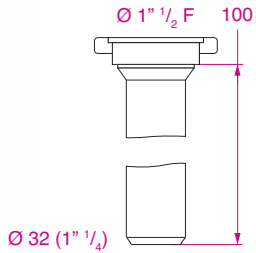

**PS 1232**

Peso / Weight 31 g

**cod. 02.01.20101**

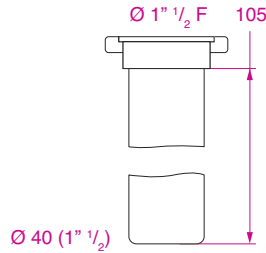
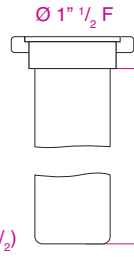

**PS 1240**

Peso / Weight 37 g

**cod. 02.01.20100**

**PE 1240 > TUBO A GOMITO / ELBOW PIPE**

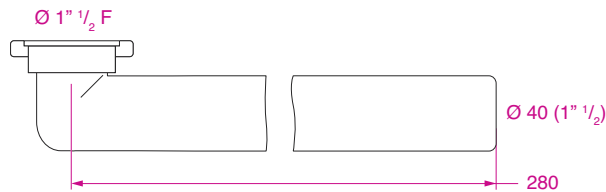

**PE 1240**

Peso / Weight 88 g

**cod. 02.01.20300**

**PE 1432 > TUBO A GOMITO / ELBOW PIPE**

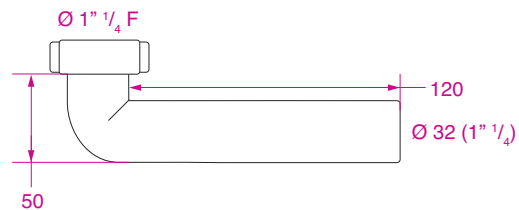

**PE 1432**

Peso / Weight 31 g

**cod. 02.01.10300**

**PT 3232 > RACCORDO A "T" / "T" ADAPTOR**

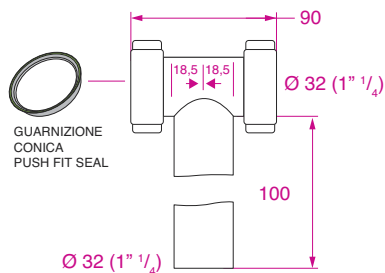

**PT 3232**

Peso / Weight 47 g

**cod. 02.01.10400**

UN'AMPIA GAMMA DI PILETTE E ACCESSORI DI DIVERSE TIPOLOGIE ADATTE ALLE DIVERSE ESIGENZE DI INSTALLAZIONE E PENSATE PER AVERE IL MINORE INGOMBRO POSSIBILE CONSIDERATI GLI SPAZI RISTRETTI DELLE BARCHE DA DIPORTO

Misure in millimetri / Measurements in millimeters

## ACCESSORI E RICAMBI / ACCESSORIES AND SPARE PARTS

### PG 1420 > PORTAGOMMA DRITTO / HOSE-TAIL

con ghiera mobile / with mobile threaded ring nut

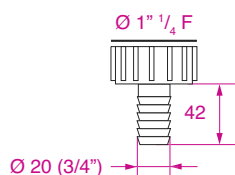

**PG 1420**      Peso / Weight 23 g      **cod. 04.20.11420**

### PG 1425 > PORTAGOMMA DRITTO / HOSE-TAIL

con ghiera mobile / with mobile threaded ring nut

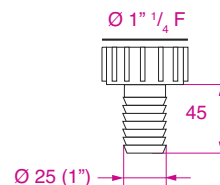

**PG 1425**      Peso / Weight 23 g      **cod. 04.20.11425**

### PA 1214 > RIDUZIONE / ADAPTOR

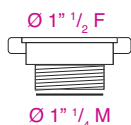

**PA 1214**      Peso / Weight 13 g      **cod. 02.02.00001**

### PA 1412 > RIDUZIONE / ADAPTOR

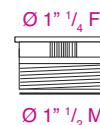

**PA 1412**      Peso / Weight 17 g      **cod. 02.02.00002**

### PGE > RIDUZIONE / ADAPTOR

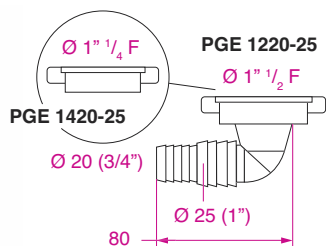

**PGE 1220-25**      **cod. 02.02.00003**  
**PGE 1420-25**      Peso / Weight 25 g      **cod. 02.02.00005**

### GRD 12 > GRIGLIA ESTRAIBILE / REMOVABLE GRID

Ricambio per / Spare part for **PI 1235 GR - PF 2535 GR**

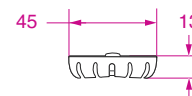

**GRD 12**      Peso / Weight 16 g      **cod. 02.02.04010**

### PLGMXX > TAPPO / PLUG

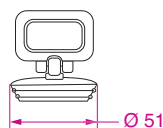

**PLGMXX**      Peso / Weight 22 g      **cod. 02.02.00102**

### PLG 35 > TAPPO / PLUG

con catenella / with chain

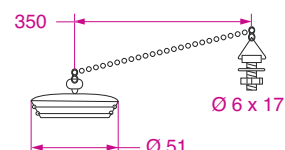

**PLG 35**      Peso / Weight 50 g      **cod. 02.02.00110**

### PT 4040 > RACCORDO A "T" / "T" CONNECTION

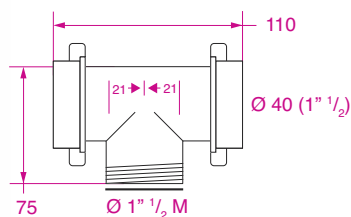

**PT 4040**      Peso / Weight 57 g      **cod. 02.01.20400**

### PT 4040 S > RACCORDO A "T" / "T" CONNECTION

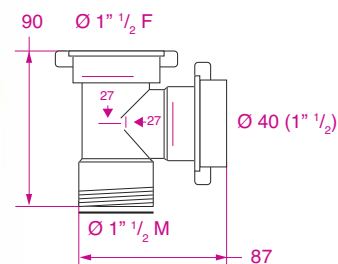

**PT 4040 S**      Peso / Weight 52 g      **cod. 02.01.20401**

Misure in millimetri / Measurements in millimeters

## PILETTINE SPECIALI / REDUCED SIZE DRAINERS

PER FORI DI PICCOLE DIMENSIONI Ø 25 O Ø 30 MM / FOR SPECIAL SMALL HOLES DIA 25 OR DIA 30 MM

Non adatte ai fori dei nostri lavelli / Not suitable for our sinks holes

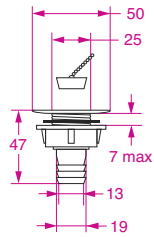

**PIST 20**

Peso / Weight 23 g

**cod. 02.10.00000**

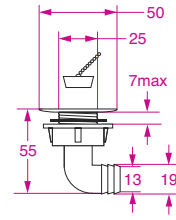

**PIEL 20**

Peso / Weight 26 g

**cod. 02.10.00010**

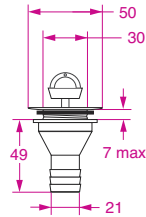

**PIST 20 F**

Peso / Weight 18 g

**cod. 02.10.00001**

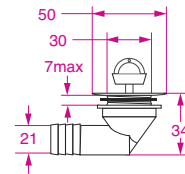

**PIEL 20 F**

Peso / Weight 21 g

**cod. 02.10.00011**

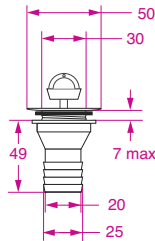

**PIST 25 F**

Peso / Weight 19 g

**cod. 02.10.00101**

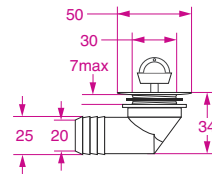

**PIEL 25 F**

Peso / Weight 22 g

**cod. 02.10.00111**



Misure in millimetri / Measurements in millimeters



# MISCELATORI CERAMICI MONOCOMANDO / ONE HANDLE MIXERS

## MJA 1000 - 1/2" F – MJA 1000 K - 1/2" F

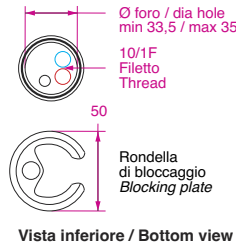
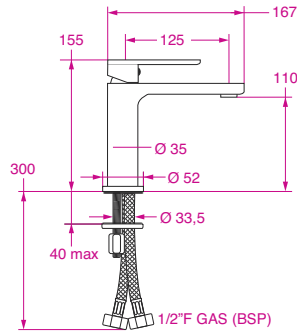

Miscelatore a bocca fissa, con aeratore.  
Corpo in ottone.  
Fornito con flessibili sottorubinetti **FLX 101235**, lunghezza 35 cm.

Basin mixer with fixed spout, and aerator.  
Brass body.  
Supplied with under tap flex **FLX 101235** length 35 cm.

**MJA 1000 - 1/2" F**

Cromato / Chrome

**cod. 03.11.01500**

**MJA 1000 K - 1/2" F**

NERO MAT / BLACK MAT

Peso / Weight 1,046 Kg

**cod. 03.11.01505**

## MKY 1000 - 1/2" F – MKY 1000 K - 1/2" F

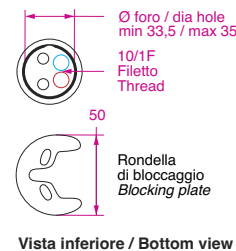
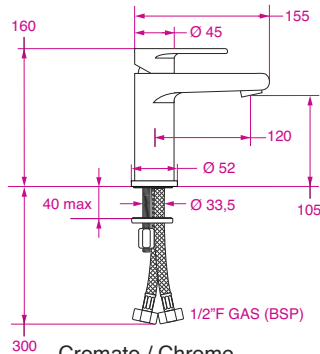

Miscelatore a bocca fissa, con aeratore.  
Corpo in ottone.  
Fornito con flessibili sottorubinetti **FLX 101235**, lunghezza 35 cm.

Basin mixer with fixed spout, and aerator.  
Brass body.  
Supplied with under tap flex **FLX 101235** length 35 cm.

**MKY 1000 - 1/2" F**

Cromato / Chrome

**cod. 03.11.01405**

**MKY 1000 K - 1/2" F**

NERO MAT / BLACK MAT

Peso / Weight 1,206 Kg

**cod. 03.11.01406**

## MJO 1000 - 1/2" F – MJO 1000 K - 1/2" F

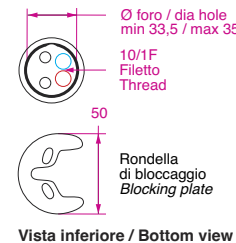
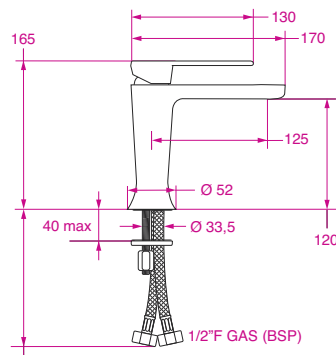

Miscelatore a bocca fissa, con aeratore.  
Corpo in ottone.  
Fornito con flessibili sottorubinetti **FLX 101235**, lunghezza 35 cm.

Basin mixer with fixed spout, and aerator.  
Brass body.  
Supplied with under tap flex **FLX 101235** length 35 cm.

**MJO 1000 - 1/2" F**

Cromato / Chrome

**cod. 03.11.01401**

**MJO 1000 K - 1/2" F**

NERO MAT / BLACK MAT

Peso / Weight 1,092 Kg

**cod. 03.11.01402**

## MJ 1000

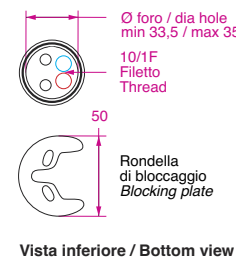
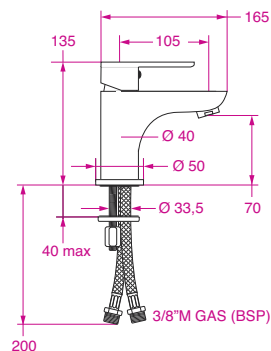

Miscelatore a bocca fissa, con aeratore.  
Corpo in ottone cromato.  
Fornito con flessibili sottorubinetti **FLX 103821**

Basin mixer with fixed spout, and aerator.  
Chrome brass body.  
Supplied with under tap flex **FLX 103821**

**MJ 1000**

Peso / Weight 1,040 Kg

**cod. 03.11.01400**

Tutte le misure sono espresse in millimetri  
All measurements are in millimeters





**BB 0600**

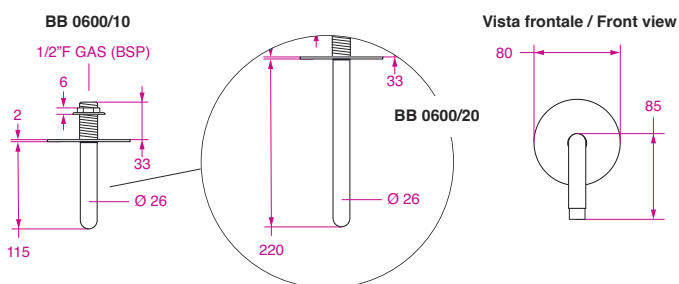

Bocca fissa,  
con aeratore  
Costruito in ottone.

Fixed spout,  
with aerator  
Brass body.

<b>BB 0600/10</b>	Cromato / Chrome	Peso / Weight 0,303 Kg	<b>cod. 03.11.02000</b>
<b>BB 0600 K/10</b>	NERO MAT / BLACK MAT		<b>cod. 03.11.02001</b>
<b>BB 0600/20</b>	Cromato / Chrome		<b>cod. 03.11.02002</b>

**MRL 1600 - 1/2\"/>**

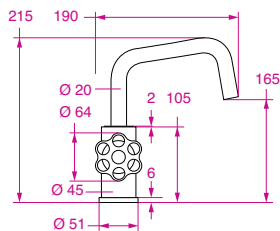

Vista laterale / Side view

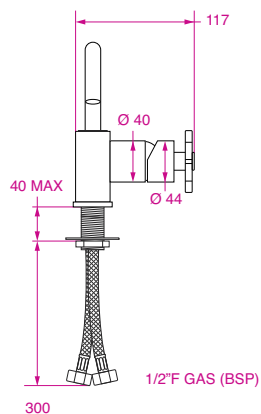

Vista frontale / Front view



Vista inferiore / Bottom view



Miscelatore a bocca fissa,  
con aeratore.  
Costruito in ottone cromato.  
Fornito con flessibili  
sottorubinetti **FLX 101235**,  
lunghezza 35 cm.

Basin mixer with fixed spout,  
and aerator.  
Chrome brass body.  
Supplied with under tap flex  
**FLX 101235** length 35 cm.

**MRL 1600 - 1/2\"/>**

Peso / Weight 1,408 Kg

**cod. 03.11.02010**

# MISCELATORI CERAMICI MONOCOMANDO / ONE HANDLE MIXERS

## MY 1000 – MY 1000 B

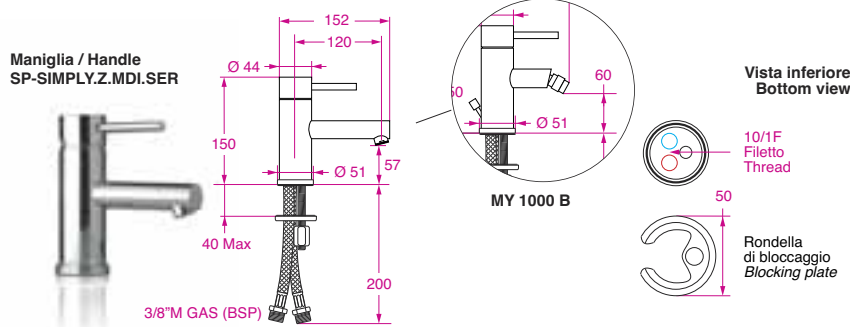

Miscelatore a bocca fissa, con aeratore.  
Corpo in ottone cromato.  
Fornito con flessibili sottorubinetti **FLX 103821**.

Basin mixer with fixed spout, and aerator.  
Chrome brass body.  
Supplied with under tap flex **FLX 103821**.

<b>MY 1000</b>	<b>MY 1000</b>	Peso / Weight 1,440 Kg	<b>cod. 03.10.00500</b>
<b>MY 1000 B</b>	Con piletta a saltarello / With pop-up waste drainer	Peso / Weight 1,490 Kg	<b>cod. 03.10.00510</b>

## MY 1000 L-3/8" F

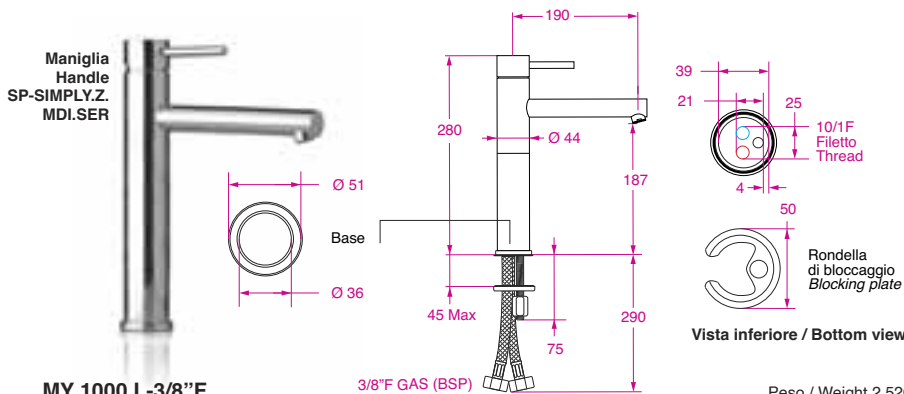

Miscelatore a bocca fissa, con aeratore.  
Corpo in ottone cromato.  
Fornito con flessibili sottorubinetti **10/1 F – 3/8\"/>**

Basin mixer with fixed spout, and aerator.  
Chrome brass body.  
Supplied with under tap flex **10/1 F – 3/8\"/>**

<b>MY 1000 L-3/8" F</b>	<b>3/8" F GAS (BSP)</b>	Peso / Weight 2,520 Kg	<b>cod. 03.10.00520</b>
-------------------------	-------------------------	------------------------	-------------------------

## MY 1800 X-1/2" F

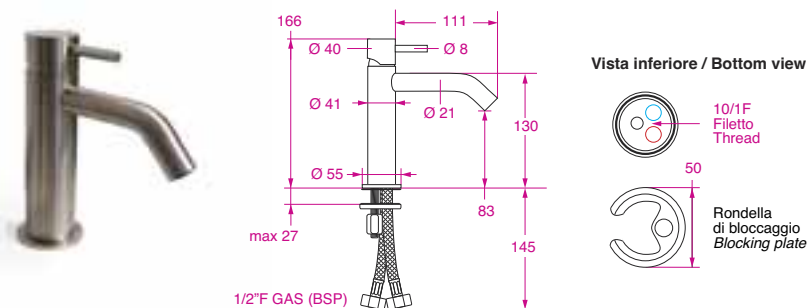

Miscelatore a bocca fissa, con aeratore.  
In **ACCIAIO INOX 316**.  
Fornito con flessibili sottorubinetti **FLX 101235**, lunghezza 35 cm.

Basin mixer with fixed spout, and aerator.  
Built **S/S STEEL 316**  
Supplied with under tap flex **FLX 101235** length 35 cm.

<b>MY 1800 X-1/2" F</b>	<b>1/2" F GAS (BSP)</b>	Peso / Weight 835 g	<b>cod. 03.10.10001</b>
-------------------------	-------------------------	---------------------	-------------------------

## MY 1700 K-1/2" F

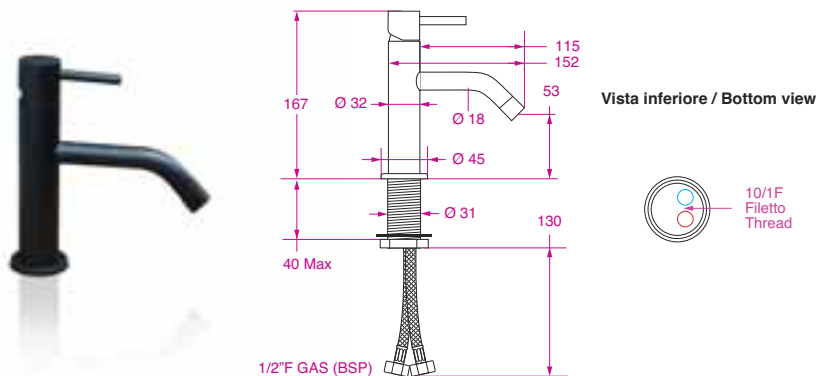

Miscelatore a bocca fissa, con aeratore.  
In ottone, **NERO MAT**.  
Fornito con flessibili sottorubinetti **FLX 101235**, lunghezza 35 cm.

Basin mixer with fixed spout, and aerator.  
All **BLACK MAT** brass.  
Supplied with under tap flex **FLX 101235** length 35 cm.

<b>MY 1700 K-1/2" F</b>	<b>1/2" F GAS (BSP)</b>	Peso / Weight 771 g	<b>cod. 03.10.00455</b>
-------------------------	-------------------------	---------------------	-------------------------

Tutte le misure sono espresse in millimetri  
All measurements are in millimeters



MY 1600

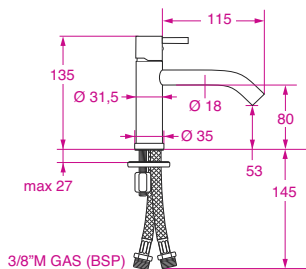

Vista inferiore / Bottom view

Miscelatore a bocca fissa, con aeratore. Costruito in ottone cromato. Fornito con flessibili sottorubinetti **FLX 813821**.

Basin mixer with fixed spout, and aerator. Made in chrome brass. Supplied with under tap flex **FLX 813821**.

MY 1600

Peso / Weight 648 g

cod. 03.10.0040

MQ 1000

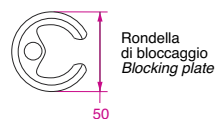
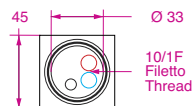
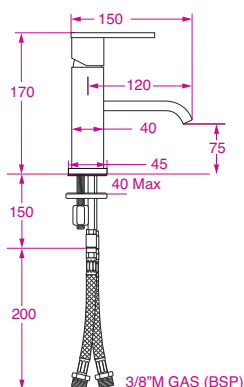

Vista inferiore / Bottom view

Miscelatore a bocca fissa, con rompigetto. Costruito in ottone cromato. Fornito con flessibili sottorubinetti **FLX 103821**.

Basin mixer with fixed spout, and flow breaker. Made in chrome brass. Supplied with under tap flex **FLX 103821**.

MQ 1000

Peso / Weight 1,552 Kg

cod. 03.11.00300

MQL 1500

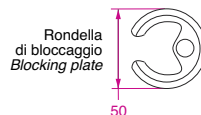
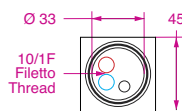
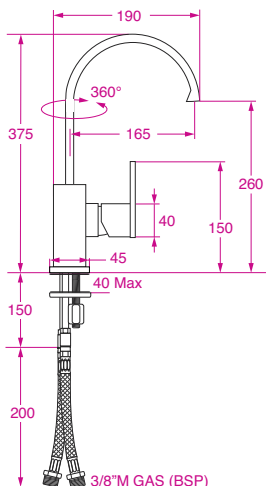

Vista inferiore / Bottom view

Miscelatore con canna girevole, con aeratore. Costruito in ottone cromato. Fornito con flessibili sottorubinetti **FLX 103821**.

Mixer with swivel spout, and aerator. Made in chrome brass. Supplied with under tap flex **FLX 103821**.

MQL 1500

Peso / Weight 2,188 Kg

cod. 03.11.00200

MQL 1500 B

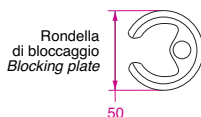
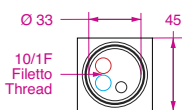
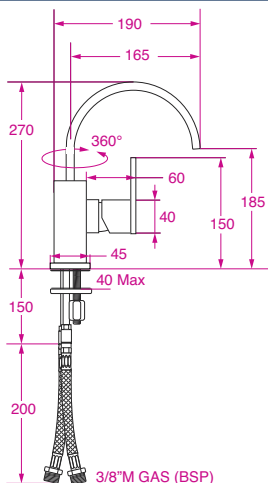

Vista inferiore / Bottom view

Miscelatore con canna girevole, con rompigetto. Costruito in ottone cromato. Con piletta a saltarello. Fornito con flessibili sottorubinetti **FLX 103821**.

Mixer with swivel spout, and flow breaker. Made in chrome brass. With pop-up waste. Supplied with under tap flex **FLX 103821**.

MQL 1500 B

Peso / Weight 2,474 Kg

cod. 03.11.00210

# MISCELATORI CERAMICI MONOCOMANDO / ONE HANDLE MIXERS

## MM 6000

Maniglia / Handle  
KIMMY SERIGRAFATA

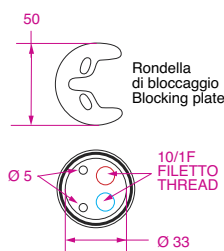
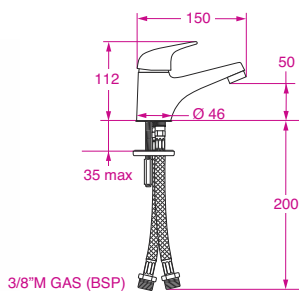

Vista inferiore / Bottom view

Miscelatore a bocca fissa,  
con aeratore.  
Corpo in ottone cromato.  
Fornito con flessibili  
sottorubinetto **FLX 103821**.

Basin mixer with fixed spout,  
and aerator.  
Chrome brass body.  
Supplied with under tap flex  
**FLX 103821**.

MM 6000

Peso / Weight 908 g

cod. 03.05.07000

## MM 7000

Maniglia / Handle  
LEVA 7 BETA

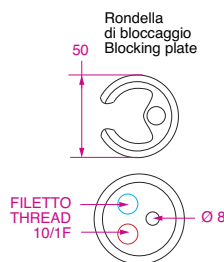
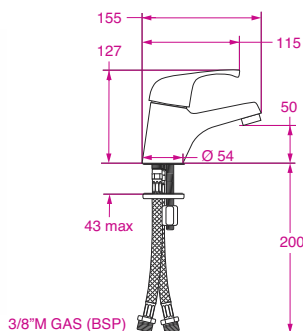

Vista inferiore / Bottom view

Miscelatore a bocca fissa,  
con aeratore.  
Corpo in ottone cromato.  
Fornito con flessibili  
sottorubinetto **FLX 103821**.

Basin mixer with fixed spout,  
and aerator.  
Chrome brass body.  
Supplied with under tap flex  
**FLX 103821**.

MM 7000

Peso / Weight 1,120 Kg

cod. 03.05.17000

## MM 8000

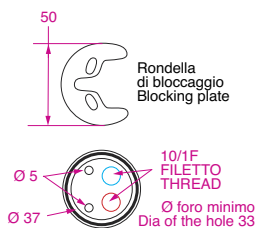
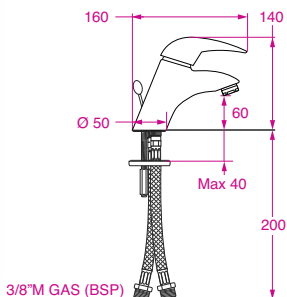

Vista inferiore / Bottom view

Miscelatore a bocca fissa,  
con aeratore.  
Corpo in ottone cromato.  
Fornito con flessibili  
sottorubinetto **FLX 103821**.

Basin mixer with fixed spout,  
and aerator.  
Chrome brass body.  
Supplied with under tap flex  
**FLX 103821**.

MM 8000

Con piletta a saltarello / With pop-up waste

Peso / Weight 1,762 Kg

cod. 03.05.27000

## ML 6500

Maniglia/Handle  
KIMMY SERIGRAFATA

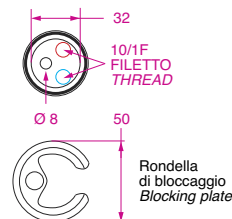
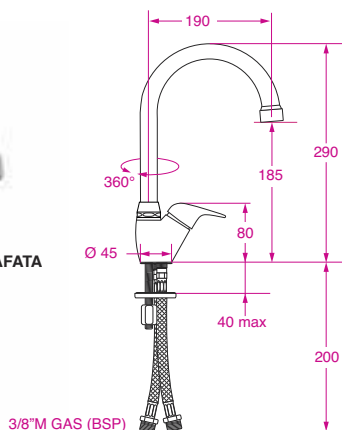

Vista inferiore / Bottom view

Miscelatore da cucina  
con canna girevole e aeratore.  
Corpo in ottone cromato.  
Fornito con flessibili  
sottorubinetto **FLX 103821**.

Sink mixer with swivel spout,  
and aerator.  
Chrome brass body.  
Supplied with under tap flex  
**FLX 103821**.

ML 6500

Peso / Weight 1,076 Kg

cod. 03.06.06000

Tutte le misure sono espresse in millimetri  
All measurements are in millimeters

**MM 6700/15**

Maniglia / Handle  
KIMMY SERIGRAFATA

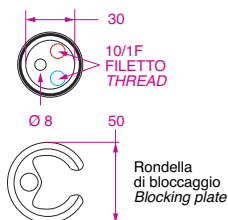
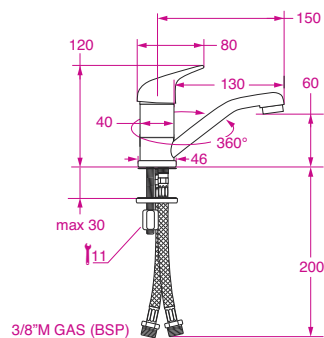

Vista inferiore / Bottom view

Miscelatore da cucina con canna girevole e aeratore. Corpo in ottone cromato. Fornito con flessibili sottorubinetto **FLX 103821**.

Sink mixer with swivel spout, and aerator. Chrome brass body. Supplied with under tap flex **FLX 103821**.

**MM 6700/15**

Peso / Weight 810 g

**cod. 03.06.01000**

**MM 6700/20**

Maniglia / Handle  
KIMMY SERIGRAFATA

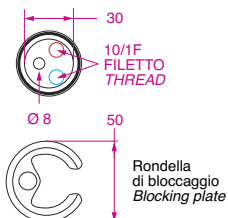
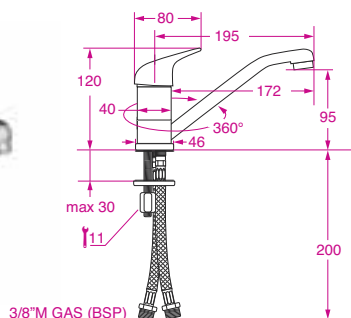

Vista inferiore / Bottom view

Miscelatore da cucina con canna girevole e aeratore. Corpo in ottone cromato. Fornito con flessibili sottorubinetto **FLX 103821**.

Sink mixer with swivel spout, and aerator. Chrome brass body. Supplied with under tap flex **FLX 103821**.

**MM 6700/20**

Peso / Weight 840 g

**cod. 03.06.02000**

**MM 6700/25**

Maniglia / Handle  
KIMMY SERIGRAFATA

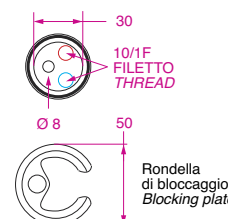
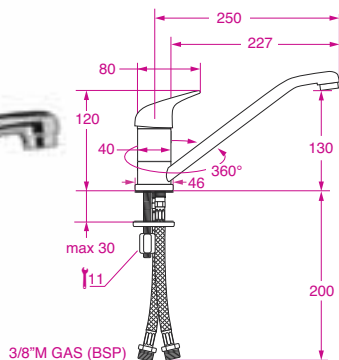

Vista inferiore / Bottom view

Miscelatore da cucina con canna girevole e aeratore. Corpo in ottone cromato. Fornito con flessibili sottorubinetto **FLX 103821**.

Sink mixer with swivel spout, and aerator. Chrome brass body. Supplied with under tap flex **FLX 103821**.

**MM 6700/25**

Peso / Weight 850 g

**cod. 03.06.03000**

**MM 7700**

Maniglia / Handle  
LEVA 7 BETA

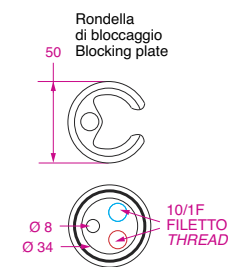
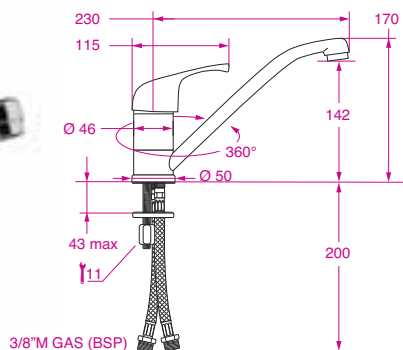

Vista inferiore / Bottom view

Miscelatore da cucina con canna girevole e aeratore. Corpo in ottone cromato. Fornito con flessibili sottorubinetto **FLX 103821**.

Sink mixer with swivel spout, and aerator. Chrome brass body. Supplied with under tap flex **FLX 103821**.

**MM 7700**

Peso / Weight 1,180 Kg

**cod. 03.06.01000**

Tutte le misure sono espresse in millimetri  
All measurements are in millimeters

# MISCELATORI CERAMICI MONOCOMANDO / ONE HANDLE MIXERS

## MY 1820-1/2" F

Maniglia / Handle LEVA MINIMALISTA

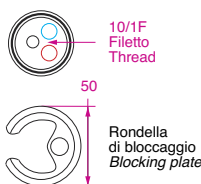
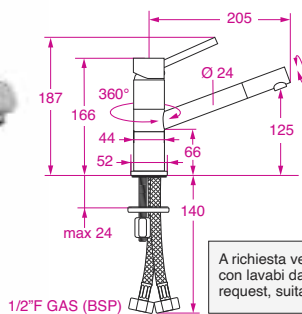

Vista inferiore / Bottom view

A richiesta versioni più alte per utilizzo in combinazione con lavabi da appoggio. / Taller versions available on request, suitable for over the top basins.

Miscelatore con canna girevole e rotante, con aeratore. Corpo in ottone cromato. Fornito con flessibili sottorubinetto **FLX 101221**.

Mixer with swivel and rotating spout, with aerator. Chrome brass body. Supplied with under tap flex **FLX 101221**.

MY 1820-1/2" F

Peso / Weight 1,734 Kg

cod. 03.10.00100

## MY 1822-1/2" F > DOCCIA ESTRAIBILE / PULL OUT SHOWER

Maniglia / Handle LEVA MINIMALISTA

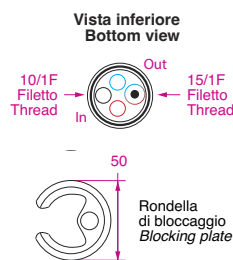
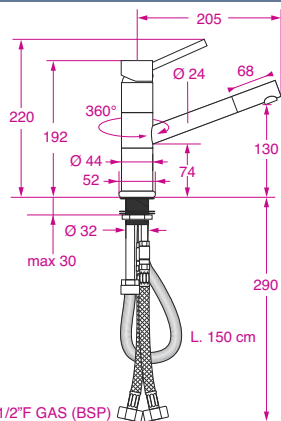

Vista inferiore Bottom view

Miscelatore con canna girevole e bocca estraibile, con aeratore. Corpo in ottone cromato. Fornito con flex **TP 1515-MM** (15/1M x 15/1M) e con flessibili sottorubinetto **FLX 101221**.

Mixer with swivel and pull-out spout, with aerator. Chrome brass body. Supplied with flex **TP 1515-MM** (15/1M x 15/1M) and under tap flex **FLX 101221**.

MY 1822-1/2" F

Peso / Weight 2,069 Kg

cod. 03.10.00110

## MDY 1401-1/2" F > DOCCIA ESTRAIBILE / PULL OUT SHOWER

Maniglia / Handle LEVA MINIMALISTA

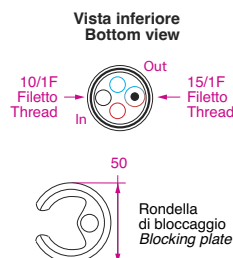
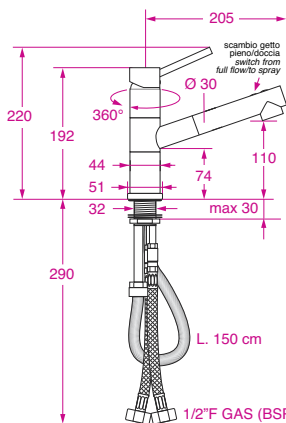

Vista inferiore Bottom view

Miscelatore con canna girevole ed estraibile, a doppio getto con aeratore. Corpo in ottone cromato. Fornito con flex **TP 1538-M** e con flessibili sottorubinetto **FLX 101221**.

Mixer with swivel and pull-out spout, adjustable flow shower, full and spray flow, with aerator. Chrome brass body. Supplied with flex **TP 1538-M** and under tap flex **FLX 101221**.

MDY 1401-1/2" F

Peso / Weight 1,860 Kg

cod. 03.10.00121

## MYL 1500

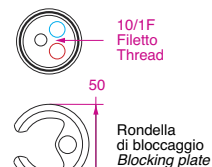
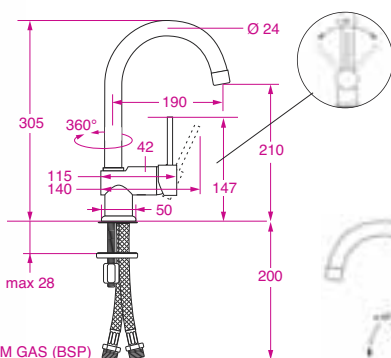

Vista inferiore / Bottom view

A richiesta disponibile nella versione con una speciale cartuccia di miscelazione che sposta di 45° in avanti l'angolo di lavoro eliminando la sporgenza posteriore, consentendo un montaggio molto vicino alla parete.

Available on request an optional version with a special mixing cartridge that shift of 45° forward the working angle removing the back protrusion thus allowing an installation close to the back wall.

Miscelatore con canna girevole e aeratore. Costruito in ottone cromato. Fornito con flessibili sottorubinetto **FLX 103821**.

Mixer with swivel spout, and aerator. Made in chrome brass. Supplied with under tap flex **FLX 103821**.

MYL 1500

Peso / Weight 1,560 Kg

Optional MYL 1501  
cod. 03.10.00702

cod. 03.10.00700

Tutte le misure sono espresse in millimetri  
All measurements are in millimeters

Deviatore getto pieno / doccia  
Full flow / shower switch

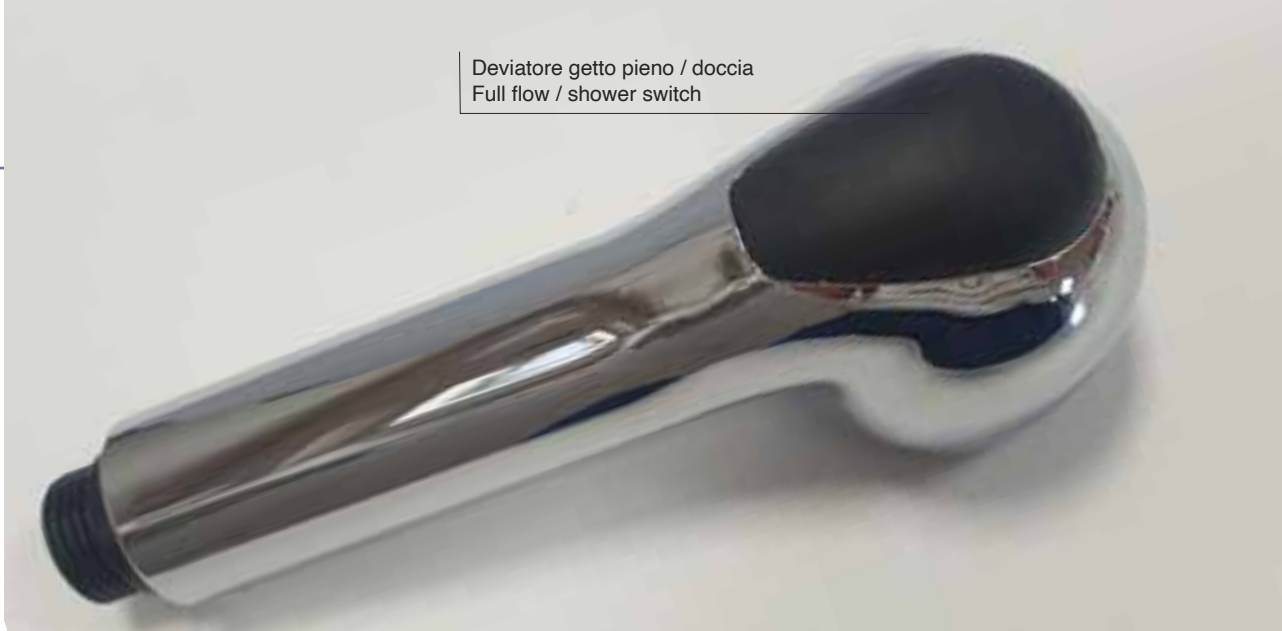

**MD 7551 – MD 7552 > DOCCIA ESTRAIBILE / PULL OUT SHOWER**

Maniglia / Handle  
LEVA 7 BETA



D 55

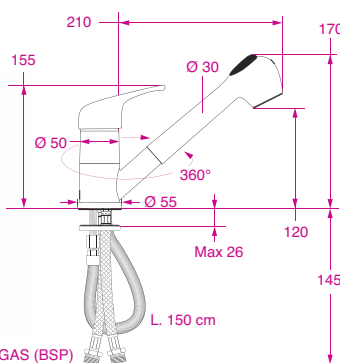

3/8" M GAS (BSP)

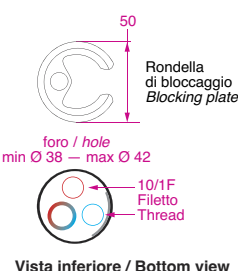

Vista inferiore / Bottom view

Peso / Weight 1,450 Kg

Miscelatore con doccia girevole, estraibile ed orientabile, a doppio getto, con anticalcare. Corpo in ottone cromato. Fornito con flex **TC 1538-M** e con flessibili sottorubinetto **FLX 103821**.

Mixer with swivel, pull-out, adjustable flow shower, with anti-scale. Chrome brass body. Supplied with flex **TC 1538-M** and under tap flex **FLX 103821**.

**MD 7551**

**cod. 03.08.05501**

**MD 7552** Con flessibile da 2 m / With 2 m flex

**cod. 03.08.05502**

**MD 6551 – MD 6552 > DOCCIA ESTRAIBILE / PULL OUT SHOWER**

Maniglia / Handle  
KIMMY SERIGRAFATA



D 55

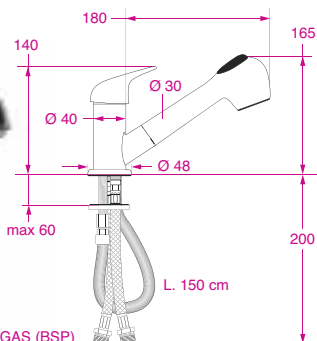

3/8" M GAS (BSP)

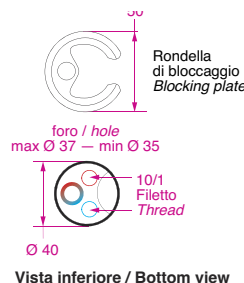

Vista inferiore / Bottom view

Peso / Weight 1,155 Kg

Miscelatore con doccia estraibile, a doppio getto, non orientabile, con anticalcare. Corpo in ottone cromato. Fornito con flex **TC 1538-M** e con flessibili sottorubinetto **FLX 103821**.

Mixer with pull-out, adjustable flow shower, no-swivel, with anti-scale. Chrome brass body. Supplied with flex **TC 1538-M** and under tap flex **FLX 103821**.

**MD 6551**

**cod. 03.07.05501**

**MD 6552** Con flessibile da 2 m / With 2 m flex

**cod. 03.07.05502**

**MD 61351 – MD 61352 > DOCCIA ESTRAIBILE / PULL OUT SHOWER**

Maniglia / Handle  
KIMMY SERIGRAFATA



D 135

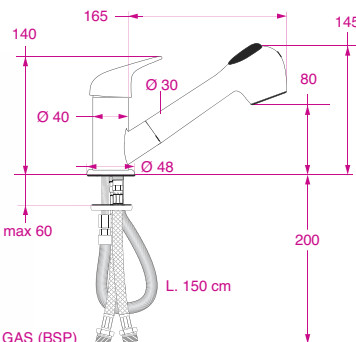

3/8" M GAS (BSP)

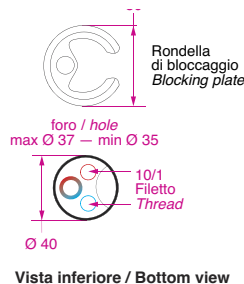

Vista inferiore / Bottom view

Peso / Weight 1,311 Kg

Miscelatore con doccia corta, estraibile a doppio getto, non orientabile, con anticalcare. Corpo in ottone cromato. Fornito con flex **TC 1538-M** e con flessibili sottorubinetto **FLX 103821**.

Mixer with pull-out, adjustable flow shower, no-swivel, with anti-scale. Chrome brass body. Supplied with flex **TC 1538-M** and under tap flex **FLX 103821**.

**MD 61351**

**cod. 03.07.13001**

**MD 61352** Con flessibile da 2 m / With 2 m flex

**cod. 03.07.13002**

Tutte le misure sono espresse in millimetri  
All measurements are in millimeters



# MISCELATORI CERAMICI MONOCOMANDO / ONE HANDLE MIXERS

## MDM 10101 > DOCCIA ESTRAIBILE / PULL OUT SHOWER

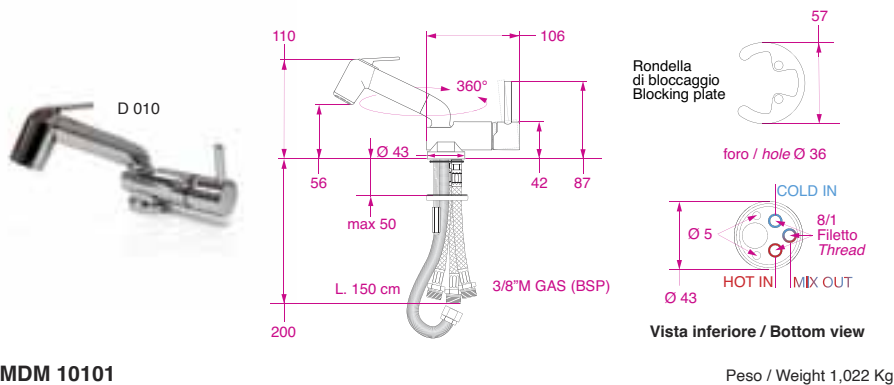

Miscelatore con doccia a levetta, estraibile. Costruito in ottone cromato. Fornito con flex TC 1538 e con flessibili sottorubinetti FLX 813821.

Mixer with pull-out trigger shower. Made in chrome brass. Supplied with flex TC1538 and under tap flex FLX 813821.

MDM 10101

Peso / Weight 1,022 Kg

cod. 03.12.01001



## MA 1600 > ABBATTIBILE / FOLD DOWN

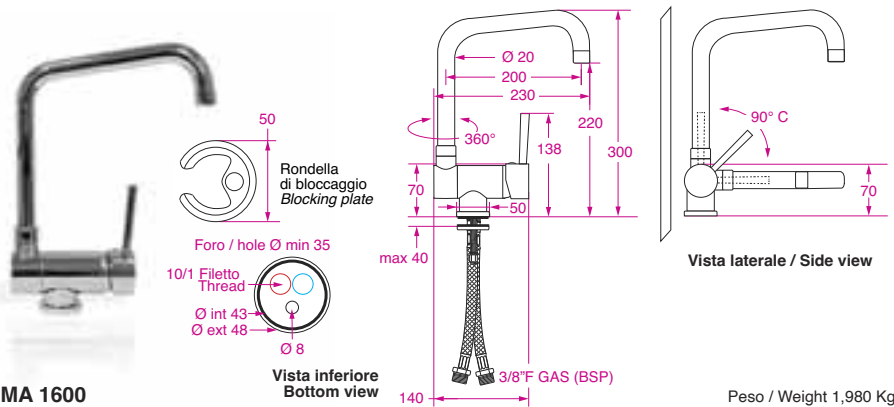

Miscelatore con canna abbattibile e girevole, con aeratore. Costruito in ottone cromato. Fornito con flessibili sottorubinetti FLX 103821.

Mixer with swivel and fold down spout, with aerator. Made in chrome brass. Supplied with under tap flex FLX 103821.

MA 1600

Peso / Weight 1,980 Kg

cod. 03.06.66400

## ML 1100 L > ABBATTIBILE / FOLD DOWN

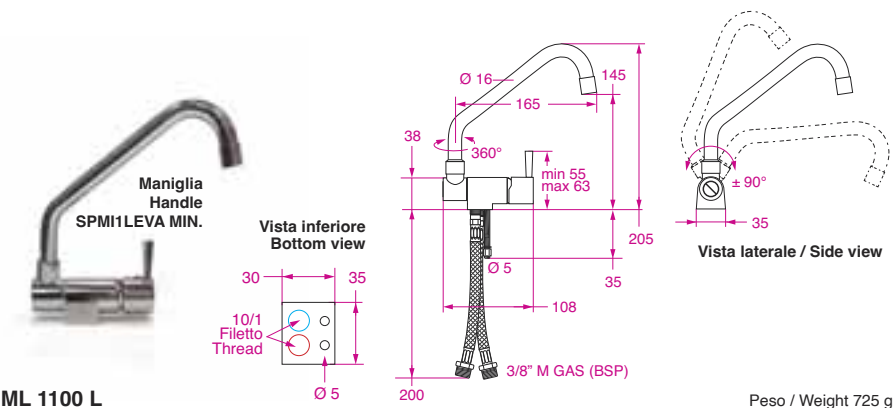

Miscelatore con canna abbattibile e girevole, con aeratore. Costruito in ottone cromato. Fornito con flessibili sottorubinetti FLX 103821.

Mixer with swivel and fold down spout, with aerator. Made in chrome brass. Supplied with under tap flex FLX 103821.

ML 1100 L

Peso / Weight 725 g

cod. 03.23.71900

Tutte le misure sono espresse in millimetri  
All measurements are in millimeters

**ML 2100 L – ML 2110 L > ABBATTIBILE / FOLD DOWN**



Maniglia Handle  
KNB-ML2XX

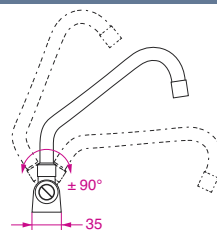
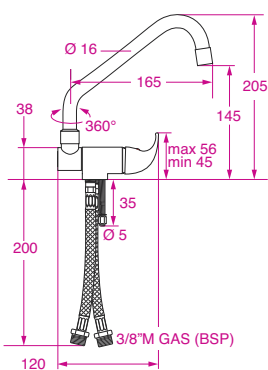
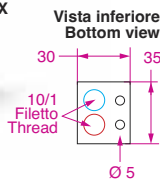

Vista laterale / Side view

Miscelatore con canna abbattibile e girevole, con aeratore.  
Costruito in ottone.  
Fornito con flessibili sottorubinetti **FLX 103821**.

Mixer with swivel and fold down spout, with aerator.  
Made in brass.  
Supplied with under tap flex **FLX 103821**.

**ML 2100 L**

Cromato / Chrome

Peso / Weight 717 g

**cod. 03.23.01900**

**ML 2110 L**

Verniciato bianco / White painted

**cod. 03.23.01910**

**ML 2100 > ABBATTIBILE / FOLD DOWN**



Maniglia Handle  
KNB-ML2XX

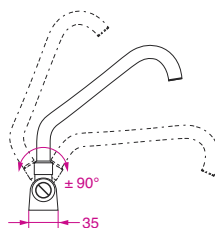
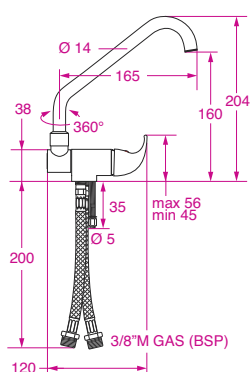
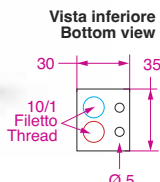

Vista laterale / Side view

Miscelatore con canna abbattibile e girevole, con rompigetto.  
Costruito in ottone cromato.  
Fornito con flessibili sottorubinetti **FLX 103821**.

Mixer with swivel and fold down spout, with flow breaker.  
Made in chrome brass.  
Supplied with under tap flex **FLX 103821**.

**ML 2100**

Peso / Weight 680 g

**cod. 03.23.01000**

**ML 2500 > ABBATTIBILE / FOLD DOWN**



Maniglia Handle  
KNB-ML2XX

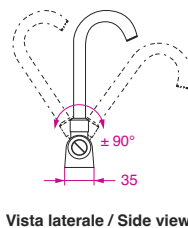
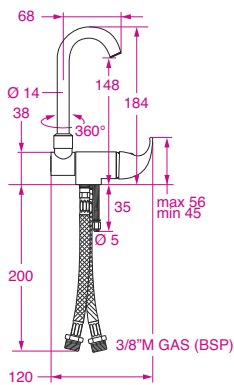
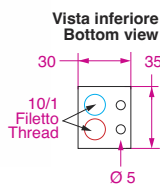

Vista laterale / Side view

Miscelatore con canna abbattibile e girevole, con rompigetto.  
Costruito in ottone cromato.  
Fornito con flessibili sottorubinetti **FLX 103821**.

Mixer with swivel and fold down spout, with flow breaker.  
Made in chrome brass.  
Supplied with under tap flex **FLX 103821**.

**ML 2500**

Peso / Weight 682 g

**cod. 03.23.05000**

**ML 2600 > ABBATTIBILE / FOLD DOWN**



Maniglia Handle  
KNB-ML2XX

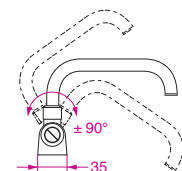
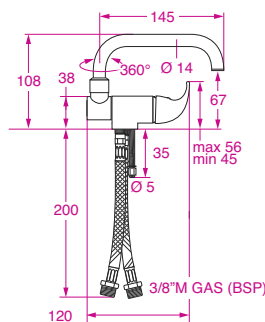
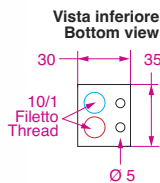

Vista laterale / Side view

Miscelatore con canna abbattibile e girevole, con rompigetto.  
Costruito in ottone cromato.  
Fornito con flessibili sottorubinetti **FLX 103821**.

Mixer with swivel and fold down spout, with flow breaker.  
Made in chrome brass.  
Supplied with under tap flex **FLX 103821**.

**ML 2600**

Peso / Weight 696 g

**cod. 03.23.06000**

Tutte le misure sono espresse in millimetri  
All measurements are in millimeters

# MISCELATORI CERAMICI DOPPIO COMANDO / TWO HANDLE MIXERS

## MR 4100 L > ABBATTIBILE / FOLD DOWN

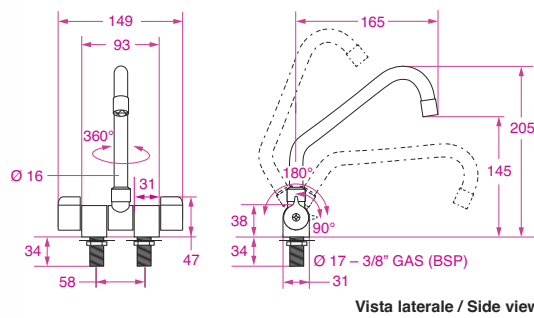

Vista laterale / Side view

Miscelatore con canna abbattibile e girevole, con aeratore. Costruito in ottone cromato.

Mixer with swivel and fold down spout, with aerator. Made in chrome brass.

MR 4100 L

Peso / Weight 898 g

cod. 03.22.12900

## MR 4100 – MR 4110 – MR 4160 – MRK 4100 > ABBATTIBILE / FOLD DOWN

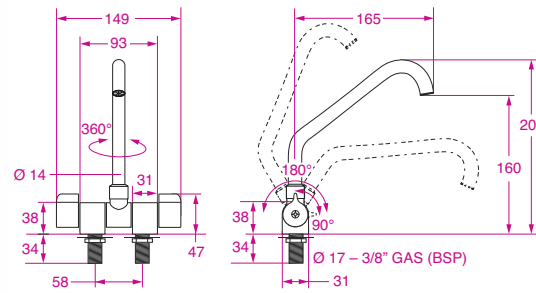

Vista laterale / Side view

Miscelatore con canna abbattibile e girevole, con rompigetto. Costruito in ottone.

Mixer with swivel and fold down spout, with flow breaker. Made in brass.

MR 4100 Cromato / Chrome

cod. 03.22.12000

MR 4110 Verniciato bianco / White painted

cod. 03.22.12010

MR 4160 Cromato spazzolato / Brushed chrome

cod. 03.22.12060

MRK 4100 Verniciato **NERO MAT / BLACK MAT** painted

Peso / Weight 864 g

cod. 03.22.12005

## MR 4500 – MR 4510 – MR 4560 > ABBATTIBILE / FOLD DOWN

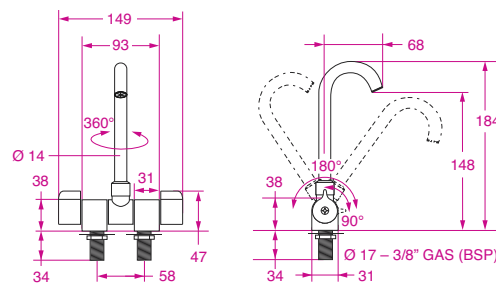

Vista laterale / Side view

Miscelatore con canna abbattibile e girevole, con rompigetto. Costruito in ottone.

Mixer with swivel and fold down spout, with flow breaker. Made in brass.

MR 4500 Cromato / Chrome version

cod. 03.22.15000

MR 4510 Verniciato bianco / White painted

cod. 03.22.15010

MR 4560 Cromato spazzolato / Brushed chrome

Peso / Weight 840 g

cod. 03.22.15060

## MR 4600 – MR 4610 – MR 4660 > ABBATTIBILE / FOLD DOWN

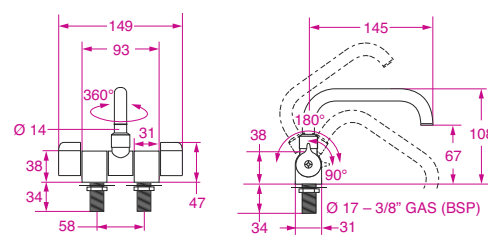

Vista laterale / Side view

Miscelatore con canna abbattibile e girevole, con rompigetto. Costruito in ottone.

Mixer with swivel and fold down spout, with flow breaker. Made in brass.

MR 4600 Cromato / Chrome

cod. 03.22.16000

MR 4610 Verniciato bianco / White painted

cod. 03.22.16010

MR 4660 Cromato spazzolato / Brushed chrome

Peso / Weight 821 g

cod. 03.22.16060

Tutte le misure sono espresse in millimetri  
All measurements are in millimeters

**MG 3100 > TRADIZIONALE / TRADITIONAL**

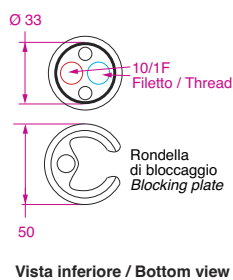
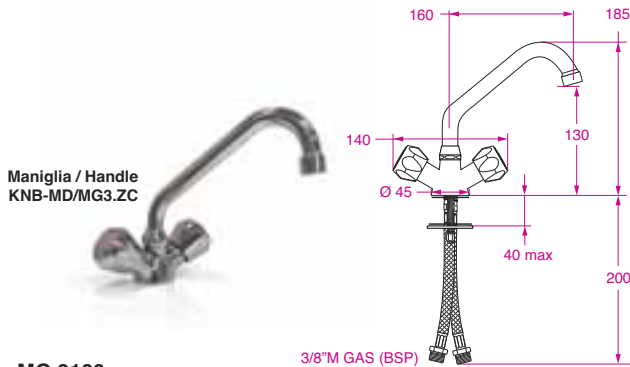

Peso / Weight 837 g

Miscelatore a canna girevole, con aeratore.  
Corpo e canna in ottone cromato.  
Fornito con flessibili sottorubinetti **FLX 103821**.

Mixer with swivel spout, and aerator.  
Chrome brass body and spout.  
Supplied with under tap flex **FLX 103821**.

**cod. 03.01.01000**

**MG 3200 > TRADIZIONALE / TRADITIONAL**

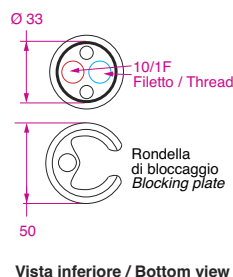
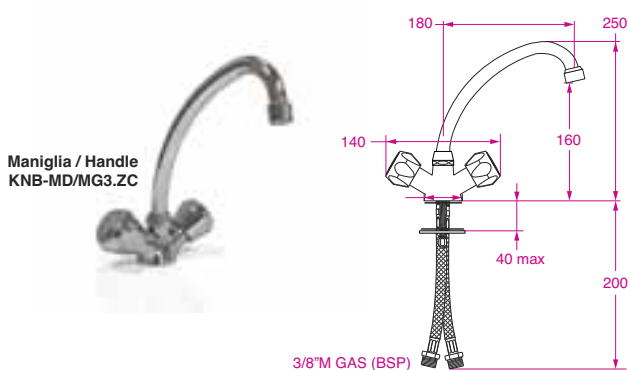

Peso / Weight 970 g

Miscelatore a canna girevole, con aeratore.  
Corpo e canna in ottone cromato.  
Fornito con flessibili sottorubinetti **FLX 103821**.

Mixer with swivel spout, and aerator.  
Chrome brass body and spout.  
Supplied with under tap flex **FLX 103821**.

**cod. 03.01.02000**

**MG 3600 > TRADIZIONALE / TRADITIONAL**

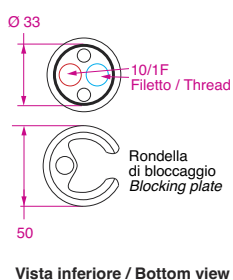
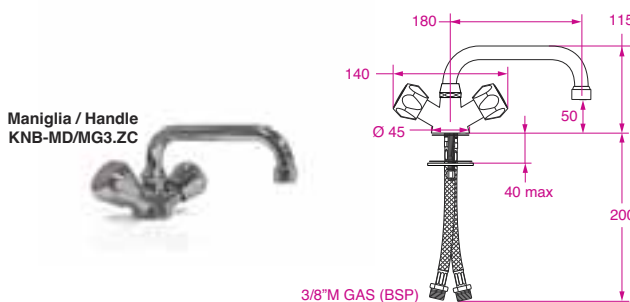

Peso / Weight 946 g

Miscelatore a canna girevole, con aeratore.  
Corpo e canna in ottone cromato.  
Fornito con flessibili sottorubinetti **FLX 103821**.

Mixer with swivel spout, and aerator.  
Chrome brass body and spout.  
Supplied with under tap flex **FLX 103821**.

**cod. 03.01.06000**

**MF 3000 > TRADIZIONALE / TRADITIONAL**

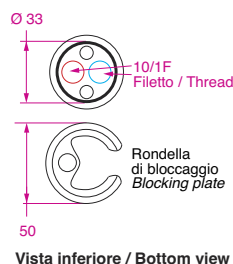
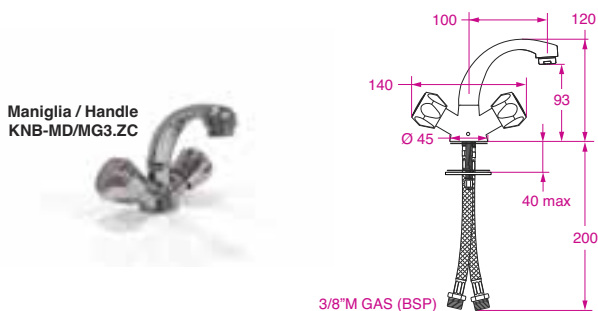

Peso / Weight 1,056 Kg

Miscelatore a canna fissa, con rompigetto.  
Corpo e canna in ottone cromato.  
Fornito con flessibili sottorubinetti **FLX 103821**.

Basin mixer with fixed spout, and flow breaker.  
Chrome brass body and spout.  
Supplied with under tap flex **FLX 103821**.

**cod. 03.02.07000**

Tutte le misure sono espresse in millimetri  
All measurements are in millimeters

# MISCELATORI CERAMICI DOPPIO COMANDO / TWO HANDLE MIXERS

## MD 3111 – MD 3141 > DOCCIA ESTRAIBILE / PULL OUT SHOWER > TRADIZIONALE / TRADITIONAL

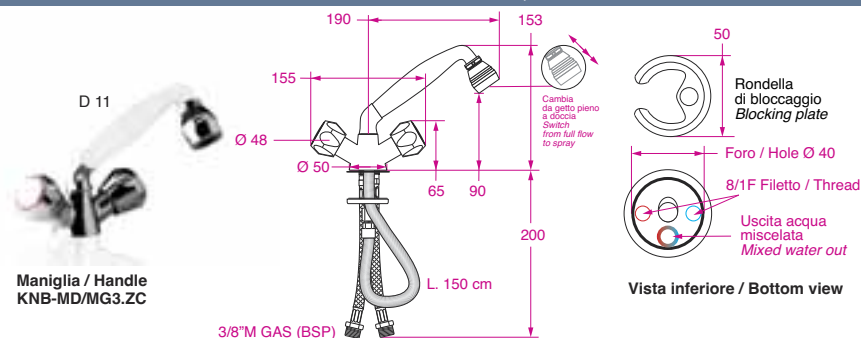

Miscelatore con doccia estraibile, a doppio getto.  
Corpo in ottone cromato.  
Fornito con flex **TC 1538** e con flessibili sottorubinetto **FLX 813821**.

Mixer with swivel, pull-out, adjustable flow shower.  
Chrome brass body.  
Supplied with flex **TC 1538** and under tap flex **FLX 813821**.

<b>MD 3111</b>	Bianca / White		<b>cod. 03.50.01101</b>
<b>MD 3141</b>	Nera / Black	Peso / Weight 1,380 Kg	<b>cod. 03.50.01401</b>

## MD 3911 – MD 3941 > DOCCIA ESTRAIBILE / PULL OUT SHOWER > TRADIZIONALE / TRADITIONAL

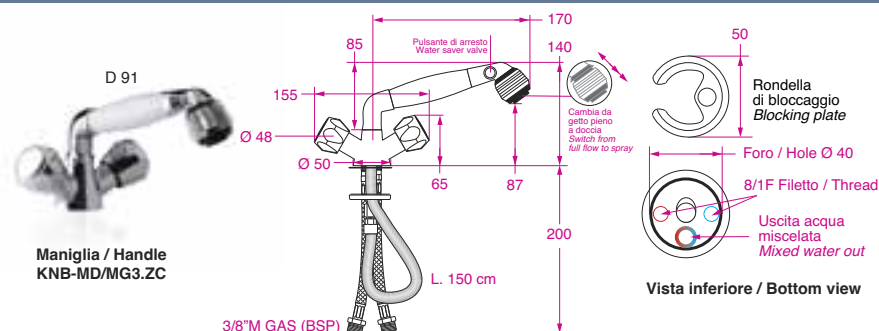

Miscelatore con doccia estraibile, a doppio getto, con pulsante di arresto.  
Corpo in ottone cromato.  
Fornito con flex **TC 1538** e con flessibili sottorubinetto **FLX 813821**.

Mixer with swivel, pull-out, adjustable flow shower, with on-off push button.  
Chrome brass body.  
Supplied with flex **TC 1538** and under tap flex **FLX 813821**.

<b>MD 3911</b>	Bianca / White		<b>cod. 03.50.09101</b>
<b>MD 3941</b>	Nera / Black	Peso / Weight 1,504 Kg	<b>cod. 03.50.09401</b>

## MD 31111 – MD 31141 – MD 31101 > DOCCIA ESTRAIBILE / PULL OUT SHOWER > TRAD.

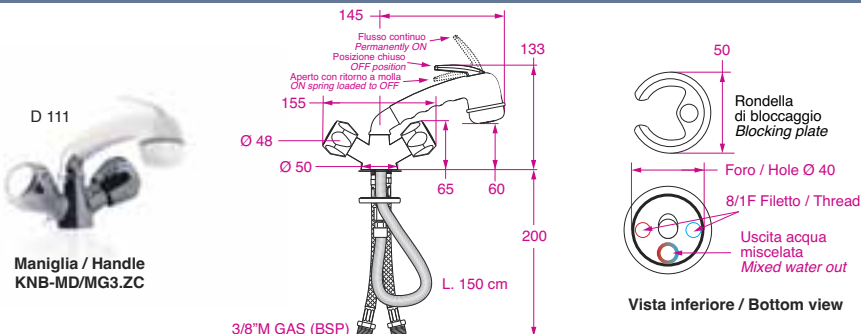

Miscelatore con doccia a levetta, estraibile.  
Corpo in ottone cromato.  
Fornito con flex **TC 1538** e con flessibili sottorubinetto **FLX 813821**.

Mixer with pull-out trigger shower.  
Chrome brass body.  
Supplied with flex **TC1538** and under tap flex **FLX 813821**.

<b>MD 31111</b>	Bianca / White		<b>cod. 03.50.11101</b>
<b>MD 31141</b>	Nera / Black		<b>cod. 03.50.11401</b>
<b>MD 31101</b>	Cromata / Chrome	Peso / Weight 1,358 Kg	<b>cod. 03.50.11001</b>

## MD 3211 – MD 3241 > DOCCIA ESTRAIBILE / PULL OUT SHOWER > TRADIZIONALE / TRADITIONAL

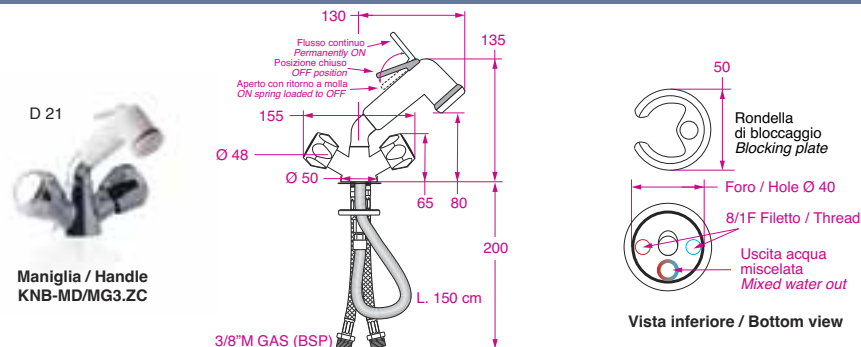

Miscelatore con doccia a levetta, estraibile.  
Corpo in ottone cromato.  
Fornito con flex **TC 1538** e con flessibili sottorubinetto **FLX 813821**.

Mixer with pull-out trigger shower.  
Chrome brass body.  
Supplied with flex **TC1538** and under tap flex **FLX 813821**.

<b>MD 3211</b>	Bianca / White		<b>cod. 03.50.02101</b>
<b>MD 3241</b>	Nera / Black	Peso / Weight 1,360 Kg	<b>cod. 03.50.02401</b>

Tutte le misure sono espresse in millimetri  
All measurements are in millimeters





## MIGNON

### MM 5600 > MIX DOPPIO COMANDO / TWO HANDLE MIXERS > ABBATTIBILE / FOLD DOWN > MIGNON

Maniglia / Handle  
KNB-RG5

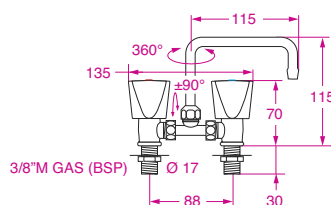

Miscelatore a ponte, con canna girevole e abbattibile. Costruito in ottone cromato. Maniglie triangolari in ABS cromato.

Bridge mixer, with swivel and folding spout. Made in chrome brass. Triangular chrome ABS handles.

MM 5600

Peso / Weight 426 g

cod. 03.48.66000

### MM 5500 > MIX DOPPIO COMANDO / TWO HANDLE MIXERS > ABBATTIBILE / FOLD DOWN > MIGNON

Maniglia / Handle  
KNB-RG5

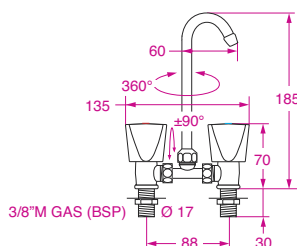

Miscelatore a ponte, con canna girevole e abbattibile. Costruito in ottone cromato. Maniglie triangolari in ABS cromato.

Bridge mixer, with swivel and folding spout. Made in chrome brass. Triangular chrome ABS handles.

MM 5500

Peso / Weight 482 g

cod. 03.48.35000

### RM 5500 > RUBINETTO / TAPS > ABBATTIBILE / FOLD DOWN > MIGNON

Maniglia / Handle  
KNB-RG5

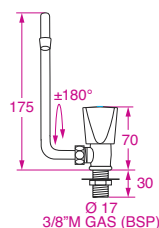

Rubinetto con canna abbattibile. Costruito in ottone cromato. Maniglie triangolari in ABS cromato.

Tap with fold down spout. Made in chrome brass. Triangular chrome ABS handles.

RM 5500 DX  
RM 5500 SX

Peso / Weight 243 g

cod. 03.47.35000

cod. 03.47.35002

Tutte le misure sono espresse in millimetri  
All measurements are in millimeters

# RUBINETTI / TAPS

## RQR 4500 > ABBATTIBILE / FOLD DOWN



Maniglia / Handle  
KNB-RR/MR

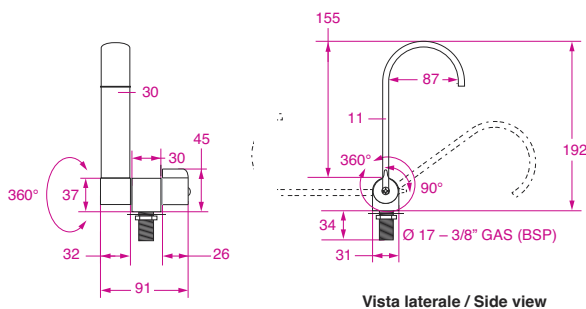

Vista laterale / Side view

Rubinetto con canna girevole e abbattibile, con rompigitto. Costruito in ottone cromato.  
Tap with swivel and fold down spout, with flow breaker. Made in chrome brass.

RQR 4500

Peso / Weight 682 g

cod. 03.21.16063

## RR 4500 – RR 4510 – RR 4560 > ABBATTIBILE / FOLD DOWN



Maniglia  
Handle  
KNB-RR/MR

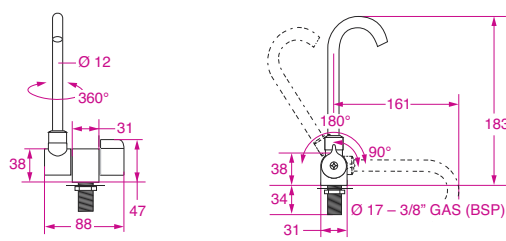

Vista laterale / Side view

Rubinetto con canna girevole e abbattibile, con rompigitto. Costruito in ottone.  
Tap with swivel and fold down spout, with flow breaker. Made in brass.

RR 4500

Cromato / Chrome

Peso / Weight 502 g

cod. 03.21.15000

RR 4510

Smaltato bianco / White coated

cod. 03.21.15010

RR 4560

Cromo spazzolato / Brushed chrome

Ø canna/dia spout 14 mm con/with rompigitto/flow breaker

cod. 03.21.15060

## RR 4600 – RR 4610 – RR 4660 > ABBATTIBILE / FOLD DOWN



Maniglia  
Handle  
KNB-RR/MR

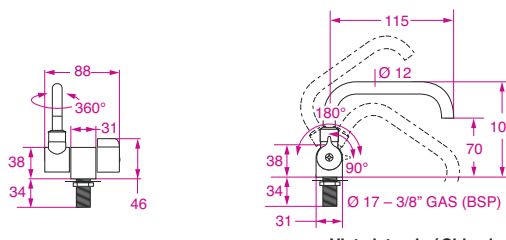

Vista laterale / Side view

Rubinetto con canna girevole e abbattibile, con rompigitto. Costruito in ottone.  
Tap with swivel and fold down spout, with flow breaker. Made in brass.

RR 4600

Cromato / Chrome

Peso / Weight 509 Kg

cod. 03.21.16000

RR 4610

Smaltato bianco / White coated

cod. 03.21.16010

RR 4660

Cromo spazzolato / Brushed chrome

Ø canna/dia spout 14 mm con/with rompigitto/flow breaker

cod. 03.21.16060

## RR 4100 – RR 4110 – RR 4160 > ABBATTIBILE / FOLD DOWN



Maniglia  
Handle  
KNB-RR/MR

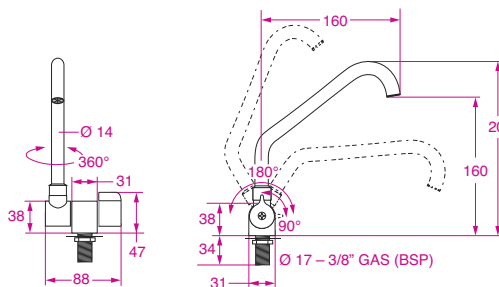

Vista laterale / Side view

Rubinetto con canna girevole e abbattibile, con rompigitto. Costruito in ottone.  
Tap with swivel and fold down spout, with flow breaker. Made in brass.

RR 4100

Cromato / Chrome

cod. 03.21.12000

RR 4110

Smaltato bianco / White coated

cod. 03.21.12010

RR 4160

Cromo spazzolato / Brushed chrome

Peso / Weight 527 Kg

cod. 03.21.12060

Tutte le misure sono espresse in millimetri  
All measurements are in millimeters



**RC 3100** > TRADIZIONALE / TRADITIONAL



Maniglia / Handle  
KNB-ECO  
R/MM/RC/RF

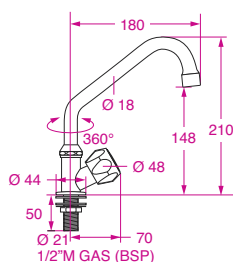

Rubinetto con canna girevole e rompigitto.  
Costruito in ottone cromato.  
Maniglia in ABS cromato.

Tap with swivel spout, and flow breaker.  
Made in chrome brass.  
Chrome ABS handle.

**RC 3100**

Peso / Weight 494 g

**cod. 03.41.01000**

**RC 3200** > TRADIZIONALE / TRADITIONAL



Maniglia / Handle  
KNB-ECO  
R/MM/RC/RF

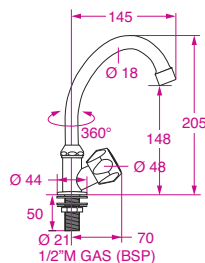

Rubinetto con canna girevole e rompigitto.  
Costruito in ottone cromato.  
Maniglia in ABS cromato.

Tap with swivel spout, and flow breaker.  
Made in chrome brass.  
Chrome ABS handle.

**RC 3200**

Peso / Weight 494 g

**cod. 03.41.02000**

**RF 3000** > TRADIZIONALE / TRADITIONAL

Maniglia / Handle  
KNB-ECO R/MM/RC/RF

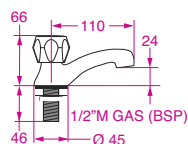

Rubinetto a bocca fissa, con rompigitto.  
Costruito in ottone cromato.  
Maniglia in ABS cromato.

Basin tap with fixed spout, with flow breaker.  
Made in chrome brass.  
Chrome ABS handle.

**RF 3000**

Peso / Weight 412 g

**cod. 03.42.07000**

Tutte le misure sono espresse in millimetri  
All measurements are in millimeters

# RUBINETTI / TAPS

## RD 40101 > DOCCIA ESTRAIBILE / PULL OUT SHOWER

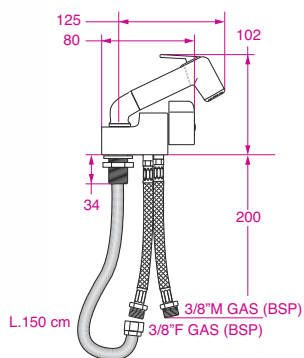

Vista laterale / Side view

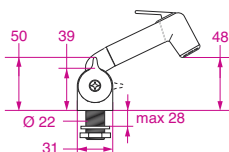

Vista inferiore / Bottom view

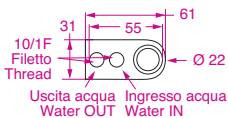

Rubinetto ceramico con doccia a levetta, estraibile. Costruito in ottone cromato. Fornito con flex **TC 1538** e con flessibili sottorubinetto **FLX 103821**.

Ceramic tap with pull-out and trigger shower. Made in chrome brass. Supplied with flex **TC 1538** and under tap flex **FLX 103821**.

RD 40101

Peso / Weight 876 g

cod. 03.19.01001

## RD 4211 PL – RD 4241 PL > DOCCIA ESTRAIBILE / PULL OUT SHOWER

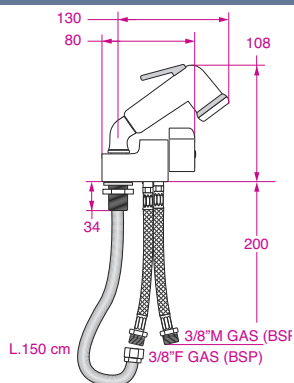

Vista laterale / Side view

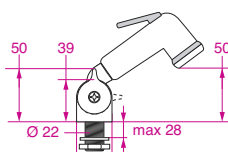

Vista inferiore / Bottom view

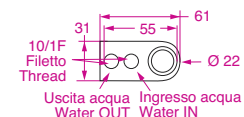

Rubinetto ceramico con doccia a levetta, estraibile. Costruito in ottone cromato. Fornito con flex **TC 1538** e con flessibili sottorubinetto **FLX 103821**.

Ceramic tap with pull-out and trigger shower. Made in chrome brass. Supplied with flex **TC 1538** and under tap flex **FLX 103821**.

RD 4211 PL

Bianca / White

cod. 03.19.02111

RD 4241 PL

Nera / Black

Peso / Weight 900 g

cod. 03.19.02441

## RD 4911 PL – RD 4941 PL > DOCCIA ESTRAIBILE / PULL OUT SHOWER

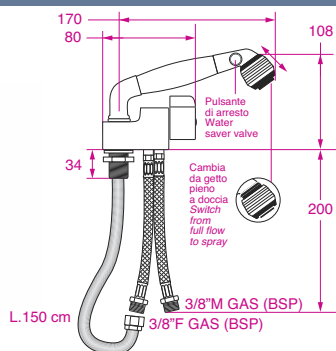

Vista laterale / Side view

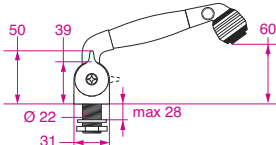

Vista inferiore / Bottom view

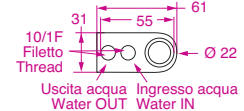

Rubinetto ceramico, con doccia estraibile, a doppio getto, con pulsante di arresto. Costruito in ottone cromato. Fornito con flex **TC 1538** e con flessibili sottorubinetto **FLX 813821**.

Ceramic tap with pull-out shower, water saver and adjustable flow, with ON-OFF push button. Made in chrome brass. Supplied with flex **TC 1538** and under tap flex **FLX 103821**.

RD 4911 PL

Bianca / White

cod. 03.19.09141

RD 4941 PL

Nera / Black

Peso / Weight 1,195 Kg

cod. 03.19.09441



Tutte le misure sono espresse in millimetri  
All measurements are in millimeters

Versione cromata spazzolata  
Brushed chrome version

## BECCUCCI / FAUCETS

### BR 0100 > ABBATTIBILE / FOLD DOWN

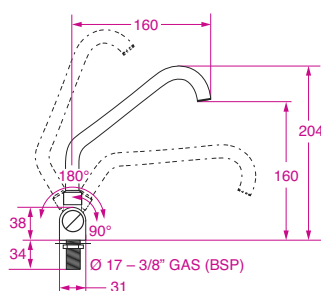
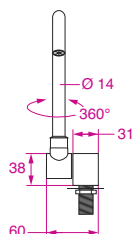

Vista laterale / Side view

Peso / Weight 482 g

Beccuccio con canna Jota, rotante e abbattibile, con rompigitto. Costruito in ottone cromato.

Faucet with swivel, fold down 'J' spout, and flow breaker. Made in chrome brass.

**BR 0100**

**cod. 03.20.01000**

### BR 0500 > ABBATTIBILE / FOLD DOWN

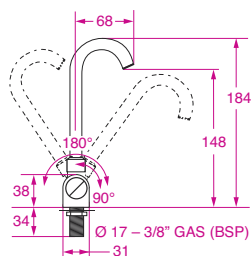
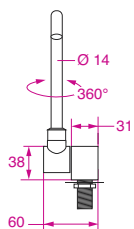

Vista laterale / Side view

Peso / Weight 408 g

Beccuccio con canna alta, rotante e abbattibile, con rompigitto. Costruito in ottone cromato.

Faucet with swivel, fold down tall spout, and flow breaker. Made in chrome brass.

**BR 0500**

**cod. 03.20.05000**

### BR 0600 – BR 0660 > ABBATTIBILE / FOLD DOWN

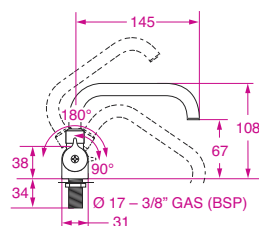
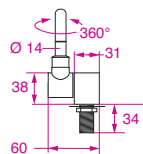

Vista laterale / Side view

Peso / Weight 482 g

Beccuccio con canna bassa, rotante e abbattibile, con rompigitto. Costruito in ottone.

Faucet with swivel, and fold down low spout, and flow breaker. Made in brass.

**BR 0600**

Cromato / Chrome

**cod. 03.20.06000**

**BR 0660**

Cromato spazzolato / Brushed chrome

**cod. 03.20.06060**

Tutte le misure sono espresse in millimetri  
All measurements are in millimeters



# COMANDI DOCCIA / SHOWER CONTROLS

## MI 7000-N > MISCELATORE / MIXER > SOPRA PIANO / COUNTER TOP

Maniglia / Handle  
LEVA 7 BETA

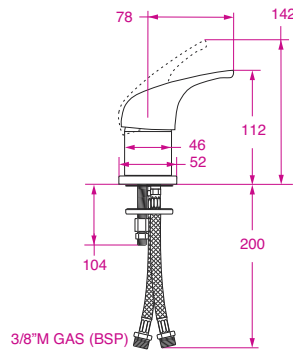

Vista inferiore / Bottom view

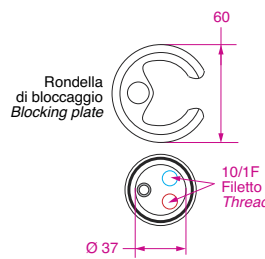

Miscelatore per doccia separata.  
Corpo in ottone cromato.  
Fornito con flessibili  
sottorubinetto  
**FLX 103821.**

Mixer for separate shower.  
Chrome brass body.  
Supplied with under tap flex  
**FLX 103821.**

MI 7000-N

Peso / Weight 660 g

cod. 03.03.10000

## MI 6000-42 > MISCELATORE / MIXER > SOPRA PIANO / COUNTER TOP

Maniglia / Handle  
KIMMY  
SERIGRAFATA

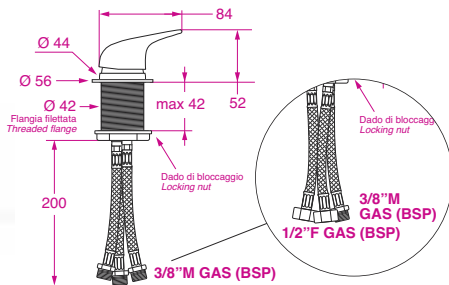

Vista inferiore / Bottom view



Miscelatore per doccia separata.  
Corpo in ottone cromato.  
Fornito con flessibili sottorubinetto.

Mixer for separate shower.  
Chrome brass body.  
Supplied with under tap flex.

MI 1000-42

MI 1000-42-1/2\"F

MI 6000-42

FLX 813821

Peso / Weight 535 g

cod. 03.03.00101

MI 6000-42-1/2\"F

(2x) FLX 811221 + (1x) FLX 813821

cod. 03.03.00102

## MI 6000-N > MISCELATORE / MIXER > SOPRA PIANO / COUNTER TOP

Maniglia / Handle  
KIMMY SERIGRAFATA

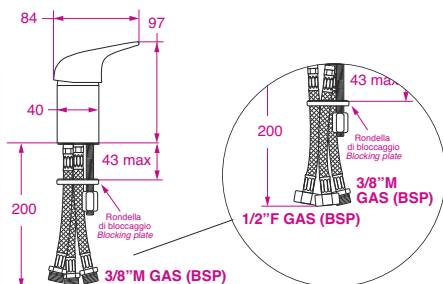

Vista inferiore / Bottom view

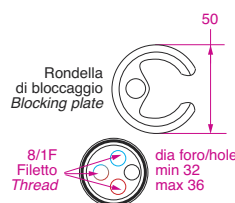

Miscelatore per doccia separata.  
Corpo in ottone cromato.  
Fornito con flessibili sottorubinetto.

Mixer for separate shower.  
Chrome brass body.  
Supplied with under tap flex.

MI 6000-N

MI 6000-N-1/2\"F

MI 6000-N

FLX 813821

Peso / Weight 630 g

cod. 03.03.00000

MI 6000-N-1/2\"F

(2x)FLX 811221 e (1x)FLX 813821

cod. 03.03.00001

## MI 6000-NR > MISCELATORE / MIXER > SOPRA PIANO / COUNTER TOP

Maniglia / Handle  
KIMMY SERIGRAFATA

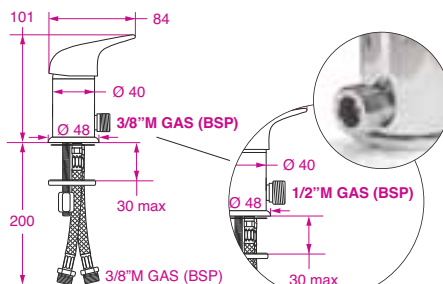

Vista inferiore / Bottom view

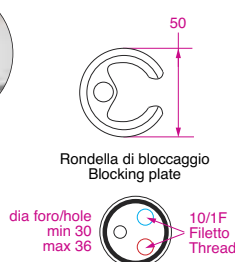

Miscelatore per doccia separata,  
con uscita sopra piano.  
Corpo in ottone cromato.  
Fornito con flessibili  
sottorubinetto **FLX 103821.**

Mixer for separate shower,  
over the counter outlet.  
Chrome brass body.  
Supplied with under tap flex  
**FLX 103821.**

MI 6000-NR38

MI 6000-NR12

MI 6000-NR38 Out 3/8\"M GAS (BSP) – Flex In 3/8\"M GAS (BSP)

Peso / Weight 630 g

cod. 03.03.00010

MI 6000-NR12 Out 1/2\"M GAS (BSP) – Flex In 3/8\"M GAS (BSP)

cod. 03.03.00016

Tutte le misure sono espresse in millimetri  
All measurements are in millimeters



**MI 1000-42 > MISCELATORE / MIXER > SOPRA PIANO / COUNTER TOP**

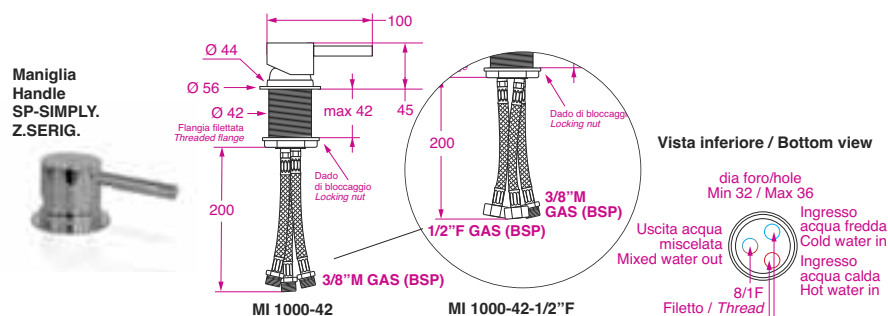

Miscelatore per doccia separata.  
Corpo in ottone cromato.  
Fornito con flessibili sottorubinetto.

Mixer for separate shower.  
Chrome brass body.  
Supplied with under tap flex.

<b>MI 1000-42</b>	<b>FLX 813821</b>	Peso / Weight 535 g	<b>cod. 03.03.00151</b>
<b>MI 1000-42-1/2\"F</b>	<b>(2x) FLX 811221 + (1x) FLX 813821</b>		<b>cod. 03.03.00152</b>

**MI 1000-40 > MISCELATORE / MIXER > SOPRA PIANO / COUNTER TOP**

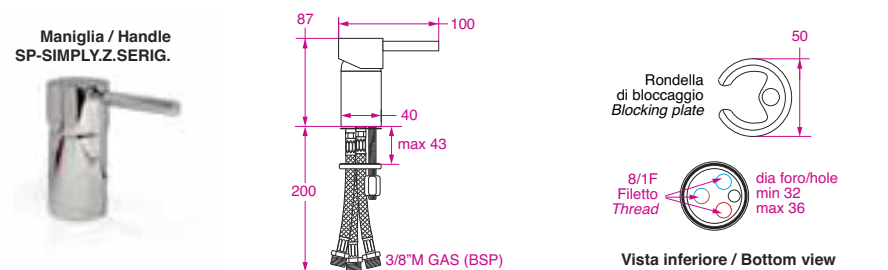

Miscelatore per doccia separata.  
Corpo in ottone cromato.  
Fornito con flessibili sottorubinetto **FLX 813821**.

Mixer for separate shower.  
Chrome brass body.  
Supplied with under tap flex **FLX 813821**.

<b>MI 1000-40</b>		Peso / Weight 640 g	<b>cod. 03.03.00700</b>
-------------------	--	---------------------	-------------------------

**MI 1000-40R > MISCELATORE / MIXER > SOPRA PIANO / COUNTER TOP**

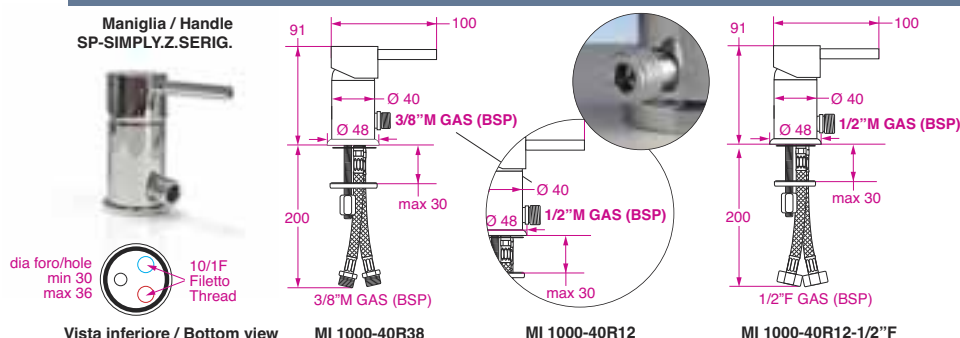

Miscelatore per doccia separata,  
con uscita sopra piano.  
Corpo in ottone cromato.  
Fornito con flessibili sottorubinetto.

Mixer for separate shower,  
over the counter outlet.  
Chrome brass body.  
Supplied with under tap flex.

<b>MI 1000-40R38</b>	Out 3/8\"M GAS (BSP) – Flex In 3/8\"M GAS (BSP) <b>FLX 103821</b>	Peso / Weight 638 g	<b>cod. 03.03.00710</b>
<b>MI 1000-40R12</b>	Out 1/2\"M GAS (BSP) – Flex In 3/8\"M GAS (BSP) <b>FLX 103821</b>		<b>cod. 03.03.00715</b>
<b>MI 1000-40R12-1/2\"F</b>	Out 1/2\"M GAS (BSP) – Flex In 1/2\"F GAS (BSP) <b>FLX 101221</b>		<b>cod. 03.03.00716</b>

Tutte le misure sono espresse in millimetri  
All measurements are in millimeters

# COMANDI DOCCIA / SHOWER CONTROLS

## MI 1000-32 > MISCELATORE / MIXER > SOPRA PIANO / COUNTER TOP

Maniglia / Handle  
SPM11LEVA MIN.

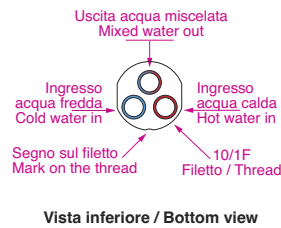
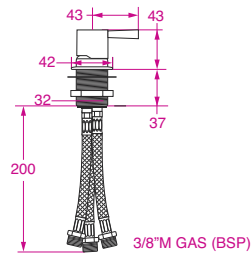

Miscelatore per doccia separata.  
Costruito in ottone cromato.  
Fornito con flessibili  
sottorubinetto **FLX 103821**.

Mixer for separate shower.  
Made in chrome brass.  
Supplied with under tap flex  
**FLX 103821**.

**MI 1000-32**

Peso / Weight 487 g

**cod. 03.26.70000**

## MI 3000/3 - 1/2" F > MISCELATORE / MIXER > SOPRA PIANO / COUNTER TOP

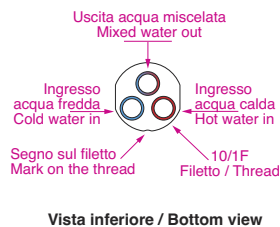
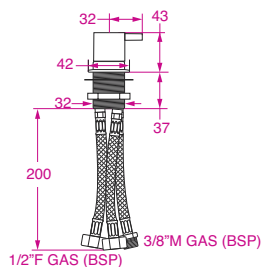

Solo miscelatore  
(senza comando apertura),  
per doccia separata.  
Costruito in ottone cromato.  
Fornito con flessibili sottorubinetto  
(2x)**FLX 101221** e (1x)**FLX 103821**.

Only mixer (without on-off),  
for separate shower.  
Made in chrome brass.  
Supplied with under tap flex  
(2x)**FLX 101221** and (1x)**FLX 103821**.

**MI 3000/3 - 1/2" F**

Peso / Weight 497 g

**cod. 03.26.29001**

## MI 2000/1 - MI 2010 > MISCELATORE / MIXER > SOPRA PIANO / COUNTER TOP

Maniglia / Handle  
KNB-MI2000/1



Maniglia / Handle  
KNB-MI2010

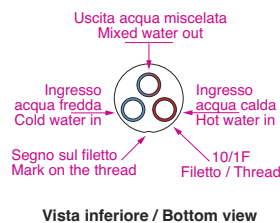
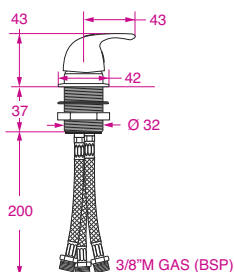

Miscelatore per doccia separata.  
Costruito in ottone.  
Fornito con flessibili  
sottorubinetto **FLX 103821**.

Mixer for separate shower.  
Made in brass.  
Supplied with under tap flex  
**FLX 103821**.

**MI 2000/1**

Cromato / Chrome

Peso / Weight 468 g

**cod. 03.26.10000**

**MI 2010**

Smaltato bianco / White coated

**cod. 03.26.10010**

## MI 3000 > MISCELATORE / MIXER > SOPRA PIANO / COUNTER TOP

Maniglia / Handle  
KNB-FARF-MI3

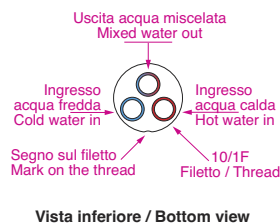
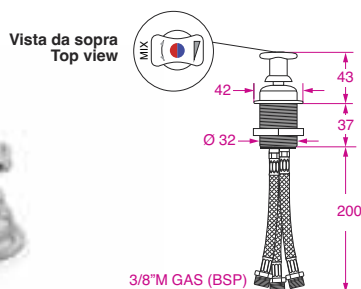

Miscelatore per doccia separata,  
con maniglia a "farfalla".  
Costruito in ottone cromato.  
Fornito con flessibili  
sottorubinetto **FLX 103821**.

Mixer for separate shower,  
"butterfly" handle.  
Made in chrome brass.  
Supplied with under tap flex  
**FLX 103821**.

**MI 3000**

Peso / Weight 343 g

**cod. 03.26.90000**

Tutte le misure sono espresse in millimetri  
All measurements are in millimeters

## Rubinetti di intercettazione / Taps

### RG 3000 > COMANDO DOCCIA / SHOWER CONTROL > TRADIZIONALE / TRADITIONAL

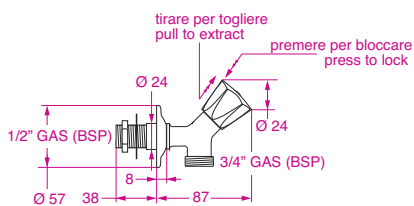

Rubinetto per lavaggio coperta.  
Montaggio a paratia.  
Corpo in ottone cromato.  
Maniglia in ABS cromato.

Deck wash tap.  
Bulkhead mounting.  
Chrome brass body.  
Chrome ABS handle.

RG 3000

Uscita / Outlet 3/4" BSP

Peso / Weight 260 g

cod. 03.45.00000

### RG 5000 > COMANDO DOCCIA / SHOWER CONTROL > TRADIZIONALE / TRADITIONAL

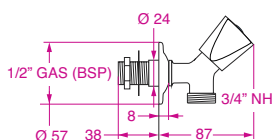

Rubinetto per lavaggio coperta.  
**Con raccordo di uscita 3/4" NH  
adatta al mercato USA**  
Montaggio a paratia.  
Corpo in ottone cromato.  
Maniglia in ABS cromato.

Deck wash tap.  
**Outlet adaptor 3/4" NH  
suitable for the  
USA market version**  
Bulkhead mounting.  
Chrome brass body.  
Chrome ABS handle.

RG 5000

Uscita / Outlet 3/4" NH

Peso / Weight 265 g

cod. 03.45.30000

### RI 2000 > COMANDO DOCCIA / SHOWER CONTROL

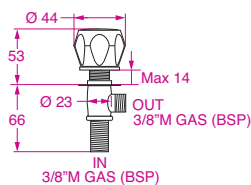

Rubinetto per doccia separata,  
con raccordi sotto piano.  
Corpo in ottone cromato.  
Maniglia in ABS cromato.

Tap for separate shower,  
inlet and outlet under the counter.  
Chrome brass body.  
Chrome ABS handle..

RI 2000

Peso / Weight 237 g

cod. 03.25.00000

### RI 3000 > COMANDO DOCCIA / SHOWER CONTROL

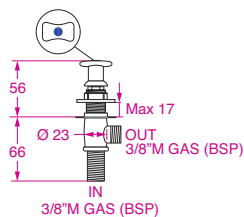

Rubinetto per doccia separata,  
con raccordi sotto piano.  
Costruito in ottone cromato.

Tap for separate shower,  
inlet and outlet under the counter.  
Made in chrome brass.

RI 3000

Peso / Weight 250 g

cod. 03.25.90000

Tutte le misure sono espresse in millimetri  
All measurements are in millimeters

# COMANDI DOCCIA / SHOWER CONTROLS

## ML 1000 > MIX MONOCOMANDO / ONE HANDLE MIXER > PER ABBATTIBILE / FOR FOLD DOWN

Maniglia / Handle  
SPM11LEVA MIN.

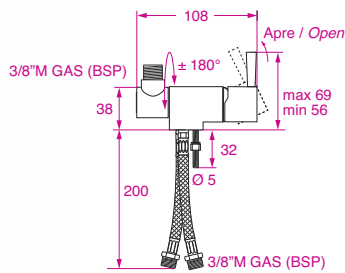

Vista laterale / Side view

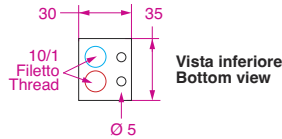

Miscelatore per doccia separata, con uscita sopra piano. Costruito in ottone cromato. Fornito con flessibili sottorubinetti **FLX 103821**.

Mixer for separate shower, over the counter outlet. Made in chrome brass. Supplied with under tap flex **FLX 103821**.

ML 1000

Peso / Weight 620 g

cod. 03.23.70000

## ML 2000 > MIX MONOCOMANDO / ONE HANDLE MIXER > PER ABBATTIBILE / FOR FOLD DOWN

Maniglia / Handle  
KNB-ML2XX

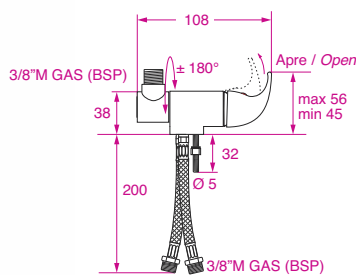

Vista laterale / Side view

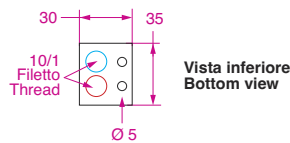

Miscelatore per doccia separata, con uscita sopra piano. Costruito in ottone cromato. Fornito con flessibili sottorubinetti **FLX 103821**.

Mixer for separate shower, over the counter outlet. Made in chrome brass. Supplied with under tap flex **FLX 103821**.

ML 2000

Peso / Weight 620 g

cod. 03.23.00000

## MR 4000 > MIX DOPPIO COMANDO / DOUBLE HANDLE MIXER > PER ABBATTIBILE / FOR FOLD DOWN

Maniglia / Handle  
KNB-RR/MR

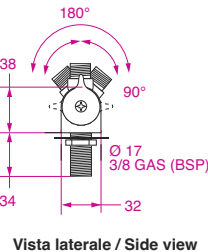
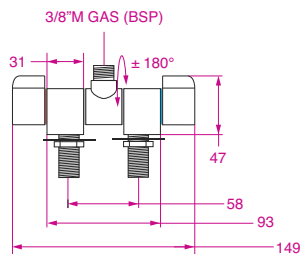

Miscelatore per doccia separata, con uscita sopra piano. Costruito in ottone cromato. Con vitone ceramico.

Mixer for separate shower, over the counter outlet. Made in chrome brass. With ceramic valve.

MR 4000

Peso / Weight 784 g

cod. 03.22.10000

## RR 4000 > RUBINETTO / TAP > PER ABBATTIBILE / FOR FOLD DOWN

Maniglia / Handle  
KNB-RR/MR

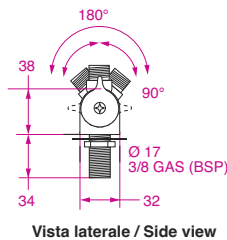
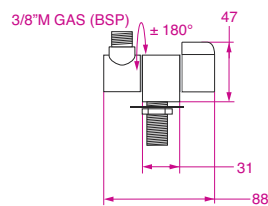

Rubinetto per doccia separata, con uscita sopra piano. Costruito in ottone cromato. Con vitone ceramico.

Tap for separate shower, over the counter outlet. Made in chrome brass. With ceramic valve.

RR 4000

Peso / Weight 441 g

cod. 03.21.10000

Tutte le misure sono espresse in millimetri  
All measurements are in millimeters





**MM 3000** > MIX DOPPIO COMANDO / DOUBLE HANDLE MIXER > PER ABBATTIBILE / FOR FOLD DOWN  
MIGNON

Maniglia / Handle KNB-ECO RI/MM/RC/RF

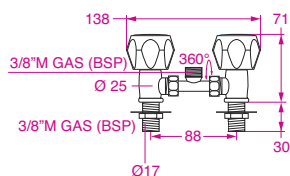

Miscelatore per doccia separata, con uscita sopra piano. Corpo in ottone cromato. Maniglia in ABS cromato.

Mixer for separate shower, over the counter outlet. Chrome brass body. Chrome ABS handle.

**MM 3000**

Peso / Weight 410 g

**cod. 03.48.00000**

**MM 5000** > MIX DOPPIO COMANDO / DOUBLE HANDLE MIXER > PER ABBATTIBILE / FOR FOLD DOWN  
MIGNON

Maniglia / Handle KNB-RG3000

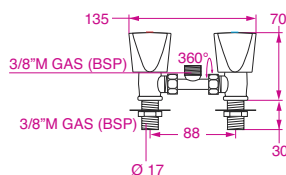

Miscelatore per doccia separata, con uscita sopra piano. Corpo in ottone cromato. Maniglia in ABS cromato.

Mixer for separate shower, over the counter outlet. Chrome brass body. Chrome ABS handle.

**MM 5000**

Peso / Weight 429 g

**cod. 03.48.30000**

Tutte le misure sono espresse in millimetri  
All measurements are in millimeters

# COMANDI DOCCIA / SHOWER CONTROLS

## MRDI 1000 > A PARATIA / BULKHEAD MOUNTING

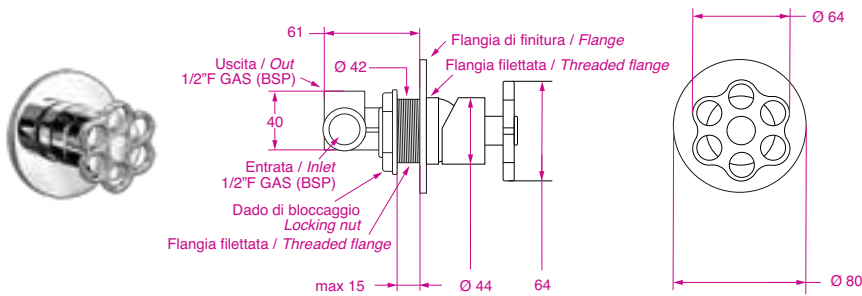

Miscelatore a paratia, montaggio ad incasso. Costruito in ottone.  
Bulkhead shower mixer, for inset mounting. Made in brass.

<b>MRDI 1000</b>	Cromato / Chrome		<b>cod. 03.04.63012</b>
<b>MRDI 1000 K</b>	Ottone NERO MAT / Made in BLACK MAT brass	Peso / Weight 0,820 Kg	<b>cod. 03.04.63014</b>

## MJADI 1000 > A PARATIA / BULKHEAD MOUNTING

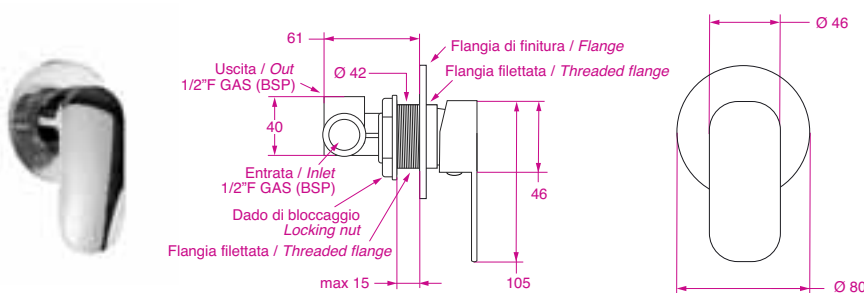

Miscelatore a paratia, montaggio ad incasso. Costruito in ottone.  
Bulkhead shower mixer, for inset mounting. Made in brass.

<b>MJADI 1000</b>	Cromato / Chrome		<b>cod. 03.04.63000</b>
<b>MJADI 1000 K</b>	Ottone NERO MAT / Made in BLACK MAT brass	Peso / Weight 0,710 Kg	<b>cod. 03.04.63002</b>

## MKYDI 1000 > A PARATIA / BULKHEAD MOUNTING

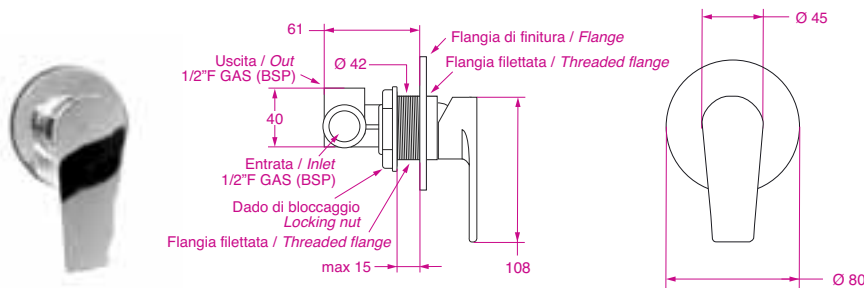

Miscelatore a paratia, montaggio ad incasso. Costruito in ottone.  
Bulkhead shower mixer, for inset mounting. Made in brass.

<b>MKYDI 1000</b>	Cromato / Chrome		<b>cod. 03.04.63008</b>
<b>MKYDI 1000 K</b>	Ottone NERO MAT / Made in brass BLACK MAT	Peso / Weight 0,770 Kg	<b>cod. 03.04.63010</b>

## MJODI 1000 > A PARATIA / BULKHEAD MOUNTING

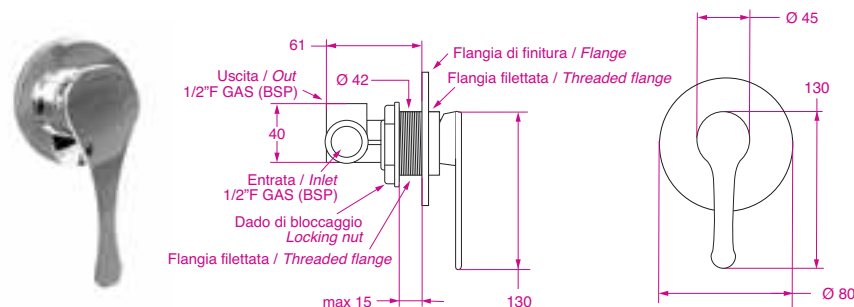

Miscelatore a paratia, montaggio ad incasso. Costruito in ottone.  
Bulkhead shower mixer, for inset mounting. Made in brass.

<b>MJODI 1000</b>	Cromato / Chrome		<b>cod. 03.04.63004</b>
<b>MJODI 1000 K</b>	Ottone NERO MAT / Made in brass BLACK MAT	Peso / Weight 0,751 Kg	<b>cod. 03.04.63006</b>

Tutte le misure sono espresse in millimetri  
All measurements are in millimeters

## MQDI 1000 > A PARATIA / BULKHEAD MOUNTING

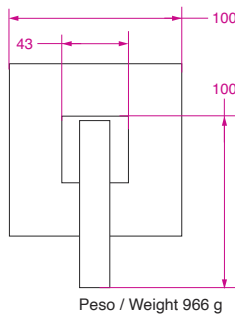
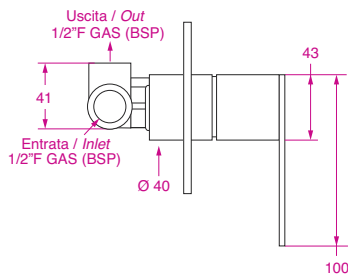

**MQDI 1000**

Peso / Weight 966 g

**cod. 03.04.60000**

Miscelatore a paratia,  
montaggio ad incasso.  
Costruito in ottone cromato.

Bulkhead shower mixer,  
for inset mounting.  
Made in chrome brass.

## MDI 1000 > A PARATIA / BULKHEAD MOUNTING

Maniglia / Handle  
SP-SIMPLY.Z.MDI.SER

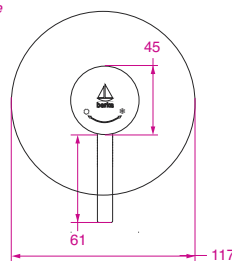
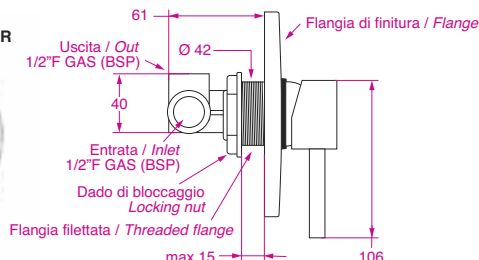

**MDI 1000**

Peso / Weight 743 g

**cod. 03.04.00700**

**MDI 1000-N** Senza rosone / No front plate

Peso / Weight 740 g

**cod. 03.04.00800**

Miscelatore a paratia,  
montaggio ad incasso.  
Corpo in ottone cromato.

Bulkhead shower mixer,  
for inset mounting.  
Chrome brass body.

## MDI 6000 > A PARATIA / BULKHEAD MOUNTING

Maniglia / Handle  
KIMMY SERIGRAFATA

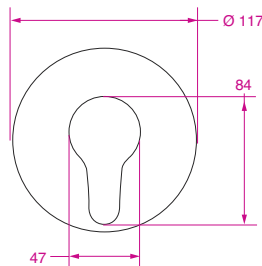
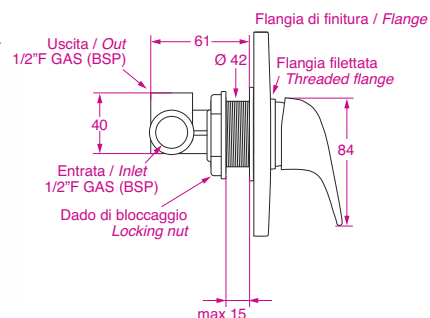

**MDI 6000**

Peso / Weight 728 g

**cod. 03.04.00600**

**MDI 6000-N** Senza rosone / No front plate

Peso / Weight 662 g

**cod. 03.04.00000**

Miscelatore a paratia,  
montaggio ad incasso.  
Corpo in ottone cromato.

Bulkhead shower mixer,  
for inset mounting.  
Chrome brass body.

## MDI 7000 > A PARATIA / BULKHEAD MOUNTING

Maniglia / Handle  
LEVA 7 BETA

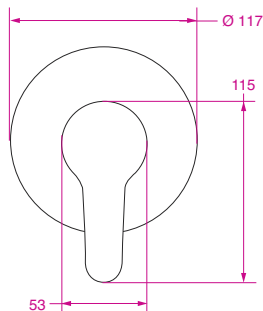
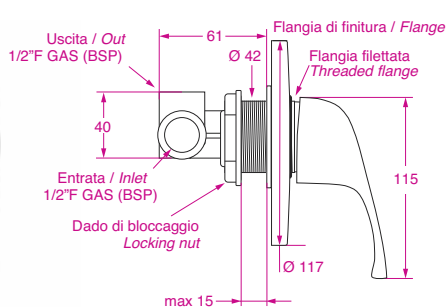

**MDI 7000**

Peso / Weight 730 g

**cod. 03.04.10000**

Miscelatore a paratia,  
montaggio ad incasso.  
Corpo in ottone cromato.

Bulkhead shower mixer,  
for inset mounting.  
Body in chrome brass.

## MDI 8000 > A PARATIA / BULKHEAD MOUNTING

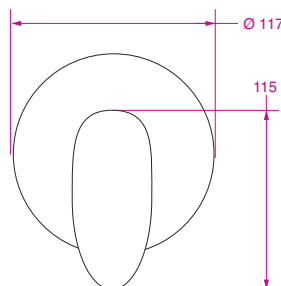
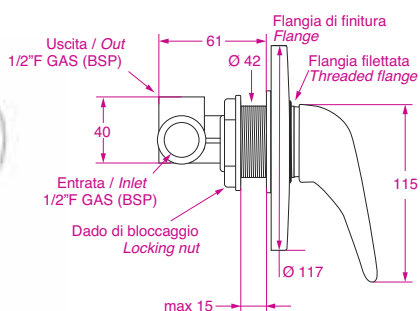

**MDI 8000**

Peso / Weight 760 g

**cod. 03.04.20000**

Miscelatore a paratia,  
montaggio ad incasso.  
Corpo in ottone cromato.

Bulkhead shower mixer,  
for inset mounting.  
Chrome brass body.

Tutte le misure sono espresse in millimetri  
All measurements are in millimeters

## CONTENITORE AD INCASSO / RECESSED CONTAINER

### MR 2010 – MR 2040 > COMANDO DOCCIA / SHOWER CONTROL > MISCELATORE / MIXER

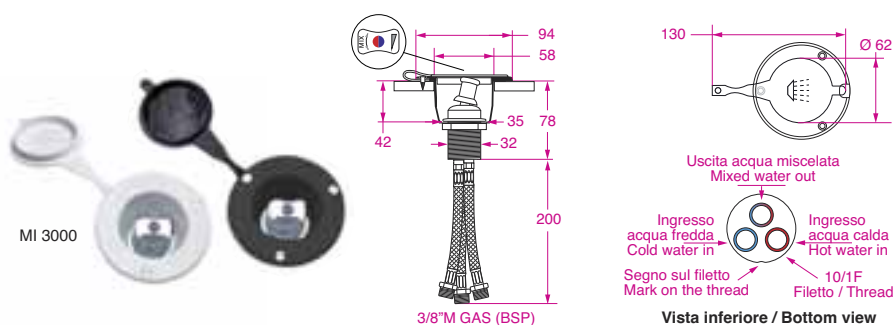

Miscelatore compatto, con contenitore ad incasso (R81/1 - R84/1) e coperchio (C81 - C84). Fornito con flessibili sottorubinetti FLX 103821.

Compact mixer, with recessed container (R81/1 - R84/1) and cover (C81 - C84). Supplied with under tap flex FLX 103821.

MR 2010	Bianco / White		<b>cod. 03.26.90110</b>
MR 2040	Nero / Black	Peso / Weight 468 g	<b>cod. 03.26.90440</b>

### RR 3010 – RR 3040 > COMANDO DOCCIA / SHOWER CONTROL > RUBINETTO / TAP

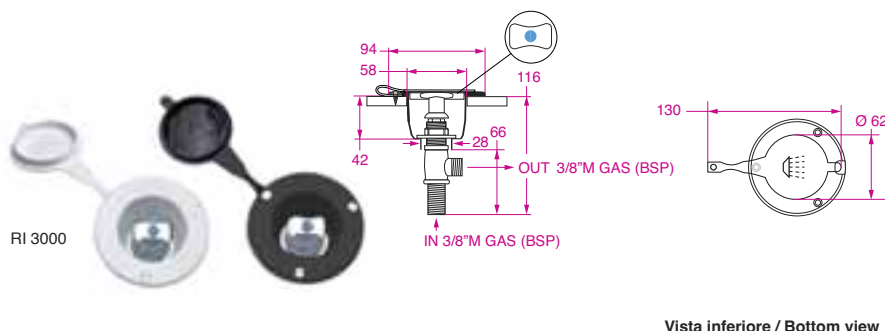

Rubinetto compatto, con contenitore ad incasso (R81/1 - R84/1) e coperchio (C81 - C84).

Compact tap, with recessed container (R81/1 - R84/1) and cover (C81 - C84).

RR 3010	Bianco / White		<b>cod. 03.25.90110</b>
RR 3040	Nero / Black	Peso / Weight 291 g	<b>cod. 03.25.90440</b>

### DR 1543 – DR 1513 > DOCCIA / SHOWER > DA POZZETTO / COCKPIT



Docce a pulsante, con contenitore ad incasso (R81/1 - R84/1) e coperchio (C81 - C84). Fornito con tubo .

On-off push button shower with recessed container (R81/1 - R84/1) and cover (C81 - C84). Supplied with hose.

DR 1543	Nera / Black	Tubo/Hose TP 2038-C/4	<b>cod. 03.66.15442</b>
DR 1513	Bianca / White	Tubo/Hose TP 2038-C/1	Peso / Weight 517 g <b>cod. 03.66.15112</b>

### CONTENITORI E COPERCHI DI RICAMBIO AD INCASSO / RECESSED CONTAINER AND COVER CUP

R81 - R84

R81/1 - R84/1

C81 - C84



R 81	Bianco / White	<b>cod. 03.85.40010</b>	R 81/1	Bianco / White	<b>cod. 03.85.40011</b>	C 81	Bianco / White	<b>cod. 03.85.41010</b>
R 84	Nero / Black	<b>cod. 03.85.40040</b>	R 84/1	Nero / Black	<b>cod. 03.85.40041</b>	C 84	Nero / Black	<b>cod. 03.85.41040</b>

Tutte le misure sono espresse in millimetri  
All measurements are in millimeters



## MISCELATORI TERMOSTATICI / THERMOSTATIC MIXERS

### MT 9000 L

Tipo leggero / Light type

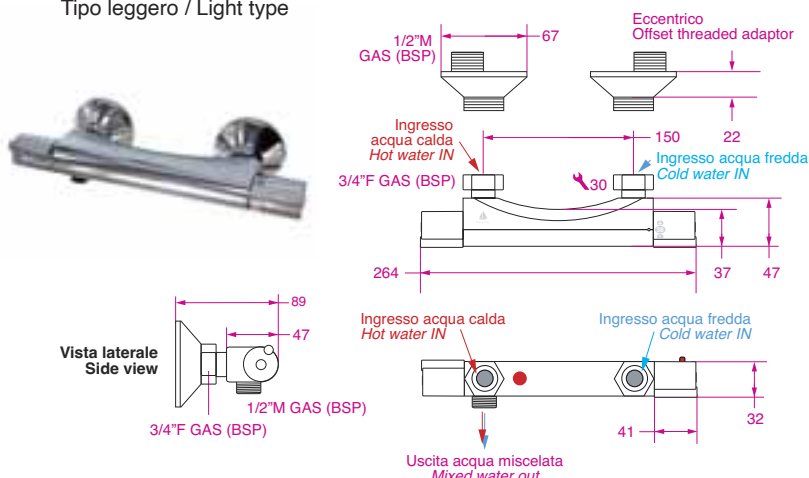

Miscelatore termostatico tipo leggero. Manopola di regolazione della temperatura con pulsante di blocco a 38°C. Corpo in ottone cromato, maniglie in ABS cromato. Montaggio a paratia, con prolunghe opzionali.

Thermostatic mixer light type. Temperature control with locking button at 38°C. Chrome brass body, chrome ABS handles. Mounting on bulkead, with optional extensions.

#### 2 Eccentrici inclusi 2 Offset threaded adaptors included

Peso  
Weight  
120 g  
Coppia/Pair

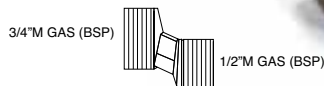

Miscelatore termostatico tipo pesante. Manopola di regolazione della temperatura con pulsante di blocco a 38°C. Corpo in ottone cromato, maniglie in ABS cromato. Montaggio a paratia, con prolunghe opzionali.

Thermostatic mixer heavy type. Temperature control with locking button at 38°C. Chrome brass body, chrome ABS handles. Mounting on bulkead, with optional extensions.

### MT 9000 L

Peso / Weight 1,265 Kg

cod. 03.04.90000

### MT 9000 H

Tipo pesante / Heavy type

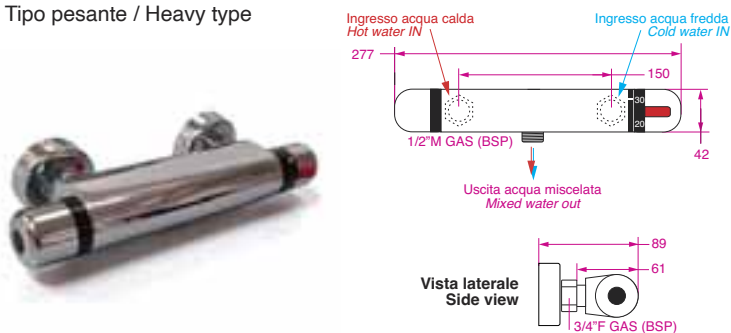

### MT 9000 H

Peso / Weight 1,830 Kg

cod. 03.04.90100

### PP 9000

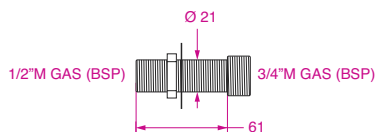

Prolunghe per fissaggio a paratia. Facilitano il montaggio dei miscelatori termostatici a bordo di barche e camper. Costruiti in ottone con rondella inox.

Extensions for bulkhead mounting. Facilitate the installation of thermostatic mixers on board of yachts and camper vans. Made in brass with s/s washer.

### PP 9000

Peso / Weight 28 g

cod. 03.04.90199

Tutte le misure sono espresse in millimetri  
All measurements are in millimeters



## KIT DOCCE DA PIANO / SHOWERS KIT

### DS 1513 – DS 1543 > DA POZZETTO / COCKPIT



D 151

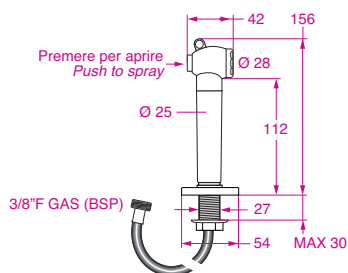

Doccia a pulsante,  
con supporto **S30**.  
Push button shower,  
with support **S30**.

<b>DS 1513</b>	Bianca / White	Flex TP 2038-C/1		<b>cod. 03.62.15112</b>
<b>DS 1543</b>	Nera / Black	Flex TP 2038-C/4	Peso / Weight 500 g	<b>cod. 03.62.15442</b>

### DS 1003 – DS 1013 > DA POZZETTO / COCKPIT

D 101

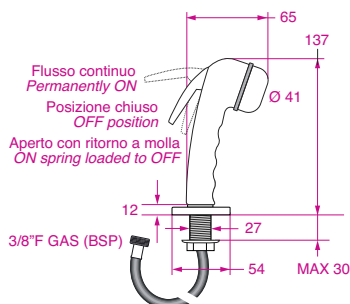

Doccia a levetta,  
con supporto **S30**.  
Trigger shower,  
with support **S30**.

<b>DS 1003</b>	Cromata / Chrome	Flex TP 2038-C/00		<b>cod. 03.62.10012</b>
<b>DS 1013</b>	Bianca / White	Flex TP 2038-C/1	Peso / Weight 373 g	<b>cod. 03.62.10112</b>

### DS 0313 - DS 0343 > DA POZZETTO / COCKPIT



D 31

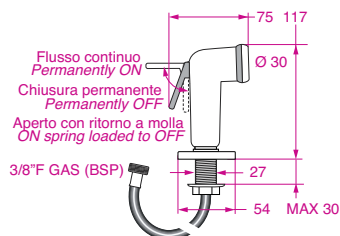

Doccia a levetta,  
con supporto **S30**.  
Trigger shower,  
with support **S30**.

<b>DS 0313</b>	Bianca / White	Flex TP 2038-C/1		<b>cod. 03.62.03112</b>
<b>DS 0343</b>	Nera / Black	Flex TP 2038-C/4	Peso / Weight 376 g	<b>cod. 03.62.03442</b>

### DS 0211 – DS 0241 > DA LAVABO / BASIN

D 21

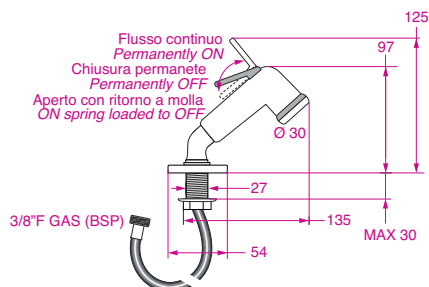

Doccia a levetta,  
con supporto **S10**.  
Trigger shower,  
with support **S10**.

<b>DS 0211</b>	Bianca / White	Flex TC 1538		<b>cod. 03.62.02101</b>
<b>DS 0241</b>	Nera / Black	Flex TC 1538	Peso / Weight 435 g	<b>cod. 03.62.02401</b>

Tutte le misure sono espresse in millimetri  
All measurements are in millimeters

Composizioni disponibili con flessibili di varie lunghezze  
Showers kit available in different flex lengths

## IMPUGNATURE DOCCE / SHOWERS HANDLES

### D 150 - D 151 - D 154

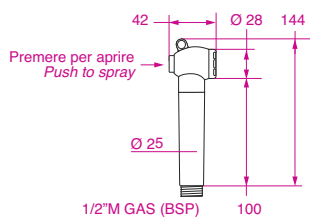

Doccia a pulsante.  
Testa in ottone cromato,  
impugnatura in ABS.

Push button shower.  
Chrome brass head,  
ABS shower handle.

D 150	Cromata / Chrome		<b>cod. 03.60.15000</b>
D 151	Bianca / White		<b>cod. 03.60.15100</b>
D 154	Nera / Black	Peso / Weight 220 g	<b>cod. 03.60.15400</b>

### D 100 - D 101 - D 104

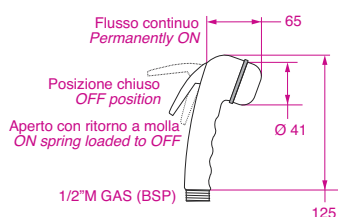

Doccia a levetta da pozzetto  
Impugnatura in ABS.

Trigger cockpit shower.  
ABS shower handle.

D 100	Cromata / Chrome		<b>cod. 03.60.10000</b>
D 101	Bianca / White		<b>cod. 03.60.10100</b>
D 104	Nera / Black	Peso / Weight 82 g	<b>cod. 03.60.10400</b>

### D 31 - D 34

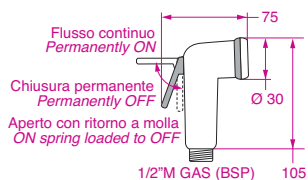

Doccia a levetta da pozzetto  
Impugnatura in ABS.

Trigger cockpit shower.  
ABS shower handle.

D 31	Bianca / White		<b>cod. 03.60.03100</b>
D 34	Nera / Black	Peso / Weight 81 g	<b>cod. 03.60.03400</b>

### D 21 - D 24

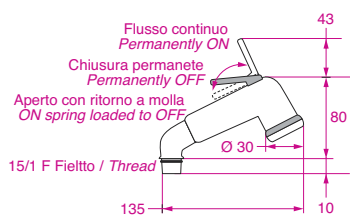

Doccia a levetta  
con gomito in ottone cromato  
e impugnatura in ABS.

Trigger shower handle  
with chrome brass elbow  
and ABS shower handle.

D 21	Bianca / White		<b>cod. 03.60.02100</b>
D 24	Nera / Black	Peso / Weight 171 g	<b>cod. 03.60.02400</b>

Tutte le misure sono espresse in millimetri  
All measurements are in millimeters

# KIT DOCCE DA PIANO / SHOWERS KIT

## DS 0111 – DS 0141 > DA LAVABO / BASIN

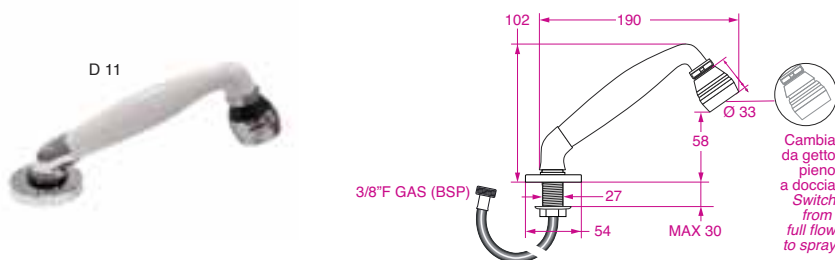

Doccia a doppio getto,  
con supporto **S10**.  
Adjustable flow, elbow shower,  
with support **S10**.

<b>DS 0111</b>	Bianca / White	Flex TC 1538		<b>cod. 03.62.01101</b>
<b>DS 0141</b>	Nera / Black	Flex TC 1538	Peso / Weight 455 g	<b>cod. 03.62.01401</b>

## DS 1101 – DS 1113 > DA LAVABO / BASIN

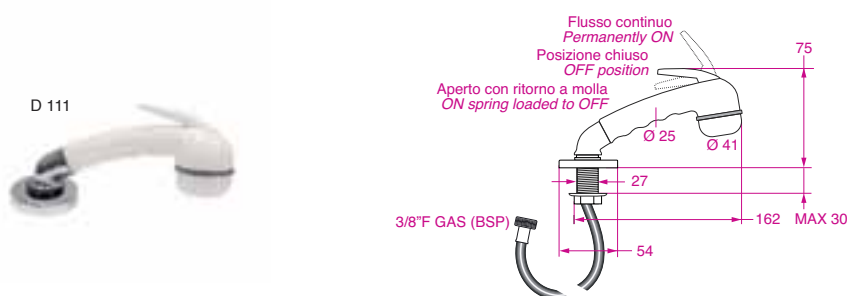

Doccia a levetta,  
con supporto **S10**.  
Trigger shower,  
with support **S10**.

<b>DS 1101</b>	Cromata / Chrome	Flex TC 1538		<b>cod. 03.62.11001</b>
<b>DS 1113</b>	Bianca / White	Flex TP 2038/1	Peso / Weight 424 g	<b>cod. 03.62.11112</b>

## DS 0911 – DS 0941 > DA LAVABO / BASIN

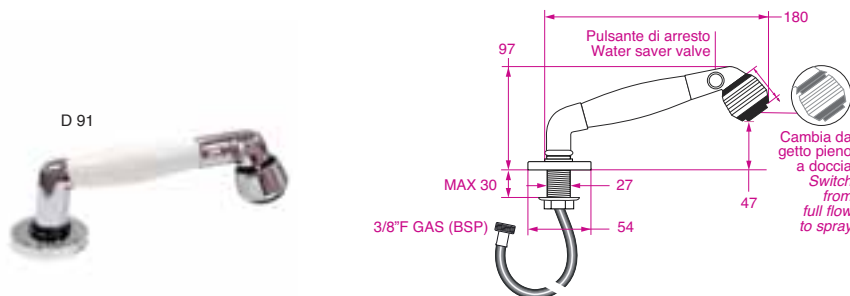

Doccia a doppio getto,  
con pulsante di arresto,  
con supporto **S10**.  
Adjustable flow, elbow shower,  
with water saver valve,  
with support **S10**.

<b>DS 0911</b>	Bianca / White	Flex TC 1538		<b>cod. 03.62.09101</b>
<b>DS 0941</b>	Nera / Black	Flex TC 1538	Peso / Weight 581 g	<b>cod. 03.62.09401</b>

## DS 1201 > DA LAVABO / BASIN

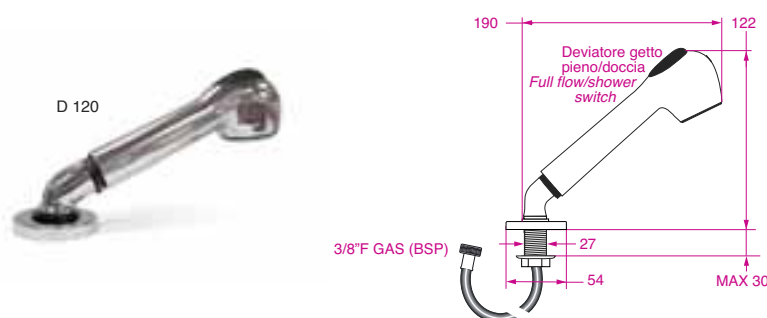

Doccia a doppio getto,  
con supporto **S10**.  
Adjustable flow, elbow shower,  
with support **S10**.

<b>DS 1201</b>		Flex TC 1538	Peso / Weight 244 g	<b>cod. 03.62.12001</b>
----------------	--	--------------	---------------------	-------------------------

Tutte le misure sono espresse in millimetri  
All measurements are in millimeters

Composizioni disponibili con flessibili di varie lunghezze  
Showers kit available in different flex lengths

## IMPUGNATURE DOCCE / SHOWERS HANDLES

### D 11 – D 14

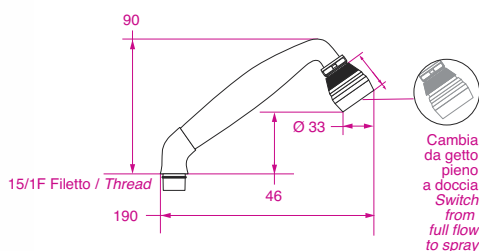

Doccia a doppio getto con gomito in ottone cromato e impugnatura in ABS.

Adjustable flow shower with chrome brass elbow and ABS shower handle.

D 11 Bianca / White

cod. 03.60.01100

D 14 Nera / Black

Peso / Weight 191 g

cod. 03.60.01400

### D 110 – D 111 – D 114

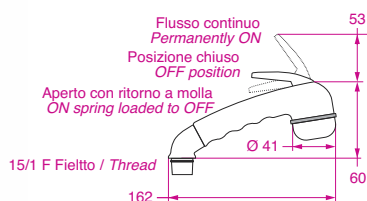

Doccia a levetta con gomito in ottone cromato e impugnatura in ABS.

Trigger shower handle with chrome brass elbow and ABS shower handle.

D 110 Cromata / Chrome

cod. 03.60.11000

D 111 Bianca / White

cod. 03.60.11100

D 114 Nera / Black

Peso / Weight 160 g

cod. 03.60.11400

### D 91 – D 94

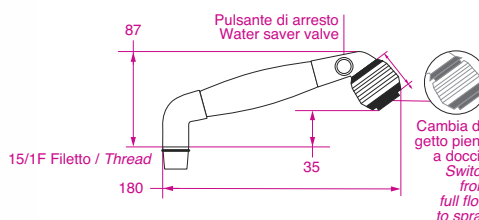

Doccia a doppio getto, con pulsante di arresto. Gomito in ottone cromato, impugnatura e soffione in ABS.

Adjustable flow, with ABS water saver valve and shower handle. Chrome brass elbow.

D 91 Bianca / White

cod. 03.60.09110

D 94 Nera / Black

Peso / Weight 317 g

cod. 03.60.09401

### D 120

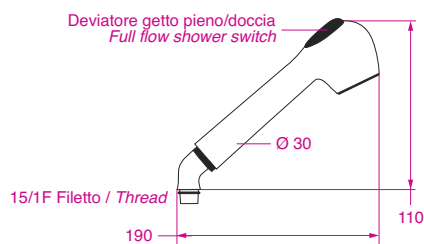

con anticalcare / with anti-scale

Doccia a doppio getto con gomito in ottone cromato e impugnatura in ABS.

Adjustable flow shower with chrome brass elbow and ABS shower handle.

D 120

Peso / Weight 209 g

cod. 03.60.12000

Tutte le misure sono espresse in millimetri  
All measurements are in millimeters

# IMPUGNATURE DOCCE / SHOWER HANDLES

## D 160

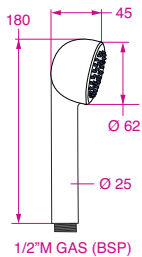

Doccia monogetto con anticalcare, costruita in ABS cromato.

Single jet shower with anti-scale, made in chrome ABS.

D 160

Peso / Weight 79 g

cod. 03.60.16000

## D 170

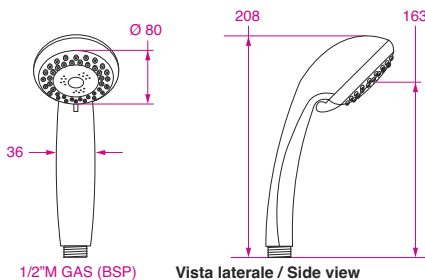

Doccia con leva di scambio getto (doccia piena, massaggio o entrambi) con anticalcare, costruita in ABS cromato.

Jet switching lever shower (full shower, massage or both) with anti-scale, made in chrome ABS.

D 170

Peso / Weight 168 g

cod. 03.60.17000

## D 180

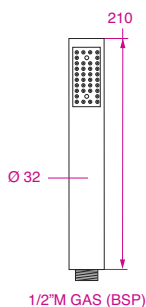

Doccia a forma cilindrica, con anticalcare, costruita in ABS cromato.

Cylindrical shower with anti-scale, made in chrome ABS.

D 180

Peso / Weight 89 g

cod. 03.60.18200

## D 180 B – D 180/K – D 180/X

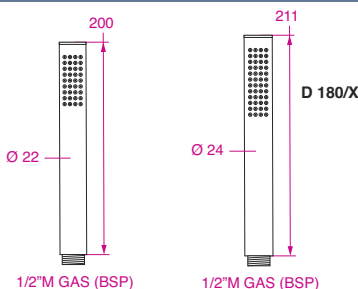

Doccia a forma cilindrica con anticalcare, costruita in ottone.

Cylindrical shower with anti-scale, made in brass.

D 180 B

Cromata / Chrome

cod. 03.60.18000

D 180/K

Nero MAT / Black MAT

cod. 03.60.18005

D 180/X

ACCIAIO INOX 316 / S/S STEEL 316

Peso / Weight 165 g

cod. 03.60.18100

## D 190 > DRITTE / STRAIGHT

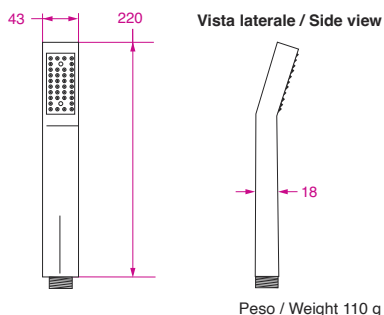

Doccia a sezione rettangolare/angolare con anticalcare, costruita in ABS cromato.

Squared section with angled handle with anti-scale, made in chrome ABS.

D 190

Peso / Weight 110 g

cod. 03.60.19000

Tutte le misure sono espresse in millimetri  
All measurements are in millimeters



D 200

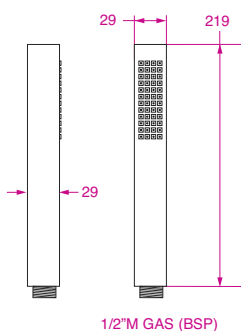

Doccia a forma quadrata con anticalcare, costruita in ABS cromato.

Square shower with anti-scale, made in chrome ABS.

D 200

Peso / Weight 120 g

cod. 03.60.20000

D 55 – D 51

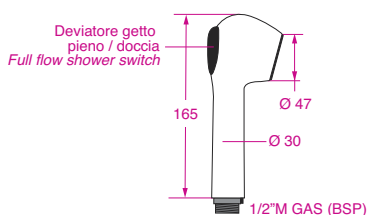

Doccia a doppio getto con anticalcare, costruita in ABS cromato.

Adjustable flow shower with anti-scale, made in chrome ABS.

D 55

Cromata / Chrome

cod. 03.60.05500

D 51

Bianca / White

Peso / Weight 132 g

cod. 03.60.05100

D 135

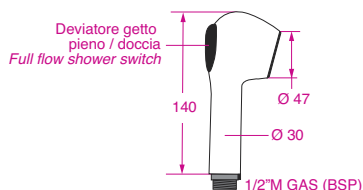

Doccia compatta a doppio getto con anticalcare, costruita in ABS cromato.

Compact double flow shower with anti-scale, made in chrome ABS.

D 135

Peso / Weight 117 g

cod. 03.60.13000

D 140

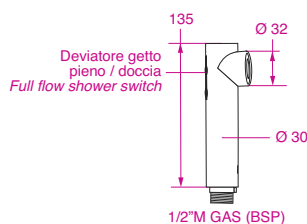

Doccia compatta a doppio getto con anticalcare, costruita in ABS cromato.

Compact double flow shower with anti-scale, made in chrome ABS.

D 140

Peso / Weight 80 g

cod. 03.60.14000

D 010 – D 011

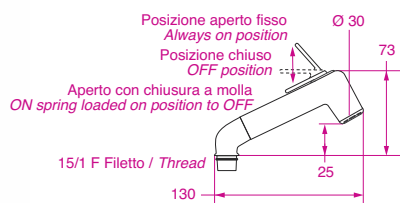

Doccia a levetta con gomito in ottone cromato e impugnatura in ABS.

Trigger shower handle with chrome brass elbow and ABS shower handle.

D 010

Cromata / Chrome

Peso / Weight 131 g

cod. 03.60.01000

D 011

Bianca / White

cod. 03.60.00110

Tutte le misure sono espresse in millimetri  
All measurements are in millimeters

# SALISCENDI / RAILS

## SS 1601

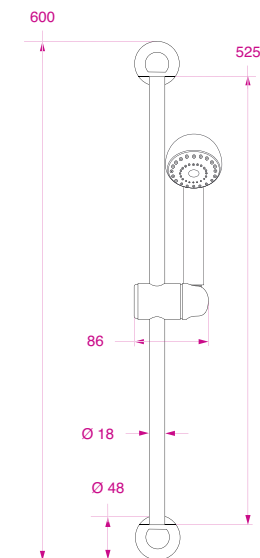

Asta e flessibile in ottone cromato. Supporti, scorrevole e doccia in ABS cromato. Corsa 480 mm. Previsto per il montaggio del portasapone **SXPSO**. Fornito con flex **TC 1538-C/2** e doccia **D160**.

A richiesta:  
TP 1538-C-00  
TP 1512-C-00  
TC 1512-C/2

Chrome brass rod and flex. Chrome ABS brackets slider and shower. Stroke 480 mm. Suitable for the soap holder **SXPSO**. Supplied with flex **TC 1538-C/2** and shower **D160**.

On request:  
TP 1538-C-00  
TP 1512-C-00  
TC 1512-C/2

**SS 1601**

Peso / Weight 637 g

**cod. 03.82.16031**

**SS 0700**

Solo saliscendi / Rail only

Peso / Weight 176 g

**cod. 03.81.00200**

## SX 1701

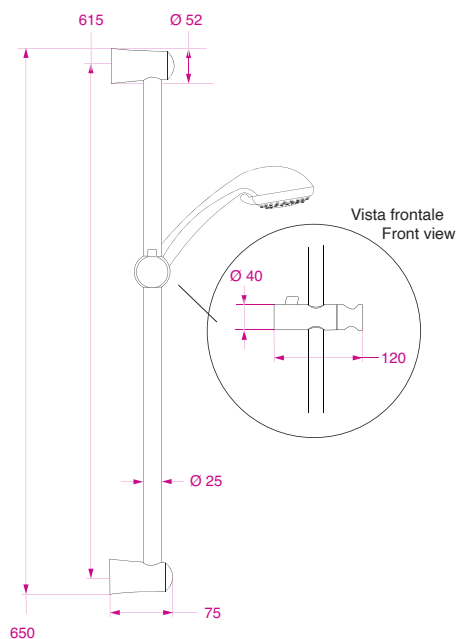

Asta e flessibile in ottone cromato. Supporti, scorrevole e doccia in ABS cromato. Corsa 480 mm. Previsto per il montaggio del portasapone **SXPSO**. Fornito con flex **TC 1538-C/2** e doccia **D170**.

A richiesta:  
TP 1538-C-00  
TP 1512-C-00  
TC 1512-C/2

Chrome brass rod and flex. Chrome ABS brackets slider and shower. Stroke 480 mm. Suitable for the soap holder **SXPSO**. Supplied with flex **TC 1538-C/2** and shower **D170**.

On request:  
TP 1538-C-00  
TP 1512-C-00  
TC 1512-C/2

**SX 1701**

Peso / Weight 781 g

**cod. 03.83.17031**

**SX 0700**

Solo saliscendi / Rail only

Peso / Weight 208 g

**cod. 03.81.00300**

Tutte le misure sono espresse in millimetri  
All measurements are in millimeters

**SY 1801**



D 180



SXPSO

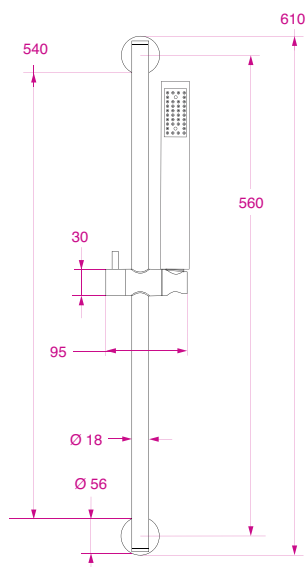

Asta e flessibile in ottone cromato.  
Supporti, scorrevole e doccia in ABS cromato.  
Corsa 510 mm.  
Previsto per il montaggio del portasapone **SXPSO**.  
Fornito con flex **TC 1538-C/2** e doccia **D 180**.

Chrome brass rod and flex.  
Chrome ABS brackets slider and shower.  
Stroke 510 mm.  
Suitable for the soap holder **SXPSO**.  
Supplied with flex **TC 1538-C/2** and shower **D 180**.

**SY 1801**

Peso / Weight 628 g

**cod. 03.84.18030**

**SY 0700**

Solo saliscendi / Rail only

Peso / Weight 172 g

**cod. 03.81.00400**

**SY 1801 B**



D 180 B

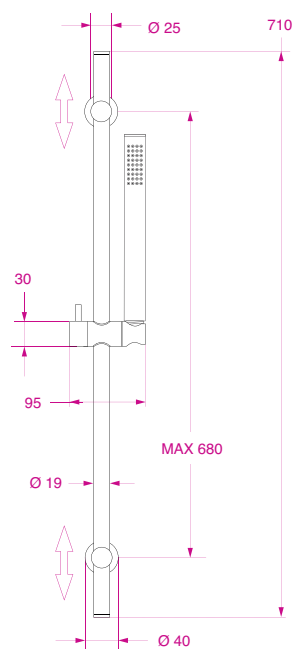

Peso / Weight 1,572 Kg

Costruito completamente in ottone cromato.  
Le staffe di supporto possono scorrere lungo l'asta per coprire eventuali fori preesistenti.  
Corsa 620 mm.  
Fornito con flex **TC 1538-C/2** e doccia **D 180 B**.

A richiesta:  
TP 1538-C-00  
TP 1512-C-00  
TC 1512-C/2

Made in chrome brass throughout.  
The brackets can slide along the rod to cover pre-existing holes, if any.  
Stroke 620 mm.  
Supplied with flex **TC 1538-C/2** and shower **D 180 B**.

On request:  
TP 1538-C-00  
TP 1512-C-00  
TC 1512-C/2

**SY 1801 B**

Peso / Weight 1,572 Kg

**cod. 03.84.18031**

**SY 0700 B**

Solo saliscendi / Rail only

Peso / Weight 1,050 Kg

**cod. 03.81.00410**

Tutte le misure sono espresse in millimetri  
All measurements are in millimeters

# SALISCENDI / RAILS

## SJ 1801 K -1/2" F

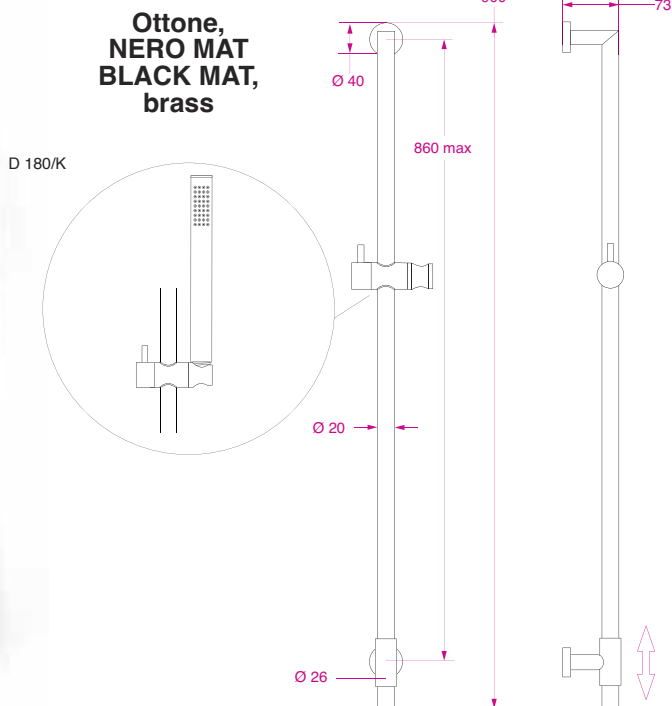

Costruito  
completamente in ottone.  
La staffa di supporto  
può scorrere lungo l'asta.  
Corsa 510 mm.  
Fornito con flex  
**TCK 1512-C/2**  
e doccia **D 180/K**.

Made in  
brass throughout.  
The bracket can slide  
along the rod.  
Stroke 510 mm.  
Supplied with flex  
**TCK 1512-C/2**  
and shower **D 180/K**.

SJ 1801 K-1/2" F

Peso / Weight 1,721 Kg

cod. 03.84.18045

## SQR 1901-00

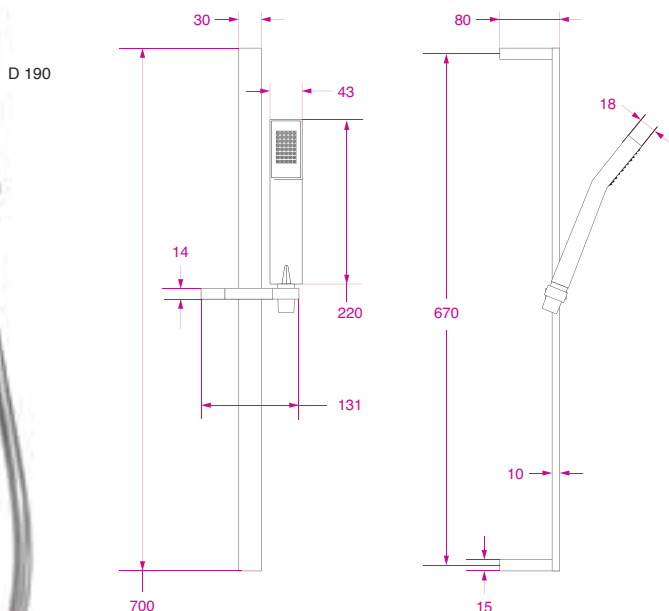

Asta rettangolare, scorrevole  
e supporti in ottone cromato.  
Flessibile e doccia  
in ABS cromato.  
Corsa 650 mm.  
Fornito con flex  
**TP 1512-C-00**  
e doccia **D 190**.

A richiesta:  
TC 1512-C/2

Chrome brass  
rectangular rod,  
slider and brackets.  
Chrome ABS  
shower and flexible.  
Stroke 650 mm.  
Supplied with flex  
**TP 1512-C-00**  
and shower **D 190**.

On request:  
TC 1512-C/2

SQR 1901-00

Peso / Weight 1,321 Kg

cod. 03.84.19072

SQR 0700

Solo saliscendi / Rail only

Peso / Weight 870 g

cod. 03.81.00502

Tutte le misure sono espresse in millimetri  
All measurements are in millimeters

**SJ 1801 X -1/2" F**



D 180/X

**ACCIAIO  
INOX 316  
S/S STEEL 316**

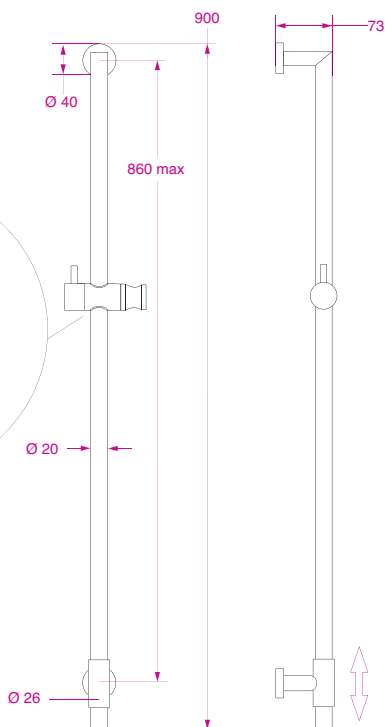
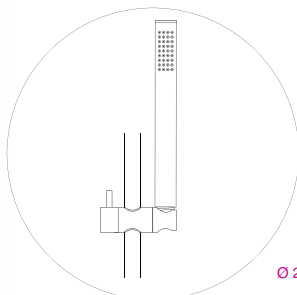

La staffa di supporto può scorrere lungo l'asta.  
Corsa 510 mm.  
Fornito con flex TP 1512-C-21 e doccia D 180/X.

The bracket can slide along the rod.  
Stroke 510 mm.  
Supplied with flex TP 1512-C-21 and shower D 180/X.

**SJ 1801 X -1/2" F**

Peso / Weight 1,798 Kg

**cod. 03.84.18055**

**SQC 2001-00**

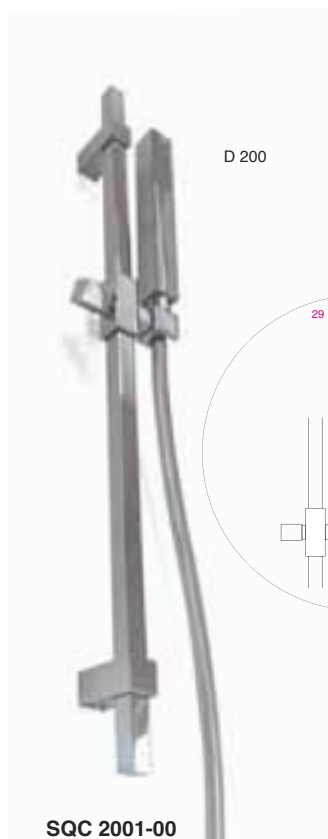

D 200

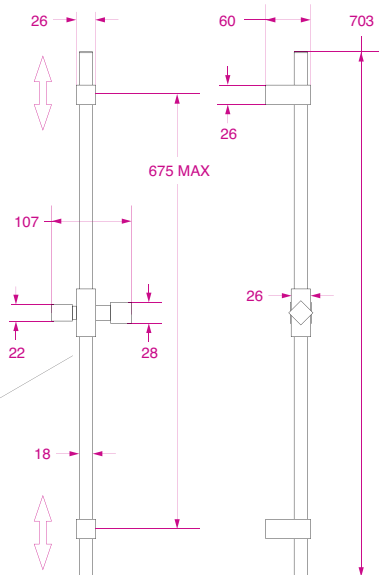
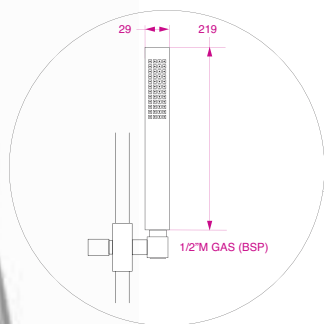

Asta quadrata, scorrevole e supporti in ottone cromato.  
Flessibile e doccia in ABS cromato.  
Le staffe di supporto possono scorrere lungo l'asta.  
Corsa 610 mm.  
Fornito con flex TP 1512-C-00 e doccia D 200.

A richiesta:  
TC 1512-C/2

Chrome brass square rod, slider and brackets.  
Chrome ABS shower and flexible.  
The brackets can slide along the rod.  
Stroke 610 mm.  
Supplied with flex TP 1512-C-00 and shower D 200.

On request:  
TC 1512-C/2

**SQC 2001-00  
SQC 0700**

Solo saliscendi / Rail only

Peso / Weight 1,425 Kg

Peso / Weight 970 g

**cod. 03.84.20070**

**cod. 03.81.00504**





## TUBI / HOSES

### 1/2" F – 1/2" C > PER DOCCE DRITTE / FOR STRAIGHT SHOWERS

Tubo in ottone cromato, RINFORZATO  
HEAVY DUTY chrome brass hose

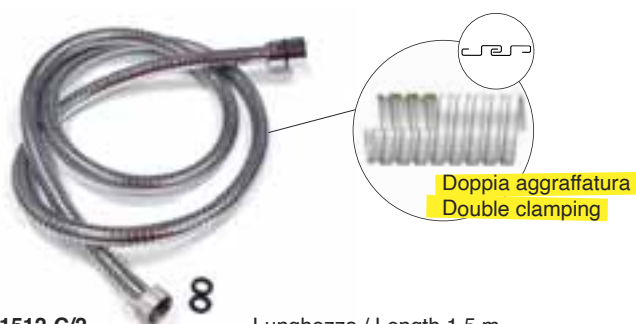

TC 1512-C/2	Lunghezza / Length 1,5 m	Peso / Weight 320 g	cod. 03.70.21231
TC 2012-C/2	Lunghezza / Length 2 m	Peso / Weight 380 g	cod. 03.70.21232

### 1/2" F – 1/2" C > PER DOCCE DRITTE / FOR STRAIGHT SHOWERS

Tubo in plastica con spirale cromata / Plastic hose with chrome spiral



TP 1512-C/00	Lunghezza / Length 1,5 m	Peso / Weight 260 g	cod. 03.71.21271
TP 2012-C/00	Lunghezza / Length 2 m	Peso / Weight 300 g	cod. 03.71.21272

### 1/2" F – 1/2" C > PER DOCCE DRITTE / FOR STRAIGHT SHOWERS

Tubo bianco in plastica retinata / Reinforced white plastic hose

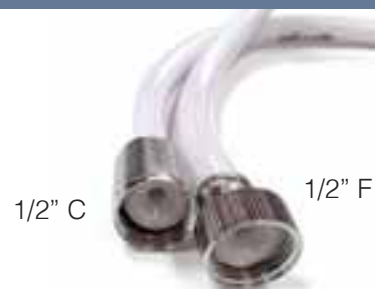

TP 1512-C/1	Lunghezza / Length 1,5 m	Peso / Weight 250 g	cod. 03.71.21211
TP 2012-C/1	Lunghezza / Length 2 m	Peso / Weight 290 g	cod. 03.71.21212
TP 3012-C/1	Lunghezza / Length 3 m	Peso / Weight 340 g	cod. 03.71.21214

**1/2" F – 1/2" C > PER DOCCE DRITTE / FOR STRAIGHT SHOWERS**

Tubo in plastica grigio metallizzato / Plastic grey silver hose



**TP 1512-C-11**

Lunghezza / Length 1,5 m

Peso / Weight 260 g

**cod. 03.71.21261**

**1/2" F – 1/2" C > PER DOCCE DRITTE / FOR STRAIGHT SHOWERS**

Tubo in ottone nero MAT, RINFORZATO  
BLACK MAT brass, HEAVY DUTY

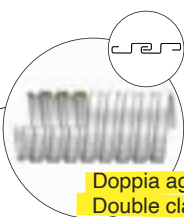

Doppia aggraffatura  
Double clamping



**TCK 1512-C/2**

Lunghezza / Length 1,5 m

Peso / Weight 216 g

**cod. 03.70.21233**

**1/2" F – 1/2" C > PER DOCCE DRITTE / FOR STRAIGHT SHOWERS**

Tubo in silicone, nero / Black silicon



**TPS 1512-C/4**

Lunghezza / Length 1,5 m

Peso / Weight 265 g

**cod. 03.71.21281**

**1/2" F – 1/2" C > PER DOCCE DRITTE / FOR STRAIGHT SHOWERS**

Tubo in plastica nichelata spazzolata / Nikel-plated and brushed plastic hose



**TP 1512-C-21**

Lunghezza / Length 1,5 m

Peso / Weight 293 g

**cod. 03.71.21251**

**3/8" F – 1/2" C > PER DOCCE DRITTE / FOR STRAIGHT SHOWERS**

Tube in ottone cromato, RINFORZATO / HEAVY DUTY chrome brass hose

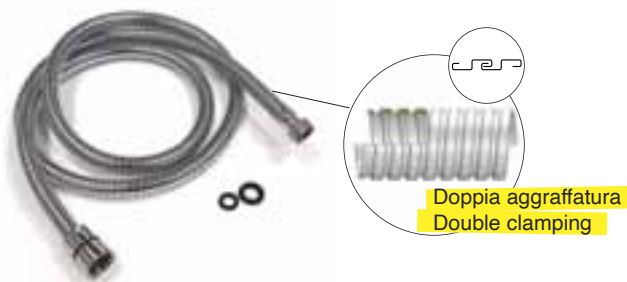

<b>TC 1538-C/2</b>	Lunghezza / Length 1,5 m	Peso / Weight 300 g	<b>cod. 03.70.23831</b>
<b>TC 2038-C/2</b>	Lunghezza / Length 2 m	Peso / Weight 370 g	<b>cod. 03.70.23832</b>

**3/8" F – 1/2" C > PER DOCCE DRITTE / FOR STRAIGHT SHOWERS**

Tube in plastica con spirale cromata / Plastic hose with chrome spiral



<b>TP 1538-C/00</b>	Lunghezza / Length 1,5 m	Peso / Weight 220 g	<b>cod. 03.71.23871</b>
<b>TP 2038-C/00</b>	Lunghezza / Length 2 m	Peso / Weight 270 g	<b>cod. 03.71.23872</b>
<b>TP 3038-C/00</b>	Lunghezza / Length 3 m	Peso / Weight 370 g	<b>cod. 03.71.23874</b>
<b>TP 4038-C/00</b>	Lunghezza / Length 4 m	Peso / Weight 490 g	<b>cod. 03.71.23875</b>

**3/8" F – 1/2" C > PER DOCCE DRITTE / FOR STRAIGHT SHOWERS**

Tube bianco in plastica retinata / Reinforced white plastic hose



<b>TP 1538-C/1</b>	Lunghezza / Length 1,5 m	Peso / Weight 210 g	<b>cod. 03.71.23811</b>
<b>TP 2038-C/1</b>	Lunghezza / Length 2 m	Peso / Weight 250 g	<b>cod. 03.71.23812</b>
<b>TP 2538-C/1</b>	Lunghezza / Length 2,5 m	Peso / Weight 300 g	<b>cod. 03.71.23813</b>
<b>TP 3038-C/1</b>	Lunghezza / Length 3 m	Peso / Weight 350 g	<b>cod. 03.71.23814</b>
<b>TP 4038-C/1</b>	Lunghezza / Length 4 m	Peso / Weight 470 g	<b>cod. 03.71.23815</b>
<b>TP 6038-C/1</b>	Lunghezza / Length 6 m	Peso / Weight 693 g	<b>cod. 03.71.23817</b>

**3/8" F – 1/2" C > PER DOCCE DRITTE / FOR STRAIGHT SHOWERS**

Tube nero in plastica retinata / Reinforced black plastic hose

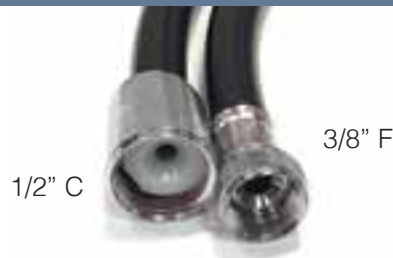

<b>TP 2038-C/4</b>	Lunghezza / Length 2 m	Peso / Weight 250 g	<b>cod. 03.71.23842</b>
<b>TP 3038-C/4</b>	Lunghezza / Length 3 m	Peso / Weight 350 g	<b>cod. 03.71.23844</b>
<b>TP 4038-C/4</b>	Lunghezza / Length 4 m	Peso / Weight 470 g	<b>cod. 03.71.23845</b>

**3/8" F - 15/1 M > PER DOCCE CON CURVA / FOR ELBOW SHOWERS**

Tubo in ottone cromato / Chrome brass hose

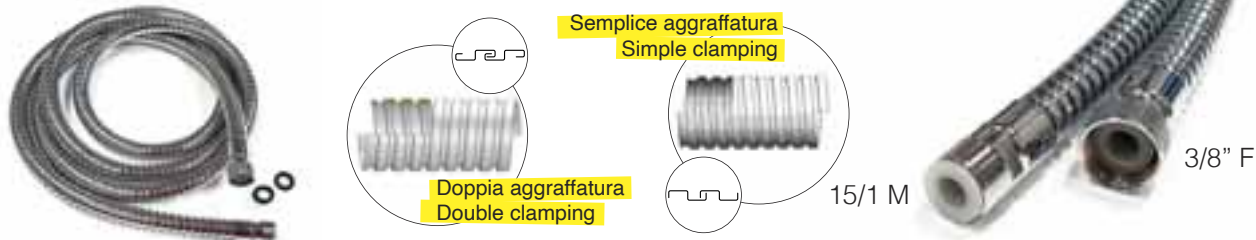

**Doppia aggraffatura / Double clamping RINFORZATO / HEAVY DUTY**

TC 1538/2	Lunghezza / Length 1,5 m	Peso / Weight 270 g	cod. 03.70.13831
TC 2038/2	Lunghezza / Length 2 m	Peso / Weight 380 g	cod. 03.70.13832

**Semplice aggraffatura / Simple clamping**

TC 1538	Lunghezza / Length 1,5 m	Peso / Weight 200 g	cod. 03.70.13801
TC 2038	Lunghezza / Length 2 m	Peso / Weight 260 g	cod. 03.70.13802

**3/8" F - 15/1 M > PER DOCCE CON CURVA / FOR ELBOW SHOWERS**

Tubo in plastica con spirale cromata / Plastic hose with chrome spiral

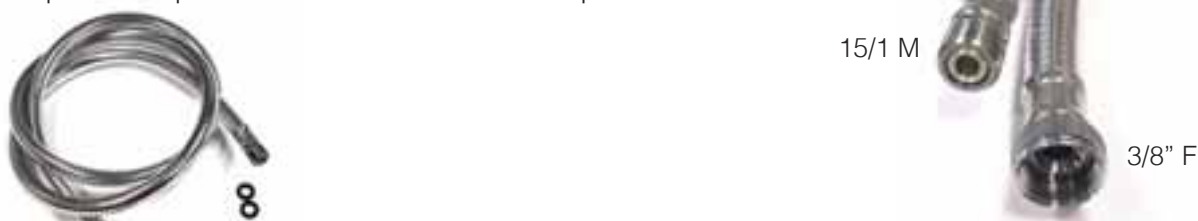

TP 1538-00	Lunghezza / Length 1,5 m	Peso / Weight 200 g	cod. 03.71.13871
TP 2038-00	Lunghezza / Length 2 m	Peso / Weight 290 g	cod. 03.71.13872
TP 3038-00	Lunghezza / Length 3 m	Peso / Weight 350 g	cod. 03.71.13874
TP 4038-00	Lunghezza / Length 4 m	Peso / Weight 450 g	cod. 03.71.13875

**3/8" F - 15/1 M > PER DOCCE CON CURVA / FOR ELBOW SHOWERS**

Tubo bianco in plastica retinata / Reinforced white plastic hose



TP 1538/1	Lunghezza / Length 1,5 m	Peso / Weight 200 g	cod. 03.71.13811
TP 2038/1	Lunghezza / Length 2 m	Peso / Weight 250 g	cod. 03.71.13812
TP 3038/1	Lunghezza / Length 3 m	Peso / Weight 340 g	cod. 03.71.13814
TP 4038/1	Lunghezza / Length 4 m	Peso / Weight 450 g	cod. 03.71.13815

**3/8" F - 15/1 M > PER DOCCE CON CURVA / FOR ELBOW SHOWERS**

Tubo nero in plastica retinata / Reinforced black plastic hose



TP 1538/4	Lunghezza / Length 1,5 m	Peso / Weight 200 g	cod. 03.71.13841
TP 2038/4	Lunghezza / Length 2 m	Peso / Weight 250 g	cod. 03.71.13842
TP 3038/4	Lunghezza / Length 3 m	Peso / Weight 340 g	cod. 03.71.13844
TP 4038/4	Lunghezza / Length 4 m	Peso / Weight 450 g	cod. 03.71.13845



**15/1 M - 1/2" C > PER MISCELATORI DOCCIA ESTRAIBILE/ FOR PULL-OUT SHOWER MIXERS**

Tubo in ottone cromato, RINFORZATO / HEAVY DUTY chrome brass hose

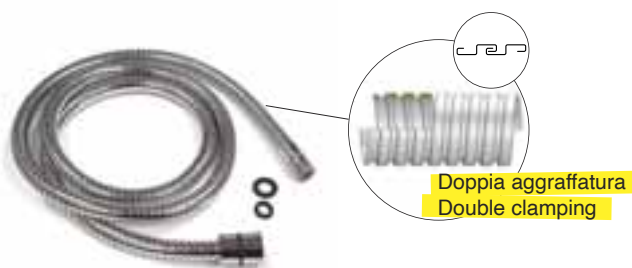

<b>TC 1538-M</b>	Lunghezza / Length 1,5 m	Peso / Weight 300 g	<b>cod. 03.70.23881</b>
<b>TC 2038-M</b>	Lunghezza / Length 2 m	Peso / Weight 400 g	<b>cod. 03.70.23882</b>

**15/1 M - 1/2" C > PER MISCELATORI DOCCIA ESTRAIBILE/ FOR PULL-OUT SHOWER MIXERS**

Tubo grigio in plastica retinata / Reinforced plastic grey hose



Con calza a rete e contrappeso in polipropilene Ø 14

With grey sock and polypropilene dia 14 counterbalance



<b>TP 1538-M</b>	Lunghezza / Length 1,5 m	Peso / Weight 290 g	<b>cod. 03.71.23821</b>
<b>TP 2038-M</b>	Lunghezza / Length 2 m	Peso / Weight 370 g	<b>cod. 03.71.23822</b>



**15/1 M - 15/1 M > PER MISCELATORI DOCCIA ESTRAIBILE/ FOR PULL-OUT SHOWER MIXERS**

Tubo grigio in plastica retinata / Reinforced plastic grey hose



Con calza a rete e contrappeso in piombo

With grey sock and lead counterbalance

**SPECIFICO PER  
SPECIFIC FOR  
MY 1822-1/2" F**



<b>TP 2015-MM</b>	Lunghezza / Length 2 m	Peso / Weight 290 g	<b>cod. 03.71.11522</b>
-------------------	------------------------	---------------------	-------------------------



## FLESSIBILI SOTTORUBINETTO / WATER SUPPLY FLEXIBLES FOR MIXERS

### FLX 813821

Terminali in ottone cromato, tubo interno in plastica alimentare, guaina in acciaio inox – 21 cm  
 Made with chrome brass terminals and plastic non toxic hose with s/s sock – 21 cm



3/8" M GAS (BSP)

8/1

<b>FLX 813821B</b>	BLUE	8X1M - 3/8" M	Peso/Weight 44 g	<b>cod. 03.59.00401</b>
<b>FLX 813821R</b>	RED	8X1M - 3/8" M		<b>cod. 03.59.00402</b>

### FLX 811221

Terminali in ottone cromato, tubo interno in plastica alimentare, guaina in acciaio inox – 21 cm  
 Made with chrome brass terminals and plastic non toxic hose with s/s sock – 21 cm



1/2" F GAS (BSP)

8/1

<b>FLX 811221B</b>	BLUE	8X1M - 1/2" F	Peso/Weight 50 g	<b>cod. 03.59.00403</b>
<b>FLX 811221R</b>	RED	8X1M - 1/2" F		<b>cod. 03.59.00404</b>

### FLX 103821

Terminali in ottone cromato, tubo interno in plastica alimentare, guaina in acciaio inox – 21 cm  
 Made with chrome brass terminals and plastic non toxic hose with s/s sock – 21 cm



3/8" M GAS (BSP)

10/1

<b>FLX 103821B</b>	BLUE	10X1M - 3/8" M	Peso/Weight 46 g	<b>cod. 03.59.00405</b>
<b>FLX 103821R</b>	RED	10X1M - 3/8" M		<b>cod. 03.59.00406</b>

### FLX 101221

Terminali in ottone cromato, tubo interno in plastica alimentare, guaina in acciaio inox – 21 cm  
 Made with chrome brass terminals and plastic non toxic hose with s/s sock – 21 cm



1/2" F GAS (BSP)

10/1

<b>FLX 101221B</b>	BLUE	10X1M - 1/2" F	Peso/Weight 52 g	<b>cod. 03.59.00407</b>
<b>FLX 101221R</b>	RED	10X1M - 1/2" F		<b>cod. 03.59.00408</b>

## ACCESSORI / ACCESSORIES

### SFK 0700 > SUPPORTO PER DOCCIA DRITTA / BULKHEAD HOLDER FOR STRAIGHT SHOWER

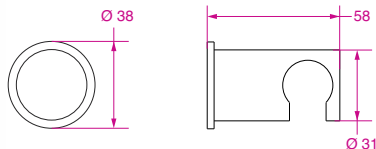

Supporto fisso, per docce dritte.  
Costruito in ottone, **NERO MAT.**

Fixed straight showers holder.  
Made in brass, **BLACK MAT.**

SFK 0700

cod. 03.80.00023

### SF 0700 > SUPPORTO PER DOCCIA DRITTA / BULKHEAD HOLDER FOR STRAIGHT SHOWER

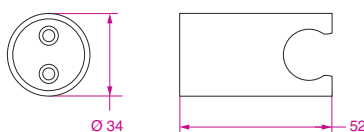

Supporto fisso, per docce dritte.  
Costruito in ABS cromato.

Fixed straight showers holder.  
Made in chrome ABS.

SF 0700

Peso / Weight 22 g

cod. 03.80.00022

### SP 0700 > SUPPORTO PER DOCCIA DRITTA / BULKHEAD HOLDER FOR STRAIGHT SHOWER

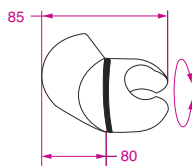

Supporto rotante, per docce dritte.  
Costruito in ABS cromato.

Articulated straight shower holder.  
Made in chrome ABS.

SP 0700

Peso / Weight 54 g

cod. 03.80.00021

### SD 0100 > SUPPORTO PER DOCCIA CON GOMITO / BULKHEAD HOLDER FOR ELBOW SHOWER

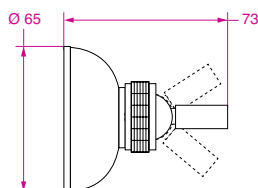

Supporto a forcella snodata,  
per docce con curva conica.  
Costruito in zama cromata.

Shower support with adjustable fork,  
for elbow showers.  
Made in chrome zamak.

SD 0100

Peso / Weight 89 g

cod. 03.80.00010

### SD 0700 > SUPPORTO PER DOCCIA DRITTA / BULKHEAD HOLDER FOR STRAIGHT SHOWER

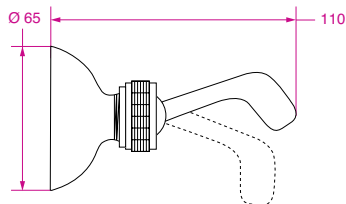

Supporto snodato, per docce dritte.  
Solido, metallico, ad attrito  
regolabile mediante ghiera.  
Corpo e forcella in ottone cromato.

Articulated straight shower holder.  
The adjustable stem  
allows to choose  
right position of the shower.  
Body and stem  
Made in chrome brass.

SD 0700

Peso / Weight 196 g

cod. 03.80.00020

Tutte le misure sono espresse in millimetri  
All measurements are in millimeters

**SX PSO > PORTASAPONE / SOAP HOLDER**



Porta sapone per saliscendi.  
Adatto ad aste Ø 25 mm  
(**SX 1701 - SX 0700**)  
e con riduzione per aste Ø 18 mm  
(**SS 1601 - SS 0700** e  
**SY 1801 - SY 0700**).  
Costruito in ABS cromata.

Soap holder for rails.  
Suitable for tubes dia 25 mm  
(**SX 1701 - SX 0700**) and supplied  
with an adaptor for tubes dia 18 mm  
(**SS 1601 - SS 0700** and  
**SY 1801 - SY 0700**).  
Made in chrome ABS.

**SX PSO**

Peso / Weight 68 g

**cod. 03.85.00020**

**S10 - S30 > SUPPORTO SOPRA PIANO PER DOCCE / GROMMET FOR SHOWERS**

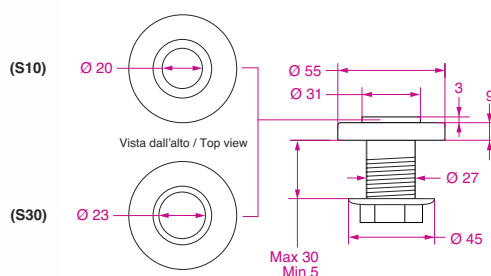

Supporto sopra piano per **kit docce**.  
Boccola e dado in plastica.  
Rosone in acciaio inox lucido.

Grommet for **showers kit**.  
Stem and nut in plastic.  
Top plate in polished stainless steel.

**S 10**

Per docce con curva / For elbow showers

Peso / Weight 35 g

**cod. 03.85.21000**

**S 30**

Per docce dritte / For straight showers

Peso / Weight 32 g

**cod. 03.85.23000**

**BGQ 0012 > RACCORDO PASSAPARATIA / ELBOW BULKHEAD WATER CONNECTION**

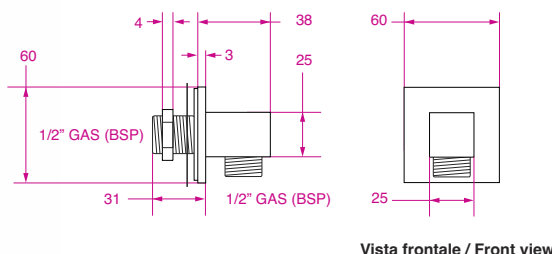

Raccordo passa-paratia, squadrato.  
Costruito in ottone cromato.  
Particolarmente appropriato  
in combinazione con il saliscendi  
**SQ 1901-00**.

Squared through bulkhead  
elbow connection.  
Made in chrome brass.  
Particularly suitable  
in combination with the slider  
**SQ 1901-00**.

**BGQ 0012**

Peso / Weight 240 g

**cod. 03.85.02012**

**BG 00 > RACCORDO PASSAPARATIA / ELBOW BULKHEAD WATER CONNECTION**

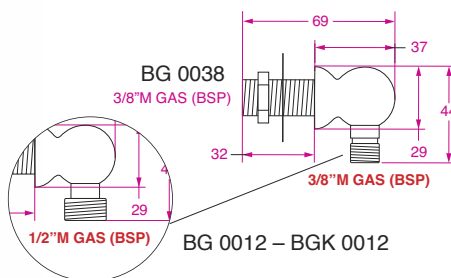

Raccordo passa paratia a gomito.  
Molto compatto, di ingombri ridotti  
e forme arrotondate.  
Costruito in ottone cromato.

Through bulkhead  
elbow connection.  
Compact size and smoothed shape,  
suitable in combination  
of most designs.  
Made in chrome brass.

**BG 0038**

Raccordi uscita / Outlet thread 3/8" M x 3/8" M

Peso / Weight 170 g

**cod. 03.85.01038**

**BG 0012**

Raccordi uscita / Outlet thread 3/8" M x 1/2" M

Peso / Weight 177 g

**cod. 03.85.01012**

**BGK 0012**

Ottone, **NERO MAT** / Made in brass, **BLACK MAT**

**cod. 03.85.01013**

Tutte le misure sono espresse in millimetri  
All measurements are in millimeters

## ACCESSORI BAGNO / BATHROOM ACCESSORIES

### AB\_GAN > GANCIO / HOOK

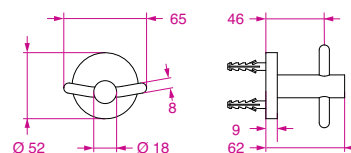

**AB\_GAN** Cromato / Chrome

**cod. 03.90.00006**

**ABK\_GAN** Nero mat / Black mat

Peso / Weight 0,297 Kg

**cod. 03.90.00001**

### AB\_PS > PORTASALVIETTE / TOWEL RACK

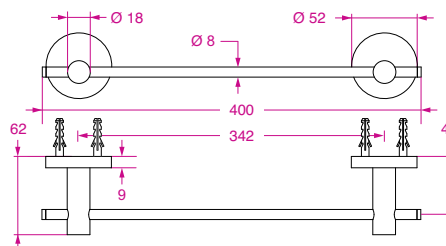

**AB\_PS** Cromato / Chrome

**cod. 03.90.00007**

**ABK\_PS** Nero mat / Black mat

Peso / Weight 0,532 Kg

**cod. 03.90.00002**

### AB\_SPZ > PORTA SPAZZOLINI / TOOTHBRUSH HOLDER

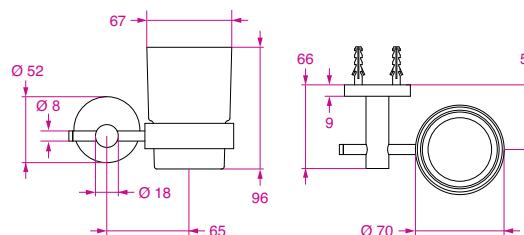

**AB\_SPZ** Cromato / Chrome

**cod. 03.90.00008**

**ABK\_SPZ** Nero mat / Black mat

Peso / Weight 0,557 Kg

**cod. 03.90.00003**

### ABK\_SAP > PORTASAPONE / SOAP HOLDER

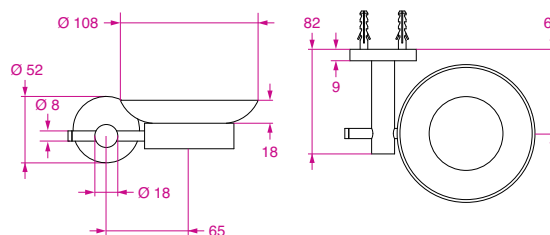

**AB\_SAP** Cromato / Chrome

**cod. 03.90.00009**

**ABK\_SAP** Nero mat / Black mat

Peso / Weight 0,586 Kg

**cod. 03.90.00004**

### ABK\_ROT > PORTA ROTOLO / TOILET PAPER HOLDER

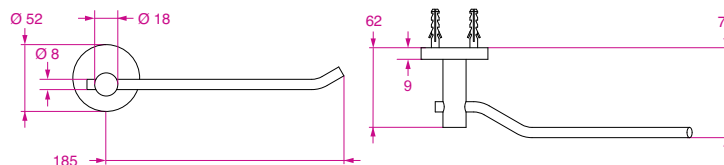

**AB\_ROT** Cromato / Chrome

**cod. 03.90.00010**

**ABK\_ROT** Nero mat / Black mat

Peso / Weight 0,200 Kg

**cod. 03.90.00005**

Tutte le misure sono espresse in millimetri  
All measurements are in millimeters





## SPEEDFIT

Articolo Item	Ø tubo hose dia	Ø codolo stem dia	filetto thread	peso weight	codice code
------------------	--------------------	----------------------	-------------------	----------------	----------------

### RACCORDO DRITTO / STRAIGHT CONNECTOR



PM 0412 E	12			13 g	cod. 04.01.00000
PEM 0415 W	15			30 g	cod. 04.02.00000
PEM 0422 W	22			53 g	cod. 04.03.00000

### RACCORDO A GOMITO / ELBOW CONNECTOR



PM 0312 E	12			15 g	cod. 04.01.00005
PEM 0315 W	15			35 g	cod. 04.02.00005
PEM 0322 W	22			64 g	cod. 04.03.00005

### RACCORDO A "T" / "T" CONNECTOR



PM 0212 E	12			22 g	cod. 04.01.00010
PEM 0215 W	15			50 g	cod. 04.02.00010
PEM 0222 W	22			90 g	cod. 04.03.00010

### RACCORDO A "Y" / "Y" CONNECTOR



CM 2312 W	12			22 g	cod. 04.01.00015
-----------	----	--	--	------	------------------

### TERMINALE MASCHIO / MALE ADAPTOR



PM 011213 E	12		3/8" M	10 g	cod. 04.01.00020
PM 011214 E	12		1/2" M	13 g	cod. 04.01.00021
PM 011513 E	15		3/8" M	15 g	cod. 04.02.00020
CM 011514 S	15		1/2" M	15 g	cod. 04.02.00021
PM 011516 E	15		3/4" M	24 g	cod. 04.02.00022
CM 012216 S	22		3/4" M	39 g	cod. 04.03.00022

### TERMINALE FEMMINA / FEMALE ADAPTOR



ADATTI AD IMPIANTI DI RISCALDAMENTO  
SUITABLE FOR CENTRAL HEATING SYSTEMS

CM 451213 FS	12		3/8" F	11 g	cod. 04.01.00030
CM 451214 FS	12		1/2" F	12 g	cod. 04.01.00031
CM 451513 FS	15		3/8" F	14 g	cod. 04.02.00030
CM 3201 S	15		1/2" F	19 g	cod. 04.02.00031
PSE 3201 W	15		1/2" F	14 g	cod. 04.02.00033
PSE 3203 W	15		3/4" F	19 g	cod. 04.02.00032
PSE 3202 W	22		3/4" F	15 g	cod. 04.03.00032

### PASSA PARATIA / BULKHEAD CONNECTOR



PM 1212 E	12			48 g	cod. 04.01.00040
-----------	----	--	--	------	------------------

### RUBINETTO A SFERA / SHUT-OFF VALVE



15 ESOT	15			44 g	cod. 04.02.00045
---------	----	--	--	------	------------------

### RUBINETTO DI EMERGENZA / SERVICE VALVE



15 SV	15			34 g	cod. 04.02.00050
-------	----	--	--	------	------------------

Tutte le misure sono espresse in millimetri – Tutti i filetti in BSP (GAS)  
All measurements are in millimeters – All threads are BSP

E Nero/Black  
W Bianco/White  
S Grigio/Grey

Articolo Item	Ø tubo hose dia	Ø codolo stem dia	filetto thread	peso weight	codice code
<b>CODOLO MASCHIO / MALE STEM ADAPTOR</b>					
PM 051213 E		12	3/8" M	8 g	cod. 04.01.00055
PM 051214 E		12	1/2" M	11 g	cod. 04.01.00056
PM 051513 E		15	3/8" M	9 g	cod. 04.02.00055
PM 051514 E		15	1/2" M	14 g	cod. 04.02.00056
PM 052214 E		22	1/2" M	18 g	cod. 04.03.00056
PM 052216 E		22	3/4" M	29 g	cod. 04.03.00057



<b>CODOLO FEMMINA IN OTTONE / FEMALE BRASS STEM ADAPTOR</b>					
MM 501514 N		15	1/2" F	55 g	cod. 04.02.00065



<b>GOMITO CON CODOLO / STEM ELBOW</b>					
PM 221212 E	12	12		11 g	cod. 04.01.00070
PEM 221515 W	15	15		21 g	cod. 04.02.00070
PEM 222222 W	22	22		39 g	cod. 04.03.00070



<b>GOMITO CON RACCORDO IN OTTONE / THREADED STEM ELBOW (BRASS NUT)</b>					
PEM BTC 1514	15		1/2" F	45 g	cod. 04.02.00076



<b>RIDUZIONE INTERMEDIA / STRAIGHT REDUCER</b>					
PM 201210 E	12 x 10			17 g	cod. 04.01.00081
CM 201510 S	15 x 10			14 g	cod. 04.02.00081



<b>RIDUZIONE A GOMITO / REDUCER ELBOW</b>					
PM 211208 E	12 x 8			18 g	cod. 04.01.00086
PM 211210 E	12 x 10			21 g	cod. 04.01.00085



<b>RIDUZIONE / REDUCER</b>					
PPM 061512 W	12	15		9 g	cod. 04.01.00090
PEM 062215 W	15	22		23 g	cod. 04.02.00090



<b>RACCORDO PORTAGOMMA / BARB CONNECTOR</b>					
NC 757	12	13 – 1/2"		40 g	cod. 04.01.00095
NC 473	22	19 – 3/4"		26 g	cod. 04.03.00095



<b>TERMINALE CIECO / END STOP</b>					
PM 4612 E	12			7 g	cod. 04.01.00100
PM 4615 E	15			10 g	cod. 04.02.00100
PSE 4622 W	22			21 g	cod. 04.03.00100



Tutte le misure sono espresse in millimetri – Tutti i filetti in BSP (GAS)  
All measurements are in millimeters – All threads are BSP

## SPEEDFIT

Articolo Item	Ø tubo hose dia	Ø codolo stem dia	filetto thread	peso weight	codice code
------------------	--------------------	----------------------	-------------------	----------------	----------------

### TAPPO / PLUG



PM 0812 R		12		5 g	cod. 04.01.00105
PL 15		15		6 g	cod. 04.02.00105
PL 22		22			cod. 04.03.00105

### CLIPS BLOCCA COLLETTA ( ROSSE, BLU O BIANCHE) / LOCKING CLIP (RED, BLUE OR WHITE)



PKM 1812-R	12			1 g	cod. 04.01.00110
PKM 1815-B	15			1 g	cod. 04.02.00111
PKM 1822-W	22			1 g	cod. 04.03.00110

### COPRICOLLETTA (ROSSO O BLU) / COLLET COVER (RED OR BLUE)



PM 1912-R	12			2 g	cod. 04.01.00115
PM 1912-B	12			2 g	cod. 04.01.00116

### ATTACCO SERBATOIO / TANK CONNECTOR



CM 0722 S	22			57 g	cod. 04.03.00120
-----------	----	--	--	------	------------------

### ATTACCO BOILER / CONNECTOR FOR WATER HEATERS



FLX 1212

Peso / Weight 124 g

cod. 04.01.00200

### TUBI PER ACQUA USO ALIMENTARE IN POLIETILENE / FOOD GRADE PIPES



Articolo / Item		Ø		codice / code
PTL 1209 B	blue	12 x 9	hot / cold - spool 100 m	cod. 04.10.12093
PTL 1209 R	red	12 x 9	hot / cold - spool 100 m	cod. 04.10.12092
PTL 1511 B	blue	15 x 11,5	hot / cold - coil 100 m	cod. 04.10.15111
PTL 1511 R	red	15 x 11,5	hot / cold - coil 100 m	cod. 04.10.15112
PTL 2218	white	22 x 18	hot / cold - coil 50 m	cod. 04.10.22183

### CLIPS PER TUBI / MOUNTING CLIPS



Articolo / Item	Ø	barre / stick	peso / weight	codice / code
CLP 12	12	10 pezzi / pieces	36 g	cod. 04.09.00012
CLP 15	15	8 pezzi / pieces	37 g	cod. 04.09.00015

### CESOIA / CUTTER

per tubi fino a Ø 12/14 / for hoses up to 12/14 mm dia



STCUT 12

Peso / Weight 107 g

cod. 04.09.10000

### CESOIA / CUTTER

per tubi fino a Ø 26/28 / for hoses up to 26/28 mm dia



ST CUT 26

Peso / Weight 290 g

cod. 04.09.10002

Tutte le misure sono espresse in millimetri / All measurements are in millimeters



## RACCORDERIA / FITTINGS

E Nero/Black W Bianco/White S Grigio/Grey

### PORTAGOMMA F HOSETAIL

In polipropilene con calotta girevole e guarnizione  
Made in polypropilene with swivel cap and gasket



<b>PG 3812</b>	<b>S</b>	3/8" F x 12 mm	5 g	<b>cod. 04.20.13812</b>
<b>PG 1213</b>	<b>E</b>	1/2" F x 13 mm	7 g	<b>cod. 04.20.11213</b>
<b>PG 1216</b>	<b>E</b>	1/2" F x 16 mm	9 g	<b>cod. 04.20.11216</b>
<b>PG 3416</b>	<b>E</b>	3/4" F x 16 mm	12 g	<b>cod. 04.20.13416</b>
<b>PG 1420</b>	<b>E</b>	1"1/4 F x 20 mm	24 g	<b>cod. 04.20.11420</b>
<b>PG 1425</b>	<b>E</b>	1"1/4 F x 25 mm	26 g	<b>cod. 04.20.11425</b>

### PORTAGOMMA M HOSETAILS

In polipropilene / Made in polypropilene



<b>PM 3812</b>	<b>S</b>	3/8" M x 12 mm	5 g	<b>cod. 04.20.33812</b>
<b>PM 3813</b>	<b>S</b>	3/8" M x 13 mm	5 g	<b>cod. 04.20.33813</b>
<b>PM 3816</b>	<b>S</b>	3/8" M x 16 mm	7 g	<b>cod. 04.20.33816</b>
<b>PM 1213</b>	<b>E</b>	1/2" M x 13 mm	7 g	<b>cod. 04.20.31213</b>
<b>PM 1216</b>	<b>E</b>	1/2" M x 16 mm	7 g	<b>cod. 04.20.31216</b>
<b>PM 1220</b>	<b>E</b>	1/2" M x 20 mm	11 g	<b>cod. 04.20.31220</b>
<b>PM 3413</b>	<b>E</b>	3/4" M x 13 mm	13 g	<b>cod. 04.20.33413</b>
<b>PM 3416 WE</b>		3/4" M x 16 mm	11 g	<b>cod. 04.20.33416</b>
<b>PM 3420</b>	<b>E</b>	3/4" M x 20 mm	14 g	<b>cod. 04.20.33420</b>

### PORTAGOMMA A GOMITO F ELBOW HOSETAIL

In polipropilene  
Made in polypropilene



<b>PGE 1212</b>	<b>E</b>	1/2" F x 12 mm	8 g	<b>cod. 04.20.21212</b>
<b>PGE 3416</b>	<b>E</b>	3/4" F x 16 mm	12 g	<b>cod. 04.20.23416</b>
<b>PGE 1425</b>	<b>E</b>	1"1/4 F x 25 mm	29 g	<b>cod. 04.20.21425</b>

### PORTAGOMMA A GOMITO M ELBOW HOSETAIL

In polipropilene  
Made in polypropilene



<b>PEM 3812</b>	<b>S</b>	3/8" M x 12 mm	5 g	<b>cod. 04.20.43812</b>
<b>PEM 1213</b>	<b>E</b>	1/2" M x 13 mm	6 g	<b>cod. 04.20.41213</b>
<b>PEM 1216</b>	<b>E</b>	1/2" M x 16 mm	8 g	<b>cod. 04.20.41216</b>
<b>PEM 1220</b>	<b>E</b>	1/2" M x 20 mm	12 g	<b>cod. 04.20.41220</b>
<b>PEM 3412</b>	<b>E</b>	3/4" M x 12 mm	8 g	<b>cod. 04.20.43412</b>

Tutte le misure sono espresse in millimetri – Tutti i filetti in BSP (GAS)  
All measurements are in millimeters – All threads are BSP

### NIPPLO / NIPPLE

In polipropilene  
Made in polypropilene



<b>NIP 38</b>	<b>W</b>	3/8" M x 3/8" M	6 g	<b>cod. 04.25.13800</b>
<b>NIP 12</b>	<b>E</b>	1/2" M x 1/2" M	6 g	<b>cod. 04.25.11200</b>
<b>NIP 34</b>	<b>E</b>	3/4" M x 3/4" M	10 g	<b>cod. 04.25.13400</b>

### NIPPLO RIDOTTO / REDUCED NIPPLE

In polipropilene  
Made in polypropilene



<b>NIP 3812</b>	<b>E</b>	3/8" M x 1/2" M	6 g	<b>cod. 04.25.23812</b>
<b>NIP 1234</b>	<b>E</b>	1/2" M x 3/4" M	7 g	<b>cod. 04.25.21234</b>

### MANICOTTO F SOCKET

In polipropilene  
Made in polypropilene



<b>MAF 38</b>	<b>S</b>	3/8" F x 3/8" F	9 g	<b>cod. 04.30.23800</b>
<b>MAF 12</b>	<b>S</b>	1/2" F x 1/2" F	13 g	<b>cod. 04.30.21200</b>
<b>MAF 34</b>	<b>E</b>	3/4" F x 3/4" F	20 g	<b>cod. 04.30.23400</b>

### RACCORDO F A "T" / "T" F ADAPTORS

In polipropilene  
Made in polypropilene



<b>TIF 38</b>	<b>S</b>	3/8" F	14 g	<b>cod. 04.30.13800</b>
<b>TIF 12</b>	<b>E</b>	1/2" F	24 g	<b>cod. 04.30.11200</b>
<b>TIF 34</b>	<b>E</b>	3/4" F	36 g	<b>cod. 04.30.13400</b>

### GOMITO F ELBOW

In polipropilene  
Made in polypropilene



<b>GOF 38</b>	<b>S</b>	3/8" F x 3/8" F	11 g	<b>cod. 04.30.33800</b>
<b>GOF 12</b>	<b>E</b>	1/2" F x 1/2" F	17 g	<b>cod. 04.30.31200</b>
<b>GOF 34</b>	<b>S</b>	3/4" F x 3/4" F	26 g	<b>cod. 04.30.33400</b>
<b>GOF 10</b>	<b>W</b>	1" F x 1" F	56 g	<b>cod. 04.30.31000</b>

### GOMITO M-F ELBOW

In polipropilene  
Made in polypropilene



<b>GMF 12</b>	<b>E</b>	1/2" M x 1/2" F	23 g	<b>cod. 04.30.41200</b>
<b>GMF 34</b>	<b>E</b>	3/4" M x 3/4" F	35 g	<b>cod. 04.30.43400</b>



**RACCORDO A "Y" / "Y" ADAPTORS**

In polipropilene trasparente  
Made in clear polypropilene



<b>PY 10</b>	Ø 10 mm	3 g	<b>cod. 04.21.00010</b>
<b>PY 12</b>	Ø 12 mm	4 g	<b>cod. 04.21.00012</b>
<b>PY 14</b>	Ø 14 mm	5 g	<b>cod. 04.21.00014</b>
<b>PY 16</b>	Ø 16 mm	7 g	<b>cod. 04.21.00016</b>

**RACCORDO A "T" / "T" ADAPTORS**

In polipropilene rosso  
Made in red polypropilene



<b>PT 10</b>	Ø 10 mm	3 g	<b>cod. 04.21.10010</b>
<b>PT 12</b>	Ø 12 mm	4 g	<b>cod. 04.21.10012</b>
<b>PT 14</b>	Ø 14 mm	5 g	<b>cod. 04.21.10014</b>
<b>PT 16</b>	Ø 16 mm	6 g	<b>cod. 04.21.10016</b>
<b>PT 18</b>	Ø 18 mm	7 g	<b>cod. 04.21.10018</b>
<b>PT 20</b>	Ø 20 mm	8 g	<b>cod. 04.21.10020</b>
<b>PT 22</b>	Ø 22 mm	12 g	<b>cod. 04.21.10021</b>
<b>PT 25</b>	Ø 25 mm	16 g	<b>cod. 04.21.10025</b>

**OMBRINALI / SKIN FITTINGS**

In polipropilene bianco / In white polypropylene

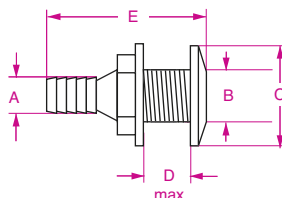

Articolo / Item	A	B	C	D	E	Peso / Weight	Code
<b>SM 58</b>	16 mm	22 mm	43 mm	28 mm	75 mm	18 g	<b>cod. 02.20.05800</b>
<b>SM 34</b>	19 mm	26 mm	51 mm	29 mm	82 mm	27 g	<b>cod. 02.20.03400</b>
<b>SM 10</b>	25 mm	32 mm	61 mm	32 mm	94 mm	49 g	<b>cod. 02.20.01000</b>
<b>SM 14</b>	32 mm	41 mm	68 mm	29 mm	98 mm	66 g	<b>cod. 02.20.01400</b>
<b>SM 15</b>	38 mm	47 mm	75 mm	31 mm	104 mm	81 g	<b>cod. 02.20.01500</b>
<b>SM 15-NRV*</b>	38 mm	47 mm	83 mm	31 mm	110 mm	117 g	<b>cod. 02.20.01501</b>

\*CON VALVOLA DI NON RITORNO / WITH NON RETURN VALVE

**RACCORDERIA IN OTTONE / BRASS FITTINGS**

**COLLETTORE / MANIFOLD**

con rubinetti / with taps



<b>COLT 122 M-B</b>	2 x 1/2" M	300 g	<b>cod. 04.55.21220</b>
<b>COLT 122 M-R</b>	2 x 1/2" M	300 g	<b>cod. 04.55.21221</b>
<b>COLT 123 M-B</b>	3 x 1/2" M	431 g	<b>cod. 04.55.21230</b>
<b>COLT 123 M-R</b>	3 x 1/2" M	431 g	<b>cod. 04.55.21231</b>
<b>COLT 124 M-B</b>	4 x 1/2" M	591 g	<b>cod. 04.55.21240</b>
<b>COLT 124 M-R</b>	4 x 1/2" M	591 g	<b>cod. 04.55.21241</b>

**COLLETTORE GIALLO / YELLOW MANIFOLD**



<b>COL 122 F</b>	2 x 1/2" F	188 g	<b>cod. 04.55.01220</b>
<b>COL 123 F</b>	3 x 1/2" F	281 g	<b>cod. 04.55.01230</b>
<b>COL 124 F</b>	4 x 1/2" F	353 g	<b>cod. 04.55.01240</b>
<b>COL 122 M</b>	4 x 1/2" M	162 g	<b>cod. 04.55.11220</b>
<b>COL 123 M</b>	4 x 1/2" M	225 g	<b>cod. 04.55.11230</b>
<b>COL 124 M</b>	4 x 1/2" M	299 g	<b>cod. 04.55.11240</b>

Tutte le misure sono espresse in millimetri – Tutti i filetti in BSP (GAS)  
All measurements are in millimeters – All threads are BSP

### PORTAGOMMA F HOSETAIL

In ottone giallo  
Yellow brass



<b>PGB 3812</b>	3/8" x 12	26 g	<b>cod. 04.51.03812</b>
<b>PGB 3814</b>	3/8" x 14		<b>cod. 04.51.03814</b>

### MANICOTTO F/F COUPLING

In ottone giallo  
Yellow brass



<b>MAB 38</b>	3/8"	36 g	<b>cod. 04.50.23800</b>
<b>MAB 12</b>	1/2"	49 g	<b>cod. 04.50.21200</b>
<b>MAB 34</b>	3/4"	74 g	<b>cod. 04.50.23400</b>
<b>MAB 10</b>	1"	116 g	<b>cod. 04.50.21000</b>

### GOMITO F/F ELBOW

In ottone giallo  
Yellow brass



<b>GOB 38</b>	3/8"		<b>cod. 04.50.33800</b>
<b>GOB 12</b>	1/2"	72 g	<b>cod. 04.50.31200</b>
<b>GOB 34</b>	3/4"		<b>cod. 04.50.33400</b>

### GOMITO M/F ELBOW

In ottone giallo  
Yellow brass



<b>GOB MF 38</b>	3/8"	60 g	<b>cod. 04.50.43800</b>
<b>GOB MF 12</b>	1/2"	96 g	<b>cod. 04.50.41200</b>

### RACCORDO F A "T" / "T" F CONNECTION

In ottone giallo  
Yellow brass



<b>TIB 38</b>	3/8"	96 g	<b>cod. 04.50.13800</b>
<b>TIB 12</b>	1/2"	99 g	<b>cod. 04.50.11200</b>
<b>TIB 34</b>	3/4"	167 g	<b>cod. 04.50.13400</b>
<b>TIB 10</b>	1"	274 g	<b>cod. 04.50.11000</b>

Tutte le misure sono espresse in millimetri – Tutti i filetti in BSP (GAS)  
All measurements are in millimeters – All threads are BSP

### NIPPLO / NIPPLE

In ottone giallo  
Yellow brass



<b>NIB 38</b>	3/8"	18 g	<b>cod. 04.51.13800</b>
<b>NIB 12</b>	1/2"	32 g	<b>cod. 04.51.11200</b>
<b>NIB 34</b>	3/4"	51 g	<b>cod. 04.51.13400</b>

### NIPPLO RIDOTTO / REDUCED NIPPLE

In ottone giallo  
Yellow brass



<b>NIB 1238</b>	1/2" x 3/8"	30 g	<b>cod. 04.51.21238</b>
<b>NIB 3412</b>	3/4" x 1/2"	48 g	<b>cod. 04.51.23412</b>
<b>NIB 1034</b>	1" x 3/4"	91 g	<b>cod. 04.51.21034</b>

### MANICOTTO RIDOTTO F/M REDUCED SOCKET

In ottone Nichelato  
Brass nichel plated



<b>MABFM 1238</b>	1/2" F x 3/8" M	27 g	<b>cod. 04.51.31238</b>
<b>MABFM 3412</b>	3/4" F x 1/2" M	43 g	<b>cod. 04.51.33412</b>

### MANICOTTO RIDOTTO F/F REDUCED SOCKET

In ottone Nichelato  
Brass nichel plated



<b>MAB 1238</b>	1/2" x 3/8"	44 g	<b>cod. 04.51.41238</b>
<b>MAB 3412</b>	3/4" x 1/2"	65 g	<b>cod. 04.51.43412</b>

### RIDUZIONE M/F REDUCTION

In ottone giallo  
Yellow brass



<b>RIBMF 1238</b>	1/2" x 3/8"	17 g	<b>cod. 04.51.51238</b>
<b>RIBMF 3412</b>	3/4" x 1/2"	32 g	<b>cod. 04.51.53412</b>

### GHIERA / RING

In ottone giallo  
Yellow brass



<b>GHB 1238</b>	1/2" M x 3/8" F	8 g	<b>cod. 04.51.61238</b>
-----------------	-----------------	-----	-------------------------



SUPPORTI TAVOLO & SUPPORTI POLTRONA / TABLE PEDESTALS & CHAIRS PEDESTALS

# TELESCOPICI / TELESCOPICS

## SUPPORTI TAVOLO ELETTRICI / ELECTRIC TABLE PEDESTALS

Costruiti in alluminio lucidato e anodizzato. Spinta 80 Kg - Velocità 16 mm/sec. Centralina elettronica di controllo inclusa.  
Built in polished, brightened and anodized light alloy. Push 80 Kg - Speed 16 mm/sec. Electronic control box included.

### TRE STADI / THREE STAGES

18893 > CORSA / STROKE 400 MM

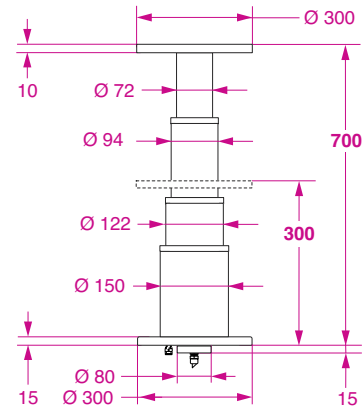

18893/12 12 Volt - 12 A

18893/24 24 Volt - 6 A

cod. 08.02.30012

cod. 08.02.30024

Tutte le misure sono espresse in mm / All measurements are in millimeters

# A DISCESA TOTALE / ALMOST FLUSH TO FLOOR TRE STADI / THREE STAGES

18693 > CORSA / STROKE 730 MM

TRE STADI / THREE STAGES

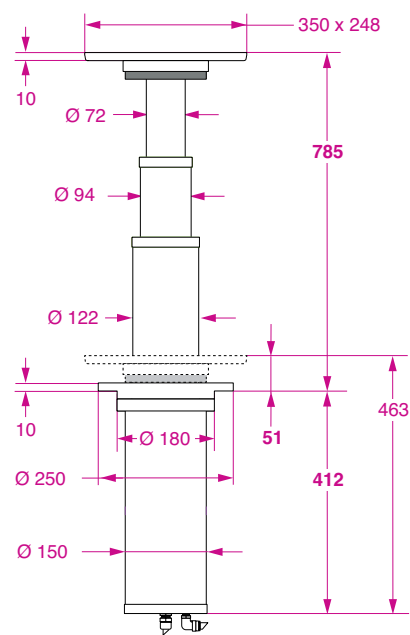

18693/12 12 Volt - 12 A

cod. 08.02.40012

18693/24 24 Volt - 6 A

cod. 08.02.40024

## DUE STADI / TWO STAGES

B18818 > CORSA / STROKE 350 MM

### Supporto a batteria senza cablaggi.

Autonomia più di 40 movimentazioni complete.  
Durata carica della batteria: 1 anno.  
Ricarica completa della batteria in 3 ore.  
Completo di telecomando e cavo per ricarica.

### Integrated Battery powered portable pedestal.

Raise & lower up to 40 times per charge.  
Battery lasts up to 1 year without use.  
Full recharge in less than 3 hours.  
Supplied with remote control and charging cable.

## BATTERIA INCORPORATA BATTERY INTEGRATED

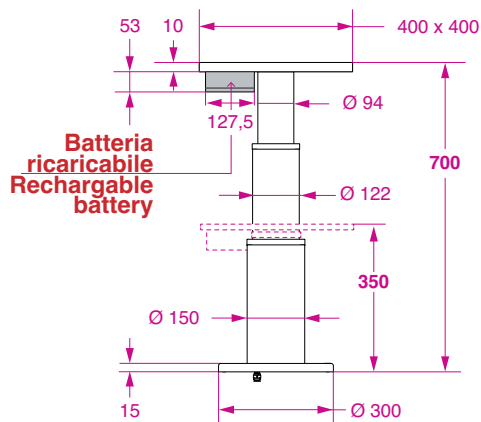

B18818

Peso / Weight 13,9 Kg

cod. 08.02.02001

Tutte le misure sono espresse in mm / All measurements are in millimeters



# TELESCOPICI / TELESCOPICS SUPPORTI TAVOLO ELETTRICI / ELECTRIC TABLE PEDESTALS

COSTRUITI IN ALLUMINIO LUCIDATO E ANODIZZATO  
MADE IN POLISHED, BRIGHTENED AND ANODIZED LIGHT ALLOY

DUE STADI / TWO STAGES

UNA GAMMA  
CON DIVERSE  
CORSE ED ALTEZZE  
A RANGE  
OF DIFFERENT STROKES  
AND HEIGHTS



Spinta 80 Kg - Velocità 16 mm/sec – Centralina elettronica di controllo inclusa.  
Push 80 Kg - Speed 16 mm/sec – Electronic control box included.

CORSA / STROKE  
**18498 400 MM**

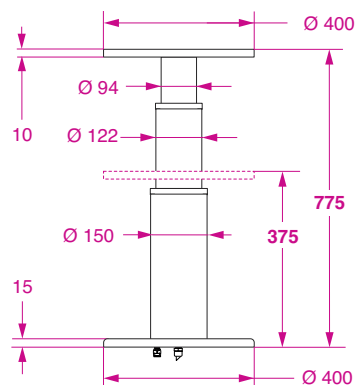

**18498/12** 12 Volt - 10 A **cod. 08.02.01350**  
**18498/24** 24 Volt - 5 A **cod. 08.02.01355**

CORSA / STROKE  
**18898 350 MM**

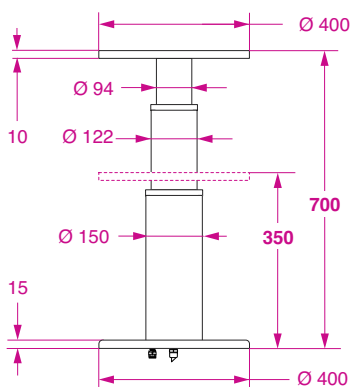

**18898/12** 12 Volt - 10 A **cod. 08.02.01212**  
**18898/24** 24 Volt - 5 A **Peso / Weight 15,9 Kg cod. 08.02.01224**

CORSA / STROKE  
**18598 500 MM**

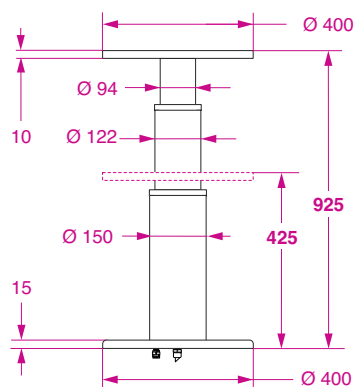

**18598/12** 12 Volt - 10 A **cod. 08.02.01360**  
**18598/24** 24 Volt - 5 A **cod. 08.02.01365**

Tutte le misure sono espresse in mm / All measurements are in millimeters

**1889N > TELESCOPICO A DUE STADI / TWO STAGES TELESCOPIC****FINITURA NERA LUCIDA**  
**BLACK POLISH FINISH****Costruzione in alluminio anodizzato nero.**

Alimentazione a 12V-10A o 24V-5A (a richiesta).  
Spinta 80 Kg - Velocità 16 mm/sec - corsa 350 mm.  
Centralina elettronica di controllo inclusa.

**Made in polished, black anodized light alloy.**

Powered with 12V-10A or 24V-5A (on request).  
Push 80 Kg - Speed 16 mm/sec - stroke 350 mm.  
Electronic control box included.

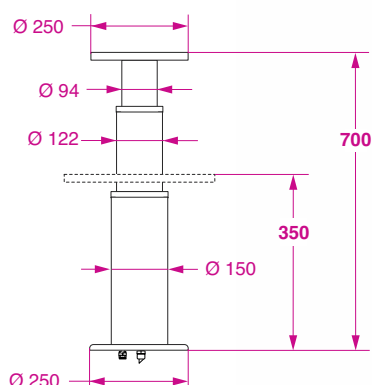
**1889N/12****1889N/24****cod. 08.02.01112****cod. 08.02.01114****18INOX > TELESCOPICO A UNO STADIO / ONE STAGE TELESCOPIC****COSTRUZIONE IN ACCIAIO INOX, LUCIDO A SPECCHIO**  
**MADE IN POLISHED STAINLESS STEEL**

Alimentazione a 12V-10A o 24V-5A (a richiesta).  
Spinta 80 Kg - Velocità 16 mm/sec - corsa 330 mm. Centralina elettronica di controllo inclusa.  
Azionato tramite un interruttore (non fornito) a 3 posizioni:  
SU - GIU e zero centrale con ritorno automatico.

Powered with 12V-10A or 24V-5A (on request).  
Push 80 Kg - Speed 16 mm/sec - stroke 330 mm. Electronic control box included.  
Operated with a 3 position switch (not supplied) (UP - DOWN and automatic return to zero).

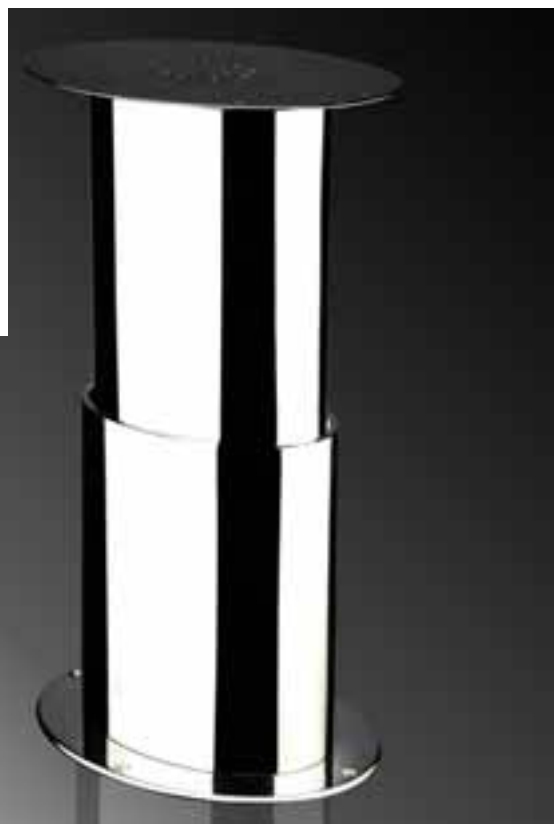
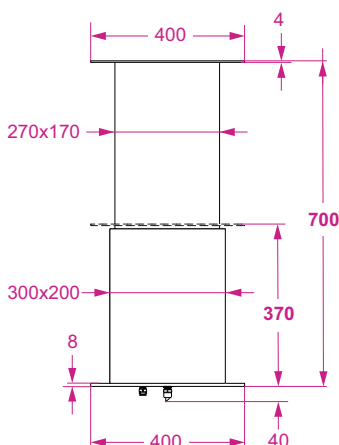
**18INOX/12** 12 Volt**18INOX/24** 24 Volt**cod. 08.02.00001****cod. 08.02.00002**

## SUPPORTI TAVOLO ELETTRICI / ELECTRIC TABLE PEDESTALS

### 18898/G > TELESCOPICO A DUE STADI / TWO STAGES TELESCOPIC



TESTA GIREVOLE  
SWIVEL HEAD

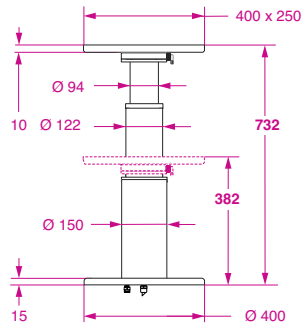

La testa ruota su 360°  
con sistema di blocco ogni 90°  
Spinta 80 Kg - Velocità 16 mm/sec - corsa 350 mm  
Centralina elettronica di controllo inclusa

The head can swivel on 360°  
and can be locked at 90° steps to allow  
to choose the best table position  
Push 80 Kg - Speed 16 mm/sec - stroke 350 mm  
Electronic control box included

18898/G/12 12 Volt - 10A

cod. 08.02.11212

18898/G/24 24 Volt - 5A

Peso / Weight 15,1 Kg

cod. 08.02.11224

### 188 HT > TELESCOPICO A DUE STADI / TWO STAGES TELESCOPIC

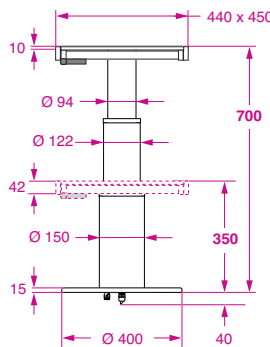

Con piastra superiore scorrevole,  
traslazione 200 mm  
per regolare distanza del tavolo dalla seduta  
Spinta 80 Kg - Velocità 16 mm/sec - corsa 350 mm  
Centralina elettronica di controllo inclusa

Sliding upper plate, 200 mm  
to adjust table distance from seating  
Push 80 Kg - Speed 16 mm/sec - stroke 350 mm  
Electronic control box included

188 HT/12 12 Volt - 10 A

cod. 08.02.11242

188 HT/24 24 Volt - 5 A

cod. 08.02.11244

### 189 HT/35/30 > TELESCOPICO A DUE STADI / TWO STAGES TELESCOPIC

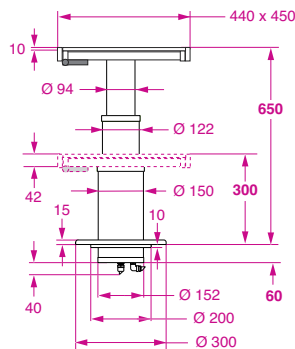

Con piastra superiore scorrevole,  
traslazione 200 mm  
per regolare distanza del tavolo dalla seduta  
Spinta 80 Kg - Velocità 16 mm/sec - Corsa 350 mm.  
Centralina elettronica di controllo inclusa.

Sliding upper plate, 200 mm  
to adjust table distance from seating  
Push 80 Kg - Speed 16 mm/sec - Stroke 350 mm.  
Electronic control box included.

189 HT/35/30/12 12 Volt - 10 A

cod. 08.02.21242

189 HT/35/30/24 24 Volt - 5 A

cod. 08.02.21244

### 189 HT/40/30 > TELESCOPICO A DUE STADI / TWO STAGES TELESCOPIC

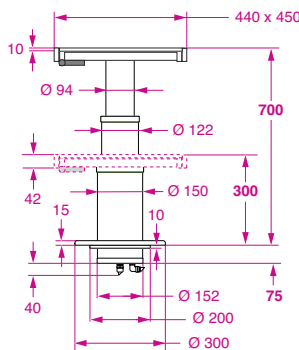

Con piastra superiore scorrevole,  
traslazione 200 mm  
per regolare distanza del tavolo dalla seduta  
Spinta 80 Kg - Velocità 16 mm/sec - Corsa 400 mm.  
Centralina elettronica di controllo inclusa.

Sliding upper plate, 200 mm  
to adjust table distance from seating  
Push 80 Kg - Speed 16 mm/sec - Stroke 400 mm.  
Electronic control box included.

189 HT/40/30/12 12 Volt - 10 A

cod. 08.02.21342

189 HT/40/30/24 24 Volt - 5 A

cod. 08.02.21344

Tutte le misure sono espresse in mm / All measurements are in millimeters

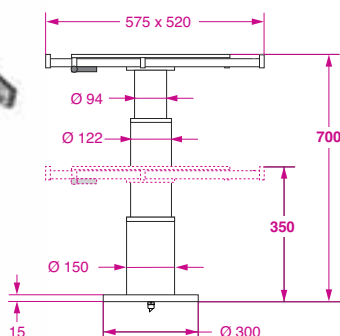
**18898 HT > TELESCOPICO A DUE STADI / TWO STAGES TELESCOPIC**

**Con supporto tavolo allungabile.**  
Spinta 80 Kg - Velocità 16 mm/sec - corsa 350 mm.  
Centralina elettronica di controllo inclusa.

**With table support with extensions.**  
Push 80 Kg - Speed 16 mm/sec - stroke 350 mm.  
Electronic control box included.

**18898 HT/12** 12 Volt - 10 A

**cod. 08.02.01251**

**18898 HT/24** 24 Volt - 5 A

Peso / Weight 19,3 Kg

**cod. 08.02.00051**

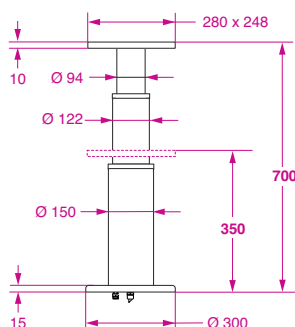
**18898 HB > TELESCOPICO A DUE STADI / TWO STAGES TELESCOPIC**

Spinta 80 Kg - Velocità 16 mm/sec - corsa 350 mm.  
Centralina elettronica di controllo inclusa.

Push 80 Kg - Speed 16 mm/sec - stroke 350 mm.  
Electronic control box included.

**18898HB/12** 12 Volt - 10 A

**cod. 08.02.01250**

**18898HB/24** 24 Volt - 5 A

Peso / Weight 11 Kg

**cod. 08.02.01248**

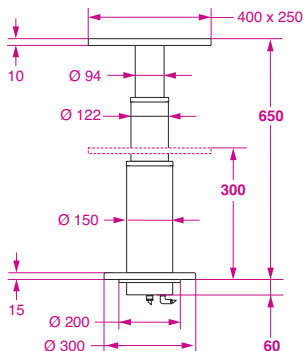
**18998/35/30 > TELESCOPICO A DUE STADI / TWO STAGES TELESCOPIC**

**Con sporgenza sotto pavimento.**  
Spinta 80 Kg - Velocità 16 mm/sec - corsa 350 mm.  
Centralina elettronica di controllo inclusa.

**With underfloor protrusion.**  
Push 80 Kg - Speed 16 mm/sec - stroke 350 mm.  
Electronic control box included.

**18998/35/30/12** 12 Volt - 10 A

**cod. 08.02.21212**

**18998/35/30/24** 24 Volt - 5 A

Peso / Weight 12,9 Kg

**cod. 08.02.21224**

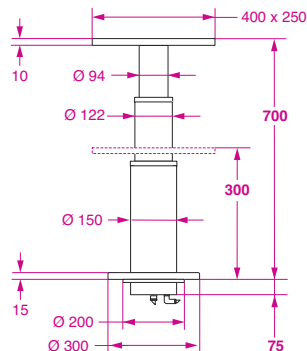
**18998/40/30 > TELESCOPICO A DUE STADI / TWO STAGES TELESCOPIC**

**Con sporgenza sotto pavimento.**  
Spinta 80 Kg - Velocità 16 mm/sec - corsa 400 mm.  
Centralina elettronica di controllo inclusa.

**With underfloor protrusion.**  
Push 80 Kg - Speed 16 mm/sec - stroke 400 mm.  
Electronic control box included.

**18998/40/30/12** 12 Volt - 10 A

**cod. 08.02.21312**

**18998/40/30/24** 24 Volt - 5 A

Peso / Weight 13,2 Kg

**cod. 08.02.21324**

Tutte le misure sono espresse in mm / All measurements are in millimeters

# SUPPORTI TAVOLO ELETTRICI ELECTRIC TABLE PEDESTALS

# DUE STADI / TWO STAGES

## 18697 > A SCOMPARSA > TELESCOPICO A DUE STADI / FLUSH > TWO STAGES TELESCOPICO

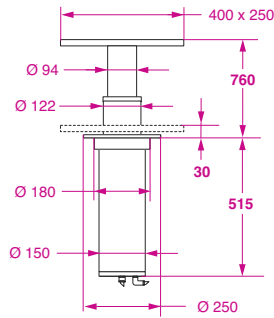

Spinta 80 Kg - Velocità 16 mm/sec - corsa 730 mm.  
Centralina elettronica di controllo inclusa.

Push 80 Kg - Speed 16 mm/sec - stroke 730 mm.  
Electronic control box included.

18697/12

12 Volt - 10 A

cod. 08.02.60012

18697/24

24 Volt - 5 A

Peso / Weight 15,9 Kg

cod. 08.02.60024

## 18697/80 > A SCOMPARSA > TELESCOPICO A DUE STADI / FLUSH > TWO STAGES TELESCOPICO

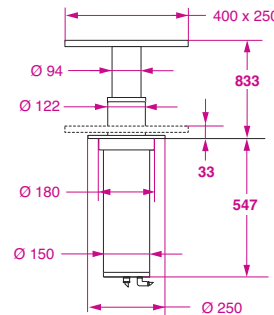

Spinta 80 Kg - Velocità 16 mm/sec - corsa 800 mm.  
Centralina elettronica di controllo inclusa.

Push 80 Kg - Speed 16 mm/sec - stroke 800 mm.  
Electronic control box included.

18697/80/12

12 Volt - 10 A

cod. 08.02.60212

18697/80/24

24 Volt - 5 A

Peso / Weight 18 Kg

cod. 08.02.60224

## 18697/G > A SCOMPARSA > TELESCOPICO A DUE STADI / FLUSH > TWO STAGES TELESCOPICO



**TESTA GIREVOLE  
SWIVEL HEAD**

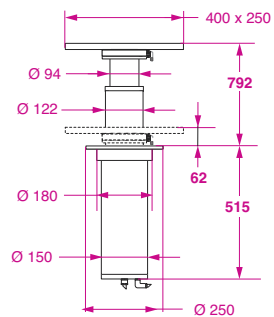

**La testa ruota su 360°,  
con sistema di blocco ogni 90°.**  
Spinta 80 Kg - Velocità 16 mm/sec - corsa 730 mm.  
Centralina elettronica di controllo inclusa.

**The head can swivel on 360°  
and can be locked at 90° steps  
to allow to choose the best table position.**  
Push 80 Kg - Speed 16 mm/sec - stroke 730 mm.  
Electronic control box included.

18697/G/12

12 Volt - 10 A

cod. 08.02.60112

18697/G/24

24 Volt - 5 A

Peso / Weight 18 Kg

cod. 08.02.60124

Particolare testa girevole  
Detail swiveling head

La testa girevole su 360° e bloccabile in qualunque posizione,  
consente di variare a piacere la posizione del tavolo.  
The head can swivel on 360° and can be locked in any position to  
allow to choose at will the table position.

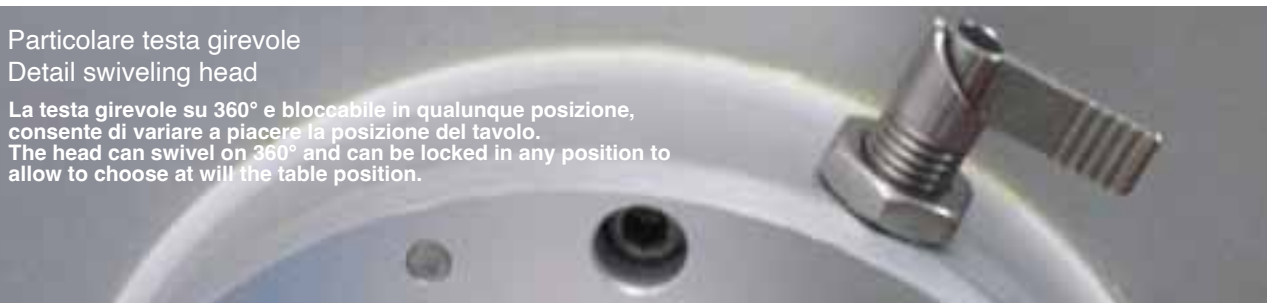





UNA GAMMA  
A DISCESA  
TOTALE  
A RANGE  
ALMOST  
FLUSH  
TO FLOOR

UNO STADIO  
ONE STAGE

**19697 > A SCOMPARSA > TELESCOPICO A UNO STADIO / FLUSH > ONE STAGE TELESCOPICO**

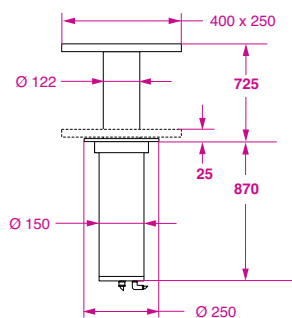

Spinta 80 Kg - Velocità 16 mm/sec - corsa 700 mm.  
Centralina elettronica di controllo inclusa.

Push 80 Kg - Speed 16 mm/sec - stroke 700 mm.  
Electronic control box included.

19697/12

12 Volt - 8 A

cod. 08.02.70012

19697/24

24 Volt - 4 A

Peso / Weight 17,6 Kg

cod. 08.02.70024

**18191/65 > A SCOMPARSA > TELESCOPICO A UNO STADIO / FLUSH > ONE STAGE TELESCOPICO**

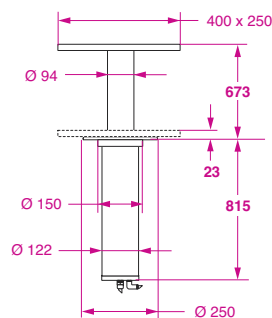

Spinta 80 Kg - Velocità 16 mm/sec - corsa 650 mm.  
Centralina elettronica di controllo inclusa.

Push 80 Kg - Speed 16 mm/sec - stroke 650 mm.  
Electronic control box included.

18191/65/12

12 Volt - 8 A

cod. 08.08.70112

18191/65/24

24 Volt - 4 A

cod. 08.08.70124

**18191/70 > A SCOMPARSA > TELESCOPICO A UNO STADIO / FLUSH > ONE STAGE TELESCOPICO**

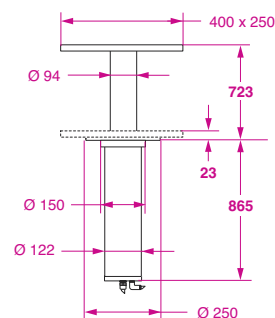

Spinta 80 Kg - Velocità 16 mm/sec - corsa 700 mm.  
Centralina elettronica di controllo inclusa.

Push 80 Kg - Speed 16 mm/sec - stroke 700 mm.  
Electronic control box included.

18191/70/12

12 Volt - 8 A

cod. 08.08.71112

18191/70/24

24 Volt - 4 A

cod. 08.08.71124

## SUPPORTI TAVOLO ELETTRICI / ELECTRIC TABLE PEDESTALS

### 19898 > TELESCOPICO A DUE STADI / TWO STAGES TELESCOPIC

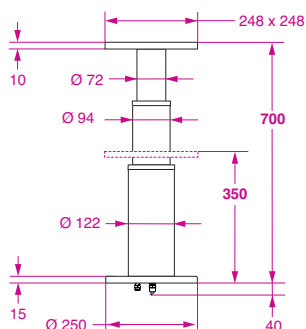

Corsa 350 mm.  
Centralina elettronica di controllo inclusa.

Stroke 350 mm.  
Electronic control box included.

**19898/12** 12 Volt - 10 A  
**19898/24** 24 Volt - 5 A

**cod. 08.02.11012**  
**cod. 08.02.11024**

### 17998/40/30 > TELESCOPICO A DUE STADI / TWO STAGES TELESCOPIC

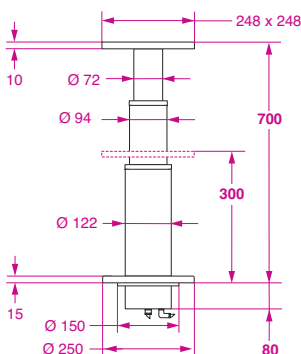

**Con sporgenza sotto pavimento.**  
Corsa 400 mm.  
Centralina elettronica di controllo inclusa.

**With underfloor protrusion.**  
Stroke 400 mm.  
Electronic control box included.

**17998/40/30/12** 12 Volt - 10 A  
**17998/40/30/24** 24 Volt - 5 A

**cod. 08.02.20012**  
**cod. 08.02.20024**

## MULTIPLI / MULTIPLE LEGS

### TELESCOPICO A DUE STADI / TWO STAGES TELESCOPIC



Peso  
Weight  
28 Kg

E18899

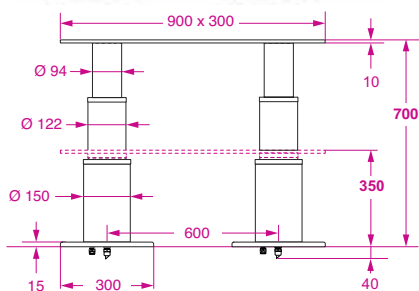

E188983

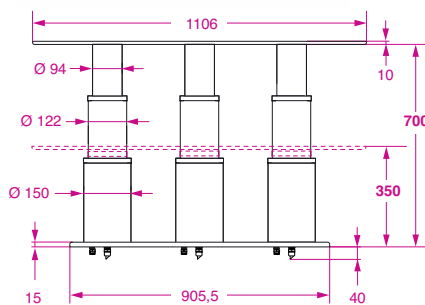

E188984

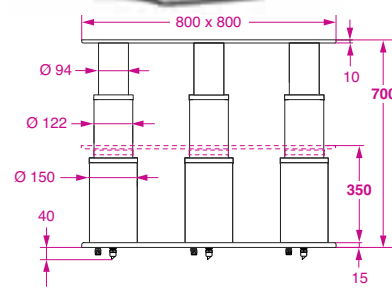

**E18899/12** 12 Volt - 10 A (x2)  
**E18899/24** 24 Volt - 5 A (x2)  
**E188983/12** 12 Volt - 10 A (x3)  
**E188983/24** 24 Volt - 5 A (x3)  
**E188984/12** 12 Volt - 10 A (x4)  
**E188984/24** 24 Volt - 5 A (x4)

Spinta 160 Kg - 240 Kg - 320 Kg  
Velocità 16 mm/sec - corsa 350 mm.  
Centralina elettronica di controllo inclusa,  
con tastiera di regolazione e movimentazione.  
Push 160 Kg - 240 Kg - 320 Kg  
Speed 16 mm/sec - stroke 350 mm.  
Electronic control box and keyboard for set-up  
and movement included.

**cod. 08.02.01312**  
**cod. 08.02.01324**  
**cod. 08.02.01412**  
**cod. 08.02.01424**  
**cod. 08.02.01512**  
**cod. 08.02.01524**

Con encoder

With encoder

Tutte le misure sono espresse in mm / All measurements are in millimeters

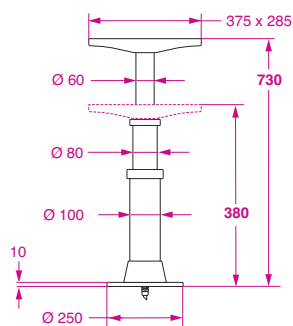
**12398 > TELESCOPICO A DUE STADI / TWO STAGES TELESCOPIC**

Spinta 80 Kg - Velocità 16 mm/sec - corsa 350 mm.  
Centralina elettronica di controllo inclusa.

Push 80 Kg - Speed 16 mm/sec - stroke 350 mm.  
Electronic control box included.

**12398/12** 12 Volt - 10 A

**cod. 08.01.00212**

**12398/24** 24 Volt - 5 A

Peso / Weight 9 Kg

**cod. 08.01.00224**

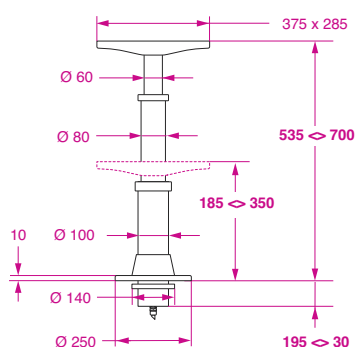
**12398/35 > TELESCOPICO A DUE STADI / TWO STAGES TELESCOPIC**

**Con sporgenza sotto pavimento regolabile.  
La posizione della base inferiore  
può essere regolata lungo il tubo inferiore  
per ottenere l'altezza appropriata.**

Spinta 80 Kg - Velocità 16 mm/sec - corsa 350 mm.  
Centralina elettronica di controllo inclusa.

**With underfloor adjustable protrusion.  
The position of the bottom base can be adjusted  
along the lower tube to get the appropriate height.**  
Push 80 Kg - Speed 16 mm/sec - stroke 350 mm.  
Electronic control box included.

**12398/35/12** 12 Volt - 10 A

**cod. 08.01.01212**

**12398/35/24** 24 Volt - 5 A

Peso / Weight 9,1 Kg

**cod. 08.01.01224**

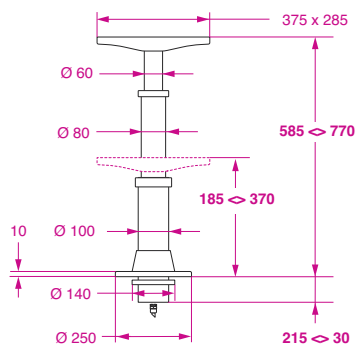
**12398/40 > TELESCOPICO A DUE STADI / TWO STAGES TELESCOPIC**

**Con sporgenza sotto pavimento regolabile.  
La posizione della base inferiore  
può essere regolata lungo il tubo inferiore  
per ottenere l'altezza appropriata.**

Spinta 80 Kg - Velocità 16 mm/sec - corsa 400 mm.  
Centralina elettronica di controllo inclusa.

**With underfloor adjustable protrusion.  
The position of the bottom base can be adjusted  
along the lower tube to get the appropriate height.**  
Push 80 Kg - Speed 16 mm/sec - stroke 400 mm.  
Electronic control box included.

**12398/40/12** 12 Volt - 10 A

**cod. 08.01.01312**

**12398/40/24** 24 Volt - 5 A

Peso / Weight 9,4 Kg

**cod. 08.01.01324**

**ATTENZIONE!**

**NON utilizzare sistemi di pulizia con acqua in pressione:  
potrebbero causare infiltrazioni e conseguenti malfunzionamenti dei supporti elettrici.  
Barka non garantisce i supporti sottoposti a pulizia con acqua in pressione.**

**CAUTION!**

**DO NOT PRESSURE WASH electric pedestals. Pedestals must NOT be subjected  
to water pressure because they may experience water intrusion and subsequent failure.  
Pressure washing will invalidate the warranty for those products.**

Tutte le misure sono espresse in mm / All measurements are in millimeters

## SUPPORTI TAVOLO ELETTRICI / ELECTRIC TABLE PEDESTALS

### 18198 > TELESCOPICO A UNO STADIO / ONE STAGE TELESCOPIC

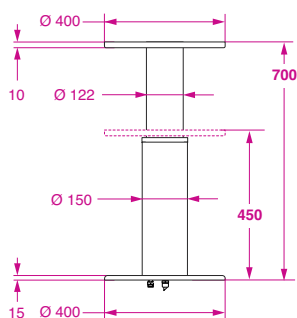

Spinta 80 Kg - Velocità 16 mm/sec - corsa 250 mm.  
Centralina elettronica di controllo inclusa.

Push 80 Kg - Speed 16 mm/sec - stroke 250 mm.  
Electronic control box included.

18198/12 12 Volt - 8 A

cod. 08.02.00012

18198/24 24 Volt - 4 A

Peso / Weight 15,5 Kg

cod. 08.02.00024

### 18398 > TELESCOPICO A UNO STADIO / ONE STAGE TELESCOPIC

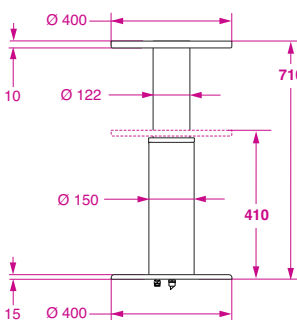

Spinta 80 Kg - Velocità 16 mm/sec - corsa 300 mm.  
Centralina elettronica di controllo inclusa.

Push 80 Kg - Speed 16 mm/sec - stroke 300 mm.  
Electronic control box included.

18398/12 12 Volt - 10 A

cod. 08.02.00112

18398/24 24 Volt - 5 A

Peso / Weight 15 Kg

cod. 08.02.00124

### 18298 > TELESCOPICO A UNO STADIO / ONE STAGE TELESCOPIC

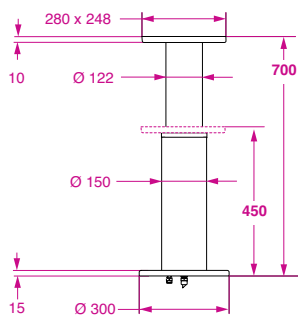

Spinta 80 Kg - Velocità 16 mm/sec - corsa 250 mm.  
Centralina elettronica di controllo inclusa.

Push 80 Kg - Speed 16 mm/sec - stroke 250 mm.  
Electronic control box included.

18298/12 12 Volt - 8 A

cod. 08.02.00030

18298/24 24 Volt - 4 A

cod. 08.02.00035

### 18197 > TELESCOPICO A UNO STADIO / ONE STAGE TELESCOPIC

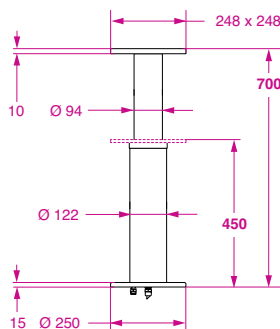

Spinta 80 Kg - Velocità 16 mm/sec - corsa 250 mm.  
Centralina elettronica di controllo inclusa.

Push 80 Kg - Speed 16 mm/sec - stroke 250 mm.  
Electronic control box included.

18197/12 12 Volt - 8 A

cod. 08.03.00012

18197/24 24 Volt - 4 A

Peso / Weight 8,7 Kg

cod. 08.03.00024

Tutte le misure sono espresse in mm / All measurements are in millimeters

# CON SPORGENZA SOTTO PAVIMENTO REGOLABILE WITH UNDERFLOOR ADJUSTABLE PROTRUSION

**18997/40/30 > TELESCOPICO A UNO STADIO / ONE STAGE TELESCOPIC**

Spinta 80 Kg  
Velocità 16 mm/sec  
Corso 400 mm.  
Centralina elettronica di controllo inclusa.

Push 80 Kg  
Speed 16 mm/sec  
Stroke 400 mm.  
Electronic control box included.

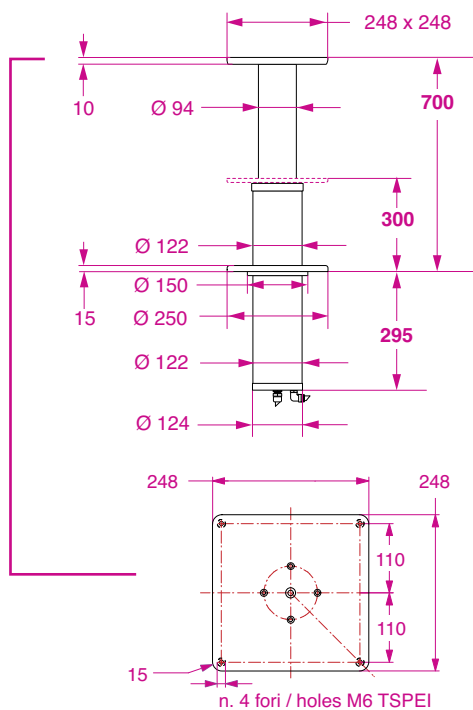

18997/40/30/12

12 Volt - 8 A

cod. 08.03.00112

18997/40/30/24

24 Volt - 4 A

cod. 08.03.00124

Tutte le misure sono espresse in mm / All measurements are in millimeters



## SUPPORTI TAVOLO ELETTRICI / ELECTRIC TABLE PEDESTALS

### 12197 > TELESCOPICO A UNO STADIO / ONE STAGE TELESCOPIC

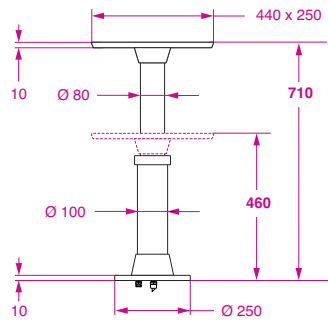

Spinta 80 Kg - Velocità 16 mm/sec - corsa 250 mm.  
Centralina elettronica di controllo inclusa.

Push 80 Kg - Speed 16 mm/sec - stroke 250 mm.  
Electronic control box included.

12197/12 12 Volt - 8 A  
12197/24 24 Volt - 4 A

Peso / Weight 10,6 Kg

cod. 08.05.00012  
cod. 08.05.00024

### 12197/G > TELESCOPICO A UNO STADIO / ONE STAGE TELESCOPIC

TESTA GIREVOLE  
SWIVEL HEAD

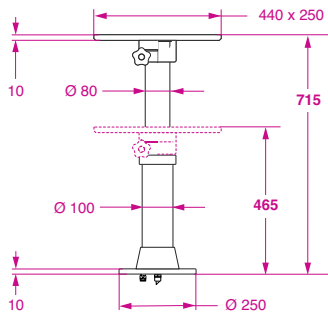

**Testa girevole su 360°  
e bloccabile in qualunque posizione.**  
Spinta 80 Kg - Velocità 16 mm/sec - corsa 250 mm.  
Centralina elettronica di controllo inclusa.

**The head can swivel on 360°  
and can be locked in any position.**  
Push 80 Kg - Speed 16 mm/sec - stroke 250 mm.  
Electronic control box included.

12197/G/12 12 Volt - 8 A  
12197/G/24 24 Volt - 4 A

Peso / Weight 11,4 Kg

cod. 08.05.10012  
cod. 08.05.10024

### 12198 > TELESCOPICO A UNO STADIO / ONE STAGE TELESCOPIC

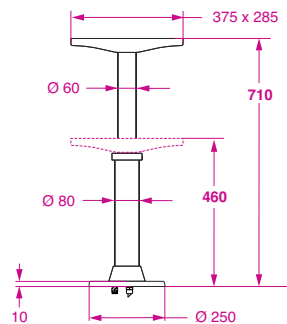

Spinta 80 Kg - Velocità 16 mm/sec - corsa 250 mm.  
Centralina elettronica di controllo inclusa.

Push 80 Kg - Speed 16 mm/sec - stroke 250 mm.  
Electronic control box included.

12198/12 12 Volt - 8 A  
12198/24 24 Volt - 4 A

Peso / Weight 6,9 Kg

cod. 08.05.20012  
cod. 08.05.20024

### 12199 > TELESCOPICO A UNO STADIO / ONE STAGE TELESCOPIC



Peso  
Weight  
8,4 Kg

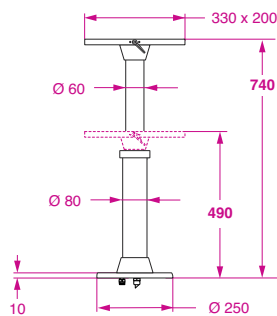

Spinta 80 Kg - Velocità 16 mm/sec - corsa 250 mm.  
Centralina elettronica di controllo inclusa.

Push 80 Kg - Speed 16 mm/sec - stroke 250 mm.  
Electronic control box included.

12199/12 12 Volt - 8 A  
12199/24 24 Volt - 4 A

cod. 08.05.30012  
cod. 08.05.30024

Tutte le misure sono espresse in mm / All measurements are in millimeters

# CON SPORGENZA SOTTO PAVIMENTO REGOLABILE WITH UNDERFLOOR ADJUSTABLE PROTRUSION

## 12297/35 > TELESCOPICO A UNO STADIO / ONE STAGE TELESCOPIC

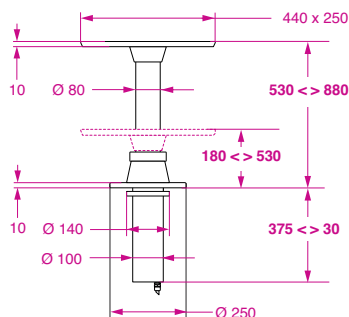

**Con sporgenza sotto pavimento regolabile.**  
Spinta 80 Kg - Velocità 16 mm/sec - corsa 350 mm.  
Centralina elettronica di controllo inclusa.

**With underfloor adjustable protrusion.**  
Push 80 Kg - Speed 16 mm/sec - stroke 350 mm.  
Electronic control box included.

12297/35/12

12 Volt - 8 A

cod. 08.05.01212

12297/35/24

24 Volt - 4 A

Peso / Weight 11 Kg

cod. 08.05.01224

## 12297/35/G > TELESCOPICO A UNO STADIO / ONE STAGE TELESCOPIC

TESTA GIREVOLE  
SWIVEL HEAD

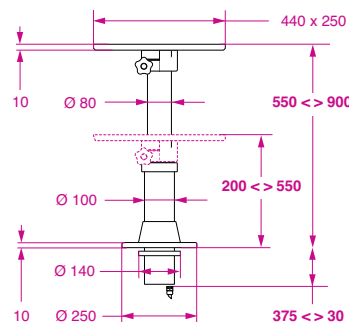

**Con sporgenza sotto pavimento regolabile  
e testa girevole su 360°.**  
Spinta 80 Kg - Velocità 16 mm/sec - corsa 350 mm.  
Centralina elettronica di controllo inclusa.

**With underfloor adjustable protrusion  
and swivel head on 360°.**  
Push 80 Kg - Speed 16 mm/sec - stroke 350 mm.  
Electronic control box included.

12297/35/G/12

12 Volt - 8 A

cod. 08.05.11212

12297/35/G/24

24 Volt - 4 A

Peso / Weight 11,8 Kg

cod. 08.05.11224

## 12297/40 > TELESCOPICO A UNO STADIO / ONE STAGE TELESCOPIC

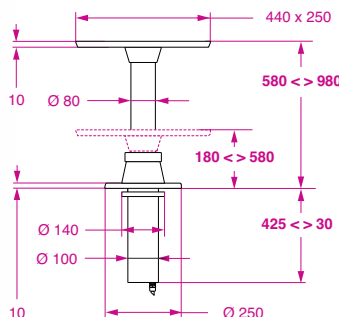

**Con sporgenza sotto pavimento regolabile.**  
Spinta 80 Kg - Velocità 16 mm/sec - corsa 400 mm.  
Centralina elettronica di controllo inclusa.

**With underfloor adjustable protrusion.**  
Push 80 Kg - Speed 16 mm/sec - stroke 400 mm.  
Electronic control box included.

12297/40/12

12 Volt - 8 A

cod. 08.05.01312

12297/40/24

24 Volt - 4 A

Peso / Weight 11,3 Kg

cod. 08.05.01324

## 12297/40/G > TELESCOPICO A UNO STADIO / ONE STAGE TELESCOPIC

TESTA GIREVOLE  
SWIVEL HEAD

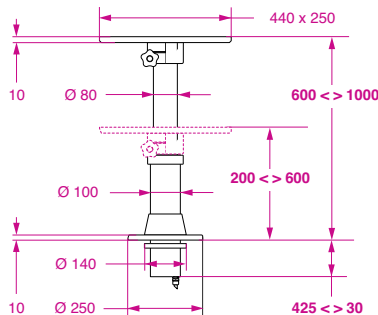

**Con sporgenza sotto pavimento regolabile  
e testa girevole su 360°.**  
Spinta 80 Kg - Velocità 16 mm/sec - corsa 400 mm.  
Centralina elettronica di controllo inclusa.

**With underfloor adjustable protrusion  
and swivel head on 360°.**  
Push 80 Kg - Speed 16 mm/sec - stroke 400 mm.  
Electronic control box included.

12297/40/G/12

12 Volt - 8 A

cod. 08.05.11312

12297/40/G/24

24 Volt - 4 A

Peso / Weight 12 Kg

cod. 08.05.11324

Tutte le misure sono espresse in mm / All measurements are in millimeters

## SUPPORTI TAVOLO ELETTRICI / ELECTRIC TABLE PEDESTALS

### 12298/35 > TELESCOPICO A UNO STADIO / ONE STAGE TELESCOPIC

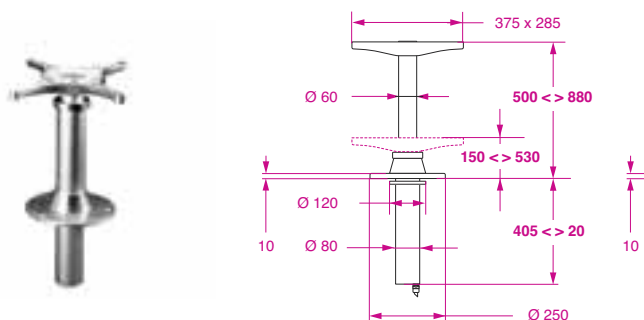

Con sporgenza sotto pavimento regolabile.  
In fase di montaggio la base può scorrere lungo il tubo inferiore per variare l'altezza minima.  
Spinta 80 Kg - Velocità 16 mm/sec - corsa 350 mm.  
Centralina elettronica di controllo inclusa.

With underfloor adjustable protrusion.  
The position of the bottom base can be adjusted along the lower tube to get the appropriate height.  
Push 80 Kg - Speed 16 mm/sec - stroke 350 mm.  
Electronic control box included.

12298/35/12 12 Volt - 8 A

cod. 08.05.21212

12298/35/24 24 Volt - 4 A

Peso / Weight 8,2 Kg

cod. 08.05.21224

### 12298/40 > TELESCOPICO A UNO STADIO / ONE STAGE TELESCOPIC

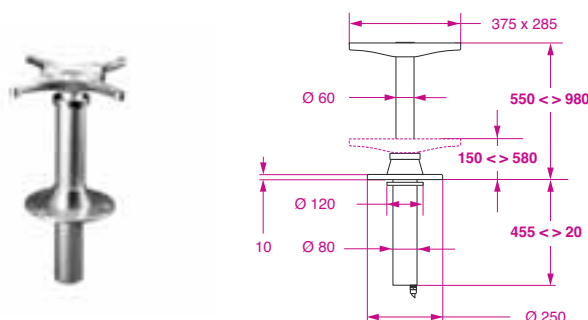

Con sporgenza sotto pavimento regolabile.  
In fase di montaggio la base può scorrere lungo il tubo inferiore per variare l'altezza minima.  
Spinta 80 Kg - Velocità 16 mm/sec - corsa 400 mm.  
Centralina elettronica di controllo inclusa.

With underfloor adjustable protrusion.  
The position of the bottom base can be adjusted along the lower tube to get the appropriate height.  
Push 80 Kg - Speed 16 mm/sec - stroke 400 mm.  
Electronic control box included.

12298/40/12 12 Volt - 8 A

cod. 08.05.21312

12298/40/24 24 Volt - 4 A

Peso / Weight 8,6 Kg

cod. 08.05.21324

### 12299/35 > TELESCOPICO A UNO STADIO / ONE STAGE TELESCOPIC

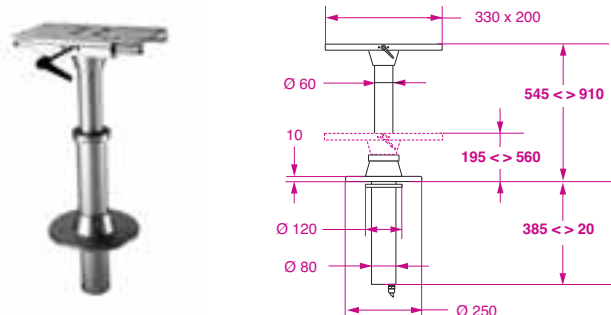

Con sporgenza sotto pavimento regolabile.  
In fase di montaggio la base può scorrere lungo il tubo inferiore per variare l'altezza minima.  
Spinta 80 Kg - Velocità 16 mm/sec - corsa 350 mm.  
Centralina elettronica di controllo inclusa.

With underfloor adjustable protrusion.  
The position of the bottom base can be adjusted along the lower tube to get the appropriate height.  
Push 80 Kg - Speed 16 mm/sec - stroke 350 mm.  
Electronic control box included.

12299/35/12 12 Volt - 8 A

cod. 08.05.31212

12299/35/24 24 Volt - 4 A

Peso / Weight 8,7 Kg

cod. 08.05.31224

### 12299/40 > TELESCOPICO A UNO STADIO / ONE STAGE TELESCOPIC

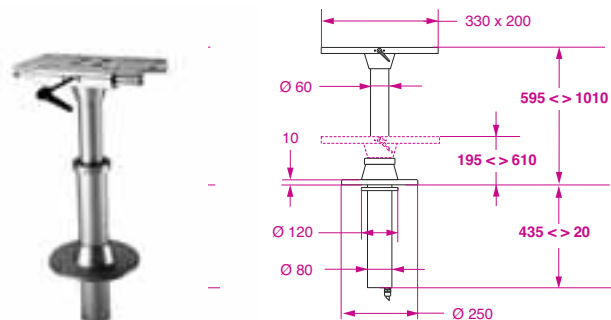

Con sporgenza sotto pavimento regolabile.  
In fase di montaggio la base può scorrere lungo il tubo inferiore per variare l'altezza minima.  
Spinta 80 Kg - Velocità 16 mm/sec - corsa 400 mm.  
Centralina elettronica di controllo inclusa.

With underfloor adjustable protrusion.  
The position of the bottom base can be adjusted along the lower tube to get the appropriate height.  
Push 80 Kg - Speed 16 mm/sec - stroke 400 mm.  
Electronic control box included.

12299/40/12 12 Volt - 8 A

cod. 08.05.31312

12299/40/24 24 Volt - 4 A

Peso / Weight 9,1 Kg

cod. 08.05.31324

Tutte le misure sono espresse in mm / All measurements are in millimeters

**12197/F > TELESCOPICO A UNO STADIO / ONE STAGE TELESCOPIC**

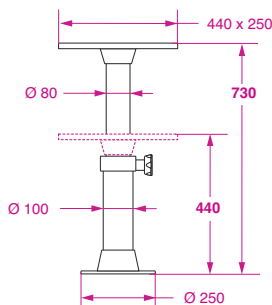

**12197/F**

Peso / Weight 8,2 Kg

Spinta 30 Kg - Corsa 290 mm. **Il pistone può essere bloccato in ogni posizione intermedia. A manopola sbloccata può ruotare su 360°.**

Push of 30 Kg - Stroke of 290 mm. **The piston can be locked in any intermediate position. When the handle is loose the top can rotate over 360°.**

**cod. 08.10.00000**

**12193 > TELESCOPICO A UNO STADIO / ONE STAGE TELESCOPIC**

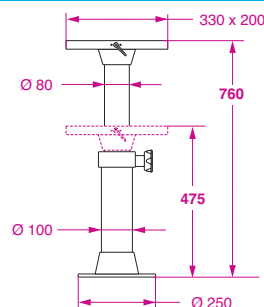

**12193**

Peso / Weight 8,3 Kg

Spinta 30 Kg - Corsa 285 mm. **Il pistone può essere bloccato in ogni posizione intermedia. A manopola sbloccata può ruotare su 360°.**

Push of 30 Kg - Stroke of 285 mm. **The piston can be locked in any intermediate position. When the handle is loose the top can rotate over 360°.**

**cod. 08.10.00005**

**10103/F/30 > TELESCOPICO A UNO STADIO / ONE STAGE TELESCOPIC**

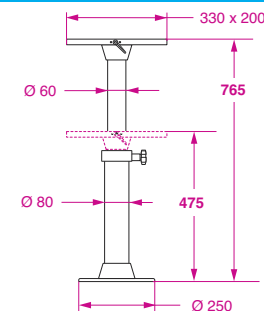

**10103/F/30**

Peso / Weight 6,7 Kg

Spinta 30 Kg - Corsa 290 mm. **Il pistone può essere bloccato in ogni posizione intermedia. A manopola sbloccata può ruotare su 360°.**

Push of 30 Kg - Stroke of 290 mm. **The piston can be locked in any intermediate position. When the handle is loose the top can rotate over 360°.**

**cod. 08.10.40200**

**10101/F/30 > TELESCOPICO A UNO STADIO / ONE STAGE TELESCOPIC**

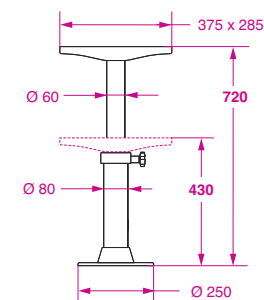

**10101/F/30**

Peso / Weight 6 Kg

Spinta 30 Kg - Corsa 290 mm. **Il pistone può essere bloccato in ogni posizione intermedia. A manopola sbloccata può ruotare su 360°.**

Push of 30 Kg - Stroke of 290 mm. **The piston can be locked in any intermediate position. When the handle is loose the top can rotate over 360°.**

**cod. 08.10.30100**

**10101/F/35 > TELESCOPICO A UNO STADIO / ONE STAGE TELESCOPIC**

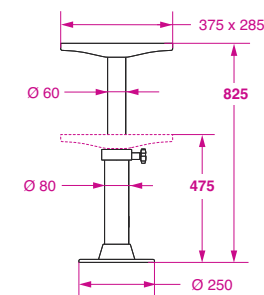

**10101/F/35**

Peso / Weight 6 Kg

Spinta 30 Kg - Corsa 350 mm. **Il pistone può essere bloccato in ogni posizione intermedia. A manopola sbloccata può ruotare su 360°.**

Push of 30 Kg - Stroke of 350 mm. **The piston can be locked in any intermediate position. When the handle is loose the top can rotate over 360°.**

**cod. 08.10.30200**

Tutte le misure sono espresse in mm / All measurements are in millimeters

## SUPPORTI TAVOLO A GAS GAS POWERED TABLE PEDESTALS

FISSI / FIXED

### 10199/30 > TELESCOPICO A UNO STADIO / ONE STAGE TELESCOPIC

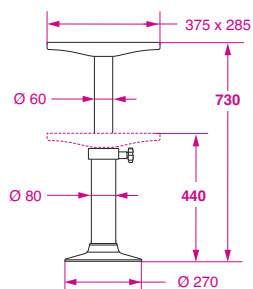

Spinta 30 Kg - Corsa 290 mm.  
**Il pistone può essere bloccato in ogni posizione intermedia.**  
A manopola sbloccata può ruotare su 360°.

Push of 30 Kg - Stroke of 290 mm.  
**The piston can be locked in any intermediate position.**  
When the handle is loose the top can rotate over 360°.

10199/30

Peso / Weight 4,5 Kg

cod. 08.16.33100

### 10199/35 > TELESCOPICO A UNO STADIO / ONE STAGE TELESCOPIC

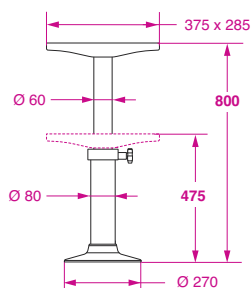

Spinta 30 Kg - Corsa 325 mm.  
**Il pistone può essere bloccato in ogni posizione intermedia.**  
A manopola sbloccata può ruotare su 360°.

Push of 30 Kg - Stroke of 325 mm.  
**The piston can be locked in any intermediate position.**  
When the handle is loose the top can rotate over 360°.

10199/35

Peso / Weight 4,7 Kg

cod. 08.16.33200

### 10298/30 > TELESCOPICO A UNO STADIO / ONE STAGE TELESCOPIC

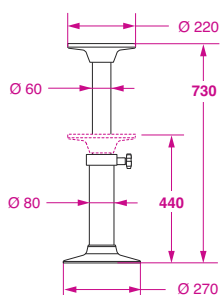

Spinta 30 Kg - Corsa 290 mm.  
**Il pistone può essere bloccato in ogni posizione intermedia.**  
A manopola sbloccata può ruotare su 360°.

Push of 30 Kg - Stroke of 290 mm.  
**The piston can be locked in any intermediate position.**  
When the handle is loose the top can rotate over 360°.

10298/30

Peso / Weight 4,6 Kg

cod. 08.16.53100

### 10298/35 > TELESCOPICO A UNO STADIO / ONE STAGE TELESCOPIC

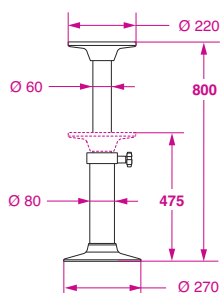

Spinta 30 Kg - Corsa 325 mm.  
**Il pistone può essere bloccato in ogni posizione intermedia.**  
A manopola sbloccata può ruotare su 360°.

Push of 30 Kg - Stroke of 325 mm.  
**The piston can be locked in any intermediate position.**  
When the handle is loose the top can rotate over 360°.

10298/35

Peso / Weight 4,7 Kg

cod. 08.16.53200

Tutte le misure sono espresse in mm / All measurements are in millimeters



## 10103/R/35 > TELESCOPICO A UNO STADIO / ONE STAGE TELESCOPIC

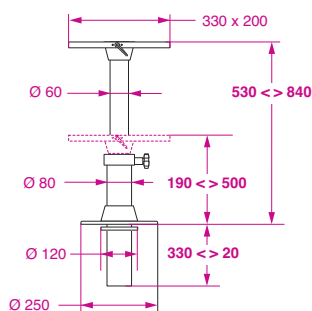

Il pistone può essere bloccato in ogni posizione intermedia. A manopola sbloccata può ruotare su 360°. In fase di montaggio la base può scorrere lungo il tubo inferiore per variare l'altezza minima. Spinta 30 Kg - Corsa 340 mm.

The piston can be locked in any intermediate position. When the handle is loose the top can rotate over 360°. The position of the bottom base can be adjusted along the lower tube to get the appropriate height. Push of 30 Kg - Stroke of 340 mm.

10103/R/35

Peso / Weight 6,5 Kg

cod. 08.10.41200

## 10103/R/40 > TELESCOPICO A UNO STADIO / ONE STAGE TELESCOPIC

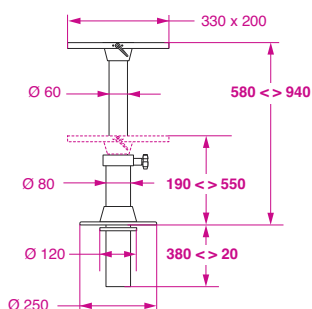

Il pistone può essere bloccato in ogni posizione intermedia. A manopola sbloccata può ruotare su 360°. In fase di montaggio la base può scorrere lungo il tubo inferiore per variare l'altezza minima. Spinta 30 Kg - Corsa 390 mm.

The piston can be locked in any intermediate position. When the handle is loose the top can rotate over 360°. The position of the bottom base can be adjusted along the lower tube to get the appropriate height. Push of 30 Kg - Stroke of 390 mm.

10103/R/40

Peso / Weight 6,9 Kg

cod. 08.10.41300

## 10101/R/35 > TELESCOPICO A UNO STADIO / ONE STAGE TELESCOPIC

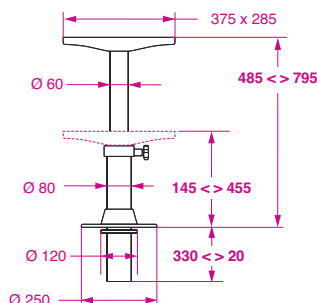

Il pistone può essere bloccato in ogni posizione intermedia. A manopola sbloccata può ruotare su 360°. In fase di montaggio la base può scorrere lungo il tubo inferiore per variare l'altezza minima. Spinta 30 Kg - Corsa 340 mm.

The piston can be locked in any intermediate position. When the handle is loose the top can rotate over 360°. The position of the bottom base can be adjusted along the lower tube to get the appropriate height. Push of 30 Kg - Stroke of 340 mm.

10101/R/35

Peso / Weight 6,1 Kg

cod. 08.10.31200

## 10101/R/40 > TELESCOPICO A UNO STADIO / ONE STAGE TELESCOPIC

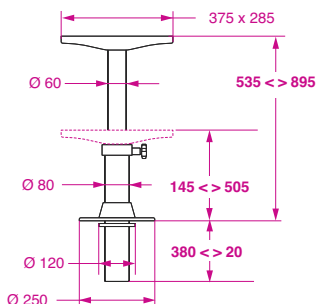

Il pistone può essere bloccato in ogni posizione intermedia. A manopola sbloccata può ruotare su 360°. In fase di montaggio la base può scorrere lungo il tubo inferiore per variare l'altezza minima. Spinta 30 Kg - Corsa 390 mm.

The piston can be locked in any intermediate position. When the handle is loose the top can rotate over 360°. The position of the bottom base can be adjusted along the lower tube to get the appropriate height. Push of 30 Kg - Stroke of 390 mm.

10101/R/40

Peso / Weight 6,5 Kg

cod. 08.10.31300

Tutte le misure sono espresse in mm / All measurements are in millimeters

## SUPPORTI TAVOLO A GAS / GAS POWERED TABLE PEDESTALS

### 12197/R > TELESCOPICO > CON SPORGENZA / TELESCOPIC > THROUGH FLOOR

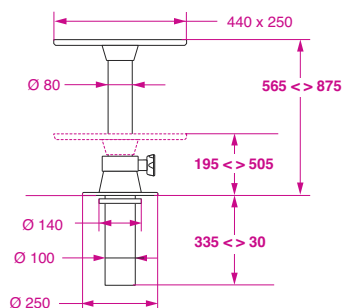

Il pistone può essere bloccato in ogni posizione intermedia. A manopola sbloccata può ruotare su 360°. In fase di montaggio la base può scorrere lungo il tubo inferiore per variare l'altezza minima. Spinta 30 Kg - Corsa 370 mm.

The piston can be locked in any intermediate position. When the handle is loose the top can rotate over 360°. The position of the bottom base can be adjusted along the lower tube to get the appropriate height. Push of 30 Kg - Stroke of 370 mm.

12197/R

Peso / Weight 9,6 Kg

cod. 08.10.01100

### 12197/A > TELESCOPICO > MOBILI / TELESCOPIC > MOVABLE

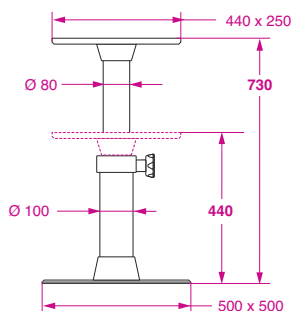

Spinta 30 Kg - Corsa 290 mm. Il pistone può essere bloccato in ogni posizione intermedia. A manopola sbloccata può ruotare su 360°.

Push of 30 Kg - Stroke of 290 mm. The piston can be locked in any intermediate position. When the handle is loose the top can rotate over 360°.

12197/A

Peso / Weight 14,7 Kg

cod. 08.10.02100

### 10101/A/30 > TELESCOPICO > MOBILI / TELESCOPIC > MOVABLE

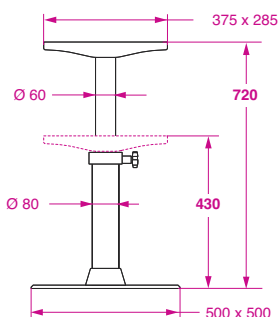

Spinta 30 Kg - Corsa 290 mm. Il pistone può essere bloccato in ogni posizione intermedia. A manopola sbloccata può ruotare su 360°.

Push of 30 Kg - Stroke of 290 mm. The piston can be locked in any intermediate position. When the handle is loose the top can rotate over 360°.

10101/A/30

Peso / Weight 11,5 Kg

cod. 08.10.32100

### 10101/A/35 > TELESCOPICO > MOBILI / TELESCOPIC > MOVABLE

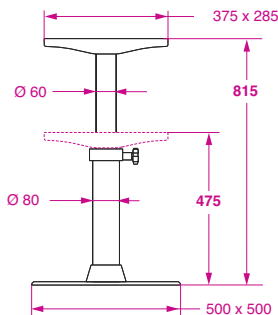

Spinta 30 Kg - Corsa 340 mm. Il pistone può essere bloccato in ogni posizione intermedia. A manopola sbloccata può ruotare su 360°.

Push of 30 Kg - Stroke of 340 mm. The piston can be locked in any intermediate position. When the handle is loose the top can rotate over 360°.

10101/A/35

Peso / Weight 11,6 Kg

cod. 08.10.32200

Tutte le misure sono espresse in mm / All measurements are in millimeters

## SUPPORTI TAVOLO MANUALI / MANUAL TABLE PEDESTALS

## 10199/M/30 &gt; TELESCOPICO A UNO STADIO / ONE STAGES TELESCOPIC

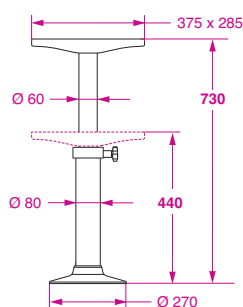

Corsa 290 mm.  
Il pistone può essere bloccato in ogni posizione intermedia.  
A manopola sbloccata può ruotare su 360°.

Stroke of 290 mm.  
The piston can be locked in any intermediate position.  
When the handle is loose the top can rotate over 360°.

10199/M/30

Peso / Weight 5 Kg

cod. 08.16.33101

## 10199/M/35 &gt; TELESCOPICO A UNO STADIO / ONE STAGES TELESCOPIC

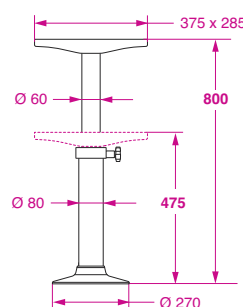

Corsa 325 mm.  
Il pistone può essere bloccato in ogni posizione intermedia.  
A manopola sbloccata può ruotare su 360°.

Stroke of 325 mm.  
The piston can be locked in any intermediate position.  
When the handle is loose the top can rotate over 360°.

10199/M/35

Peso / Weight 5,3 Kg

cod. 08.16.33201

## 10512 &gt; TELESCOPICO &gt; CON SPORGENZA / TELESCOPIC &gt; THROUGH FLOOR



GAMBA E BASE SUPERIORE POSSONO ESSERE SEPARATE  
THE PISTON AND UPPER BASE CAN BE SEPARATED

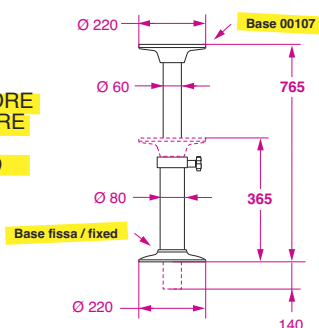

Corsa 400 mm.  
Il pistone può essere bloccato in ogni posizione intermedia.  
A manopola sbloccata può ruotare su 360°.  
Base optional 00102.

Stroke of 400 mm.  
The piston can be locked in any intermediate position.  
When the handle is loose the top can rotate over 360°.  
Optional base 00102.

10512

Peso / Weight 3,3 Kg

cod. 08.21.00001

## 10295 &gt; TELESCOPICO &gt; CON SPORGENZA / TELESCOPIC &gt; THROUGH FLOOR

supporto scomponibile / removable pedestal

GAMBA E BASI POSSONO ESSERE SEPARATE  
THE PISTON AND THE BASES CAN BE SEPARATED

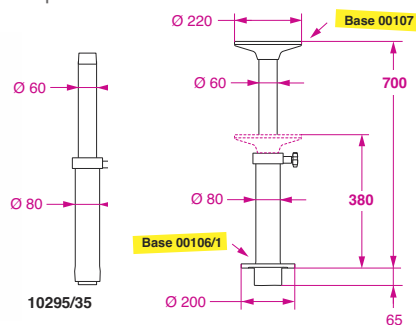

Corsa 320 mm.  
Amovibile, con base ad incasso.  
Basi optional 00102 - 00106.

Stroke of 320 mm.  
Removable, with flush deck base.  
Optional bases 00102 - 00106.

10295

Con basi / With bases

Peso / Weight 3,35 Kg

cod. 08.25.30001

10295/35

Senza basi / Without bases

Peso / Weight 1,9 Kg

cod. 08.25.33500

Tutte le misure sono espresse in mm / All measurements are in millimeters

GAMBA E BASI  
POSSONO ESSERE  
SEPARATE  
THE PISTON AND  
THE BASES  
CAN BE  
SEPARATED



ALTEZZA FISSA  
FIXED HEIGHT

## SUPPORTI TAVOLO SCOMPONIBILI / REMOVABLE TABLE PEDESTALS

10393

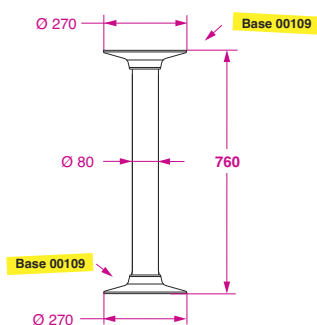

Basi / Bases optional 00106 - 00106/1.

10393

Peso / Weight 4,05 Kg

cod. 08.25.10003

10293

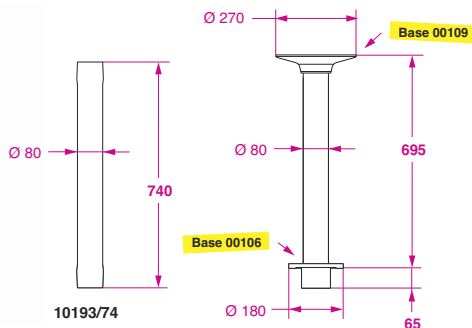

Supporto tavolo amovibile con base ad incasso.  
Basi optional 00106/1.

Removable table pedestal with flush deck base.  
Optional bases 00106/1.

10293

Con basi / With bases

Peso / Weight 3,25 Kg

cod. 08.25.10002

10193/74

Senza basi / Without bases

Peso / Weight 1,52 Kg

cod. 08.25.17400

10191

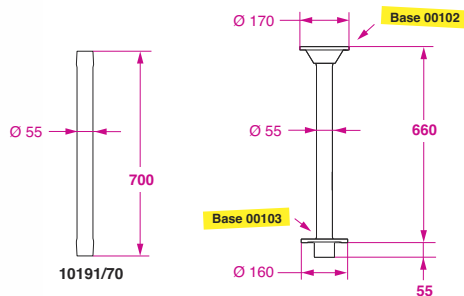

Supporto tavolo amovibile con base ad incasso.  
Basi optional 00107.

Removable table pedestal with flush deck base.  
Optional bases 00107.

10191

Con basi / With bases

Peso / Weight 1,50 Kg

cod. 08.25.00001

10191/70

Senza basi / Without bases

Peso / Weight 665 g

cod. 08.25.07000

Tutte le misure sono espresse in mm / All measurements are in millimeters

## SUPPORTI POLTRONA ELETTRICI / ELECTRIC CHAIR PEDESTALS

## 18131 &gt; TELESCOPICO A UNO STADIO / ONE STAGE TELESCOPIC

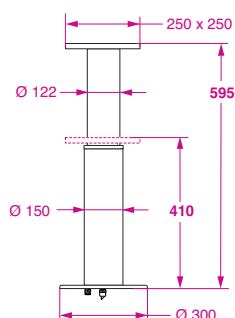

Spinta 250 Kg - Velocità 16 mm/sec - Corsa 185 mm.  
Centralina elettronica di controllo inclusa.

Push 250 Kg - Speed 16 mm/sec - Stroke 185 mm.  
Electronic control box included.

18131/12

12 Volt - 10 A

cod. 08.32.11012

18131/24

24 Volt - 5 A

Peso / Weight 11 Kg

cod. 08.32.11024

## 18P97 &gt; TELESCOPICO A UNO STADIO / ONE STAGE TELESCOPIC

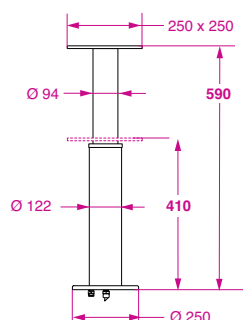

Spinta 250 Kg - Velocità 16 mm/sec - Corsa 180 mm.  
Centralina elettronica di controllo inclusa.

Push 250 Kg - Speed 16 mm/sec - Stroke 180 mm.  
Electronic control box included.

18P97/12

12 Volt - 10 A

cod. 08.32.15012

18P97/24

24 Volt - 5 A

cod. 08.32.15024

## 18141 &gt; TELESCOPICO A UNO STADIO / ONE STAGE TELESCOPIC

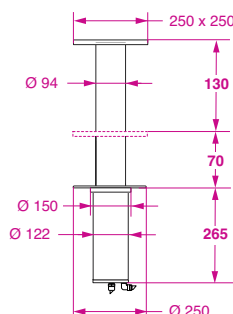

**Con sporgenza sotto pavimento.**  
Spinta 250 Kg - Velocità 16 mm/sec - Corsa 130 mm.  
Centralina elettronica di controllo inclusa.

**With underfloor protrusion.**  
Push 250 Kg - Speed 16 mm/sec - Stroke 130 mm.  
Electronic control box included.

18141/12

12 Volt - 10 A

cod. 08.32.13012

18141/24

24 Volt - 5 A

Peso / Weight 8,6 Kg

cod. 08.32.13024

## 13100 &gt; TELESCOPICO A UNO STADIO / ONE STAGE TELESCOPIC

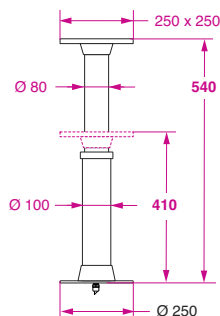

Spinta 250 Kg - Velocità 16 mm/sec - Corsa 130 mm.  
Centralina elettronica di controllo inclusa.

Push 250 Kg - Speed 16 mm/sec - Stroke 130 mm.  
Electronic control box included.

13100/12

12 Volt - 10 A

cod. 08.32.10012

13100/24

24 Volt - 5 A

Peso / Weight 8,9 Kg

cod. 08.32.10024

Tutte le misure sono espresse in mm / All measurements are in millimeters

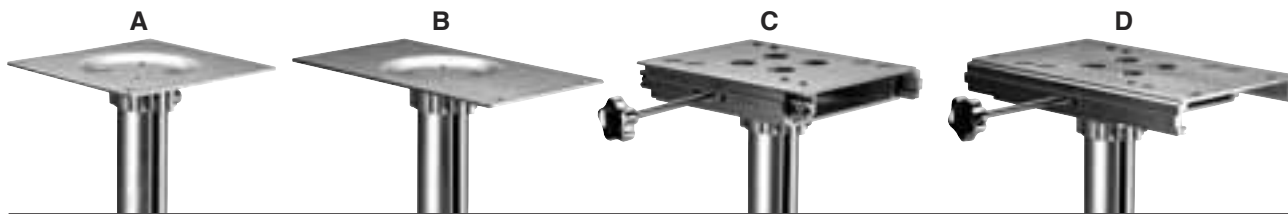

## SUPPORTI POLTRONA MANUALI / MANUAL CHAIR PEDESTALS

10800 > TELESCOPICO > MONOCOMANDO / TELESCOPIC > ONE HANDLE

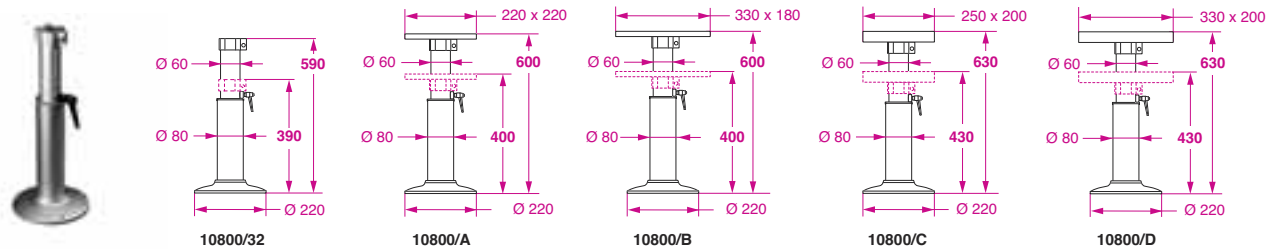

<b>10800/32</b>	senza piastra né slitta / without plate or slide	Peso / Weight 2,25 Kg	<b>cod. 08.40.10320</b>
<b>10800/A</b>	con piastra universale / with universal plate	2,885 Kg	<b>cod. 08.40.10001</b>
<b>10800/B</b>	con piastra adatta alle nostre poltrone / with plate suitable for our chairs	2,910 Kg	<b>cod. 08.40.10002</b>
<b>10800/C</b>	con slitta universale / with universal slide	4,050 Kg	<b>cod. 08.40.10003</b>
<b>10800/D</b>	con slitta adatta alle nostre poltrone / with slide suitable for our chairs	4,370 Kg	<b>cod. 08.40.10004</b>

10895 > TELESCOPICO > MONOCOMANDO / TELESCOPIC > ONE HANDLE

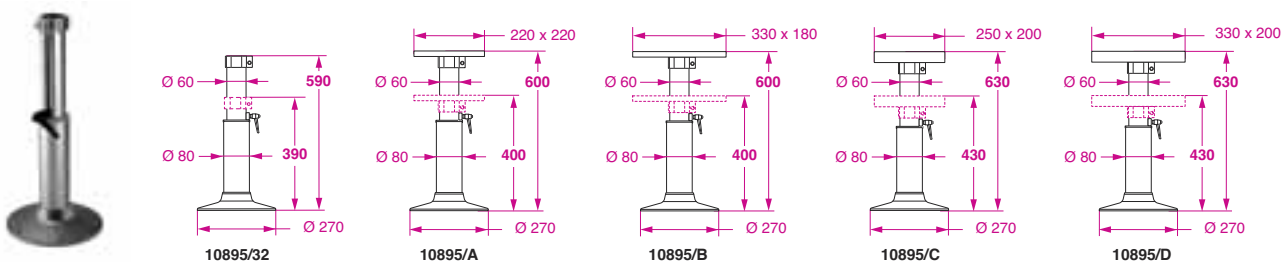

<b>10895/32</b>	senza piastra né slitta / without plate or slide	Peso / Weight 3 Kg	<b>cod. 08.40.13320</b>
<b>10895/A</b>	con piastra universale / with universal plate	3,635 Kg	<b>cod. 08.40.13001</b>
<b>10895/B</b>	con piastra adatta alle nostre poltrone / with plate suitable for our chairs	3,660 Kg	<b>cod. 08.40.13002</b>
<b>10895/C</b>	con slitta universale / with universal slide	4,18 Kg	<b>cod. 08.40.13003</b>
<b>10895/D</b>	con slitta adatta alle nostre poltrone / with slide suitable for our chairs	5,12 Kg	<b>cod. 08.40.13004</b>

10700 > TELESCOPICO > MONOCOMANDO / TELESCOPIC > ONE HANDLE

supporto scomponibile con base a incasso / removable pedestal with inset lower base (00106)

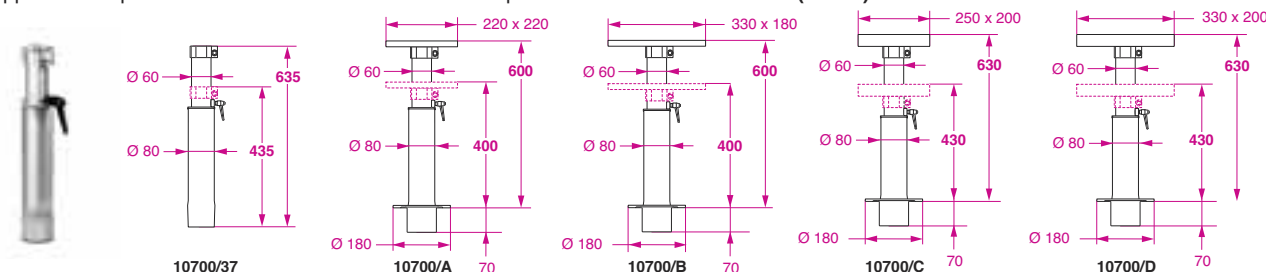

<b>10700/37</b>	senza base, piastra né slitta / without base, plate or slide	Peso / Weight 3 Kg	<b>cod. 08.40.12370</b>
<b>10700/A</b>	con piastra universale / with universal plate	2,855 Kg	<b>cod. 08.40.12001</b>
<b>10700/B</b>	con piastra adatta alle nostre poltrone / with plate suitable for our chairs	2,880 Kg	<b>cod. 08.40.12002</b>
<b>10700/C</b>	con slitta universale / with universal slide	4,020 Kg	<b>cod. 08.40.12003</b>
<b>10700/D</b>	con slitta adatta alle nostre poltrone / with slide suitable for our chairs	4,320 Kg	<b>cod. 08.40.12004</b>

Tutte le misure sono espresse in mm / All measurements are in millimeters





## SUPPORTI POLTRONA MANUALI / MANUAL CHAIR PEDESTALS

### 10600 > TELESCOPICO > DOPPIO COMANDO / TELESCOPIC > TWO HANDLES

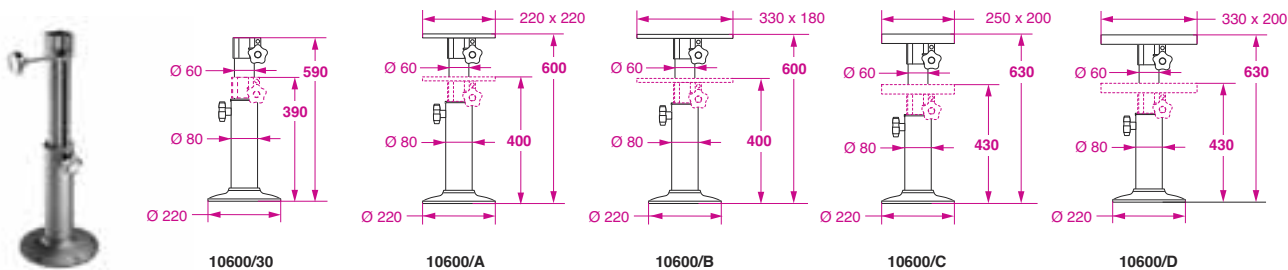

<b>10600/30</b>	senza piastra né slitta / without plate or slide	Peso / Weight 2,5 Kg	<b>cod. 08.40.00300</b>
<b>10600/A</b>	con piastra universale / with universal plate	3,135 Kg	<b>cod. 08.40.00001</b>
<b>10600/B</b>	con piastra adatta alle nostre poltrone / with plate suitable for our chairs	5,160 Kg	<b>cod. 08.40.00002</b>
<b>10600/C</b>	con slitta universale / with universal slide	4,3 Kg	<b>cod. 08.40.00003</b>
<b>10600/D</b>	con slitta adatta alle nostre poltrone / with slide suitable for our chairs	4,620 Kg	<b>cod. 08.40.00004</b>

### 10609 > TELESCOPICO > DOPPIO COMANDO / TELESCOPIC > TWO HANDLES

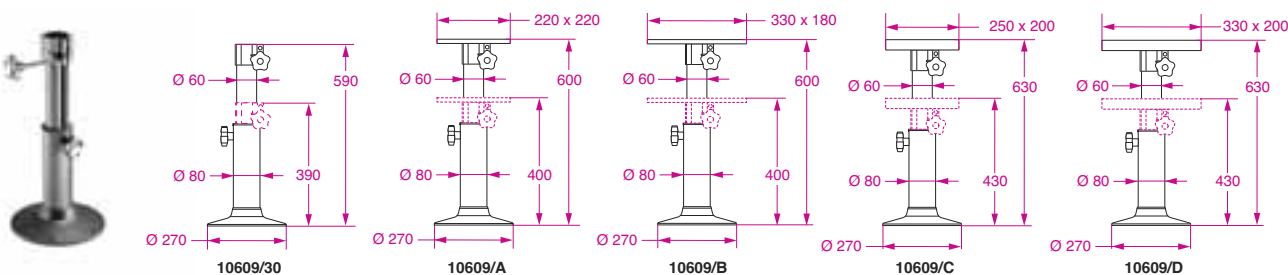

<b>10609/30</b>	senza piastra né slitta / without plate or slide	Peso / Weight 3,35 Kg	<b>cod. 08.40.02300</b>
<b>10609/A</b>	con piastra universale / with universal plate	3,985 Kg	<b>cod. 08.40.02001</b>
<b>10609/B</b>	con piastra adatta alle nostre poltrone / with plate suitable for our chairs	4,010 Kg	<b>cod. 08.40.02002</b>
<b>10609/C</b>	con slitta universale / with universal slide	5,150 Kg	<b>cod. 08.40.02003</b>
<b>10609/D</b>	con slitta adatta alle nostre poltrone / with slide suitable for our chairs	5,470 Kg	<b>cod. 08.40.02004</b>

### 10510 > TELESCOPICO > DOPPIO COMANDO / TELESCOPIC > TWO HANDLES

asportabile / through floor

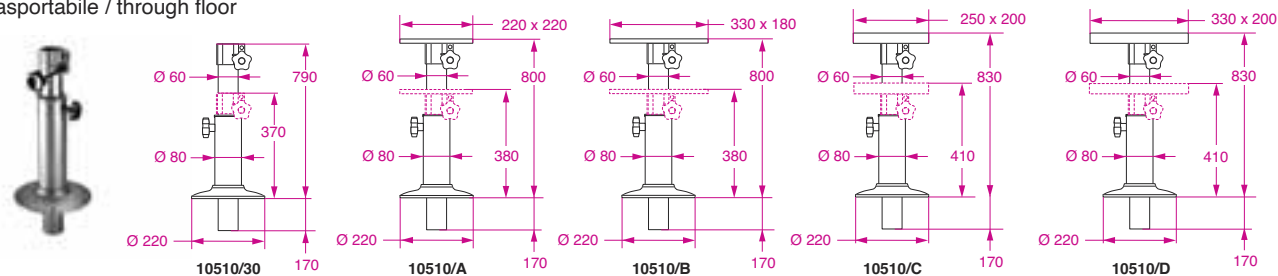

<b>10510/30</b>	senza piastra né slitta / without plate or slide	Peso / Weight 3,5 Kg	<b>cod. 08.40.20300</b>
<b>10510/A</b>	con piastra universale / with universal plate	4,135 Kg	<b>cod. 08.40.20001</b>
<b>10510/B</b>	con piastra adatta alle nostre poltrone / with plate suitable for our chairs	4,160 Kg	<b>cod. 08.40.20002</b>
<b>10510/C</b>	con slitta universale / with universal slide	5,3 Kg	<b>cod. 08.40.20003</b>
<b>10510/D</b>	con slitta adatta alle nostre poltrone / with slide suitable for our chairs	5,62 Kg	<b>cod. 08.40.20004</b>

Tutte le misure sono espresse in mm / All measurements are in millimeters

## SUPPORTI POLTRONA A GAS / GAS POWERED CHAIR PEDESTALS

10906 > TELESCOPICO > MOLLEGGIATO / TELESCOPIC > SOFT RIDE

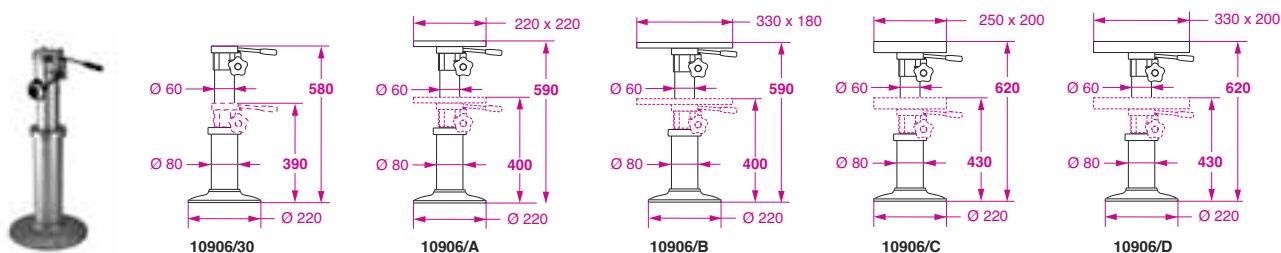

<b>10906/30</b>	senza piastra né slitta / without plate or slide	Peso / Weight 4,1 Kg	<b>cod. 08.30.01300</b>
<b>10906/A</b>	con piastra universale / with universal plate	4,735 Kg	<b>cod. 08.30.01001</b>
<b>10906/B</b>	con piastra adatta alle nostre poltrone / with plate suitable for our chairs	4,760 Kg	<b>cod. 08.30.01002</b>
<b>10906/C</b>	con slitta universale / with universal slide	5,9 Kg	<b>cod. 08.30.01003</b>
<b>10906/D</b>	con slitta adatta alle nostre poltrone / with slide suitable for our chairs	6,220 Kg	<b>cod. 08.30.01004</b>

10909 > TELESCOPICO > MOLLEGGIATO / TELESCOPIC > SOFT RIDE

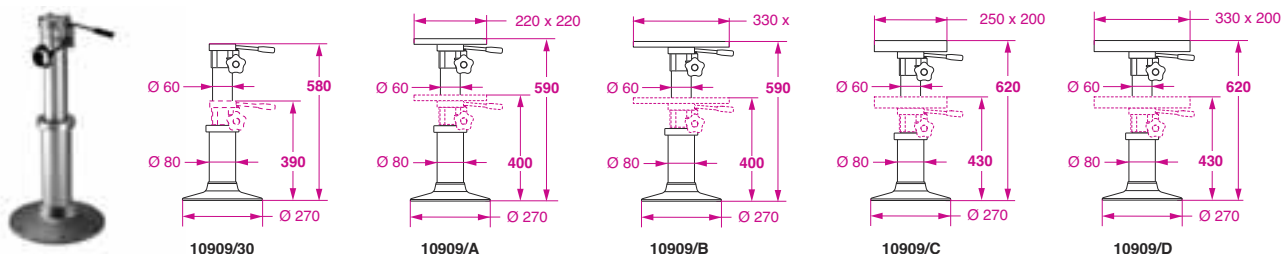

<b>10909/30</b>	senza piastra né slitta / without plate or slide	Peso / Weight 4,5 Kg	<b>cod. 08.30.02300</b>
<b>10909/A</b>	con piastra universale / with universal plate	5,135 Kg	<b>cod. 08.30.02001</b>
<b>10909/B</b>	con piastra adatta alle nostre poltrone / with plate suitable for our chairs	5,160 Kg	<b>cod. 08.30.02002</b>
<b>10909/C</b>	con slitta universale / with universal slide	6,3 Kg	<b>cod. 08.30.02003</b>
<b>10909/D</b>	con slitta adatta alle nostre poltrone / with slide suitable for our chairs	6,620 Kg	<b>cod. 08.30.02004</b>

ADATTI A POLTRONE PIÙ GRANDI E YACHT PIÙ VELOCI / SUITABLE FOR LARGER CHAIRS AND FASTER YACHTS

**12508**

TESTA GIREVOLE / SWIVEL TOP

**18608A**

TESTA GIREVOLE / SWIVEL TOP

**12508/R**

CON SPORGENZA E TESTA GIREVOLE / ADJUSTABLE LOWER BASE AND SWIVEL TOP

Il pistone può essere bloccato in ogni posizione intermedia.  
A manopola sbloccata può ruotare su 360°.

The piston can be locked in any intermediate position.  
When the handle is loose the top can rotate over 360°.

In fase di montaggio la base può scorrere lungo il tubo inferiore per variare l'altezza minima.  
The position of the bottom base can be adjusted along the lower tube to get the appropriate height.

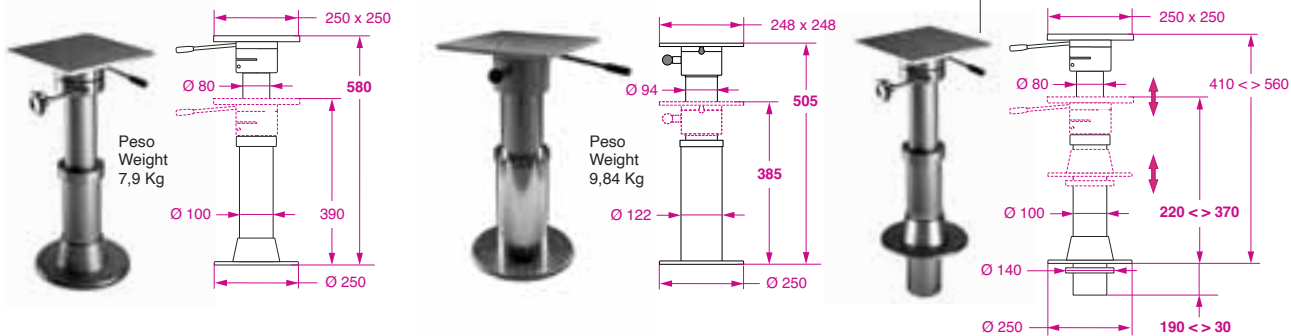

<b>12508</b>	<b>cod. 08.30.12000</b>	<b>18608A</b>	<b>cod. 08.30.14000</b>	<b>12508/R</b>	<b>cod. 08.30.13000</b>
--------------	-------------------------	---------------	-------------------------	----------------	-------------------------

Tutte le misure sono espresse in mm / All measurements are in millimeters



## SUPPORTI POLTRONA ALTEZZA FISSA / FIXED HEIGHT CHAIR PEDESTALS

### 10506 > GIREVOLE / SWIVEL TOP

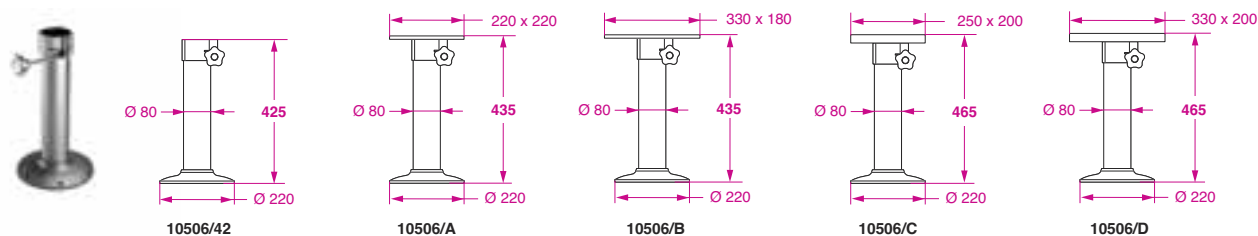

<b>10506/42</b>	senza piastra né slitta / without plate or slide	Peso / Weight 2,2 Kg	<b>cod. 08.35.10420</b>
<b>10506/A</b>	con piastra universale / with universal plate	2,835 Kg	<b>cod. 08.35.10001</b>
<b>10506/B</b>	con piastra adatta alle nostre poltrone / with plate suitable for our chairs	2,860 Kg	<b>cod. 08.35.10002</b>
<b>10506/C</b>	con slitta universale / with universal slide	4 Kg	<b>cod. 08.35.10003</b>
<b>10506/D</b>	con slitta adatta alle nostre poltrone / with slide suitable for our chairs	4,4 Kg	<b>cod. 08.35.10004</b>

### 10809 > GIREVOLE / SWIVEL TOP

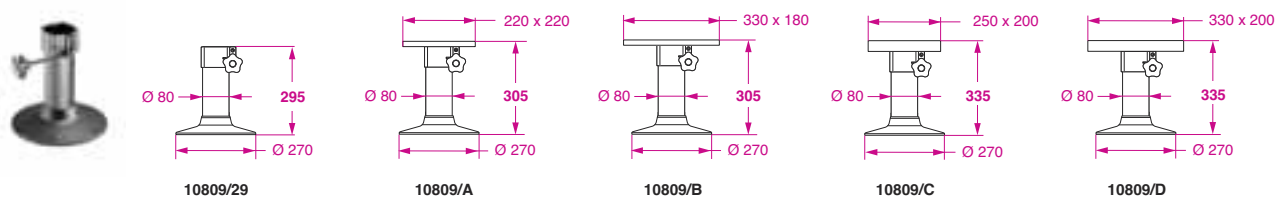

<b>10809/29</b>	senza piastra né slitta / without plate or slide	Peso / Weight 2,56 Kg	<b>cod. 08.35.12290</b>
<b>10809/A</b>	con piastra universale / with universal plate	3,195 Kg	<b>cod. 08.35.12001</b>
<b>10809/B</b>	con piastra adatta alle nostre poltrone / with plate suitable for our chairs	3,22 Kg	<b>cod. 08.35.12002</b>
<b>10809/C</b>	con slitta universale / with universal slide	4,36 Kg	<b>cod. 08.35.12003</b>
<b>10809/D</b>	con slitta adatta alle nostre poltrone / with slide suitable for our chairs	4,68 Kg	<b>cod. 08.35.12004</b>

### 10504 > GIREVOLE / SWIVEL TOP

supporto scomponibile con base a incasso / removable pedestal from inset lower base (00106)

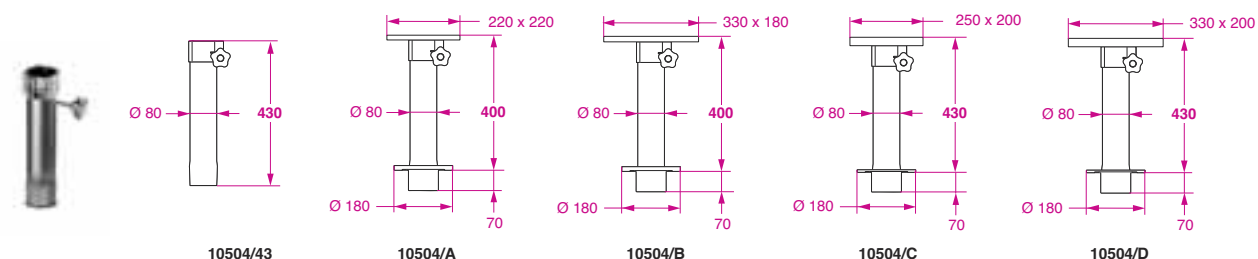

<b>10504/43</b>	senza base, piastra né slitta / without base, plate or slide	Peso / Weight 1,3 Kg	<b>cod. 08.35.32430</b>
<b>10504/A</b>	con piastra universale / with universal plate	4,055 Kg	<b>cod. 08.35.32001</b>
<b>10504/B</b>	con piastra adatta alle nostre poltrone / with plate suitable for our chairs	4,08 Kg	<b>cod. 08.35.32002</b>
<b>10504/C</b>	con slitta universale / with universal slide	5,22 Kg	<b>cod. 08.35.32003</b>
<b>10504/D</b>	con slitta adatta alle nostre poltrone / with slide suitable for our chairs	5,54 Kg	<b>cod. 08.35.32004</b>

Tutte le misure sono espresse in mm / All measurements are in millimeters

## POLTRONE / CHAIRS

### 11000 > YACHTSMAN

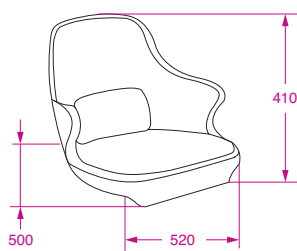

11000

Peso / Weight 3,1 Kg

Colore bianco.  
Materiale additivato  
con protettivo anti UV.

White color.  
Material improved  
with an anti UV additive.

cod. 07.01.00000

11010 coppia di cuscini / pair of cushions

cod. 07.11.00000

### 11001 > COMMODORE

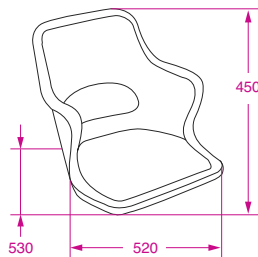

11001

Peso / Weight 3,5 Kg

Colore bianco.  
Materiale additivato  
con protettivo anti UV.

White color.  
Material improved  
with an anti UV additive.

cod. 07.01.10000

11010/1 coppia di cuscini / pair of cushions

cod. 07.11.00001

### 11002 > SEAFARER

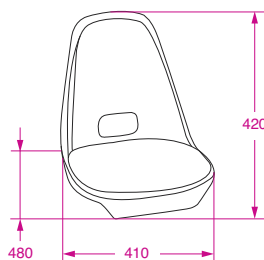

11002

Peso / Weight 2,8 Kg

Colore bianco.  
Materiale additivato  
con protettivo anti UV.

White color.  
Material improved  
with an anti UV additive.

cod. 07.01.20000

11010/2 coppia di cuscini / pair of cushions

cod. 07.11.00002

### 11004 > ADMIRAL

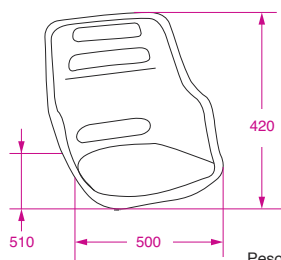

11004

Peso / Weight 3,3 Kg

Colore bianco.  
Materiale additivato  
con protettivo anti UV.

White color.  
Material improved  
with an anti UV additive.

cod. 07.01.40000

11010/4 coppia di cuscini / pair of cushions

cod. 07.11.00004

### 18801 > PROLUNGA SCORREVOLE PER TAVOLI A RIBALTA / SLIDE FOR FOLDING TABLES

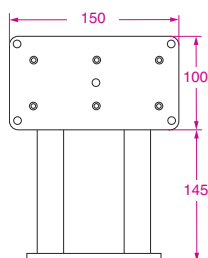

18801

Sostegno scorrevole  
in lega leggera anodizzata.  
Disponibile in diverse misure.

Sliding support  
in anodized light alloy.  
Available in different sizes.

cod. 08.92.00350

Tutte le misure sono espresse in mm / All measurements are in millimeters

## PIASTRE E SLITTE / PLATES AND SLIDES

## 00100 &gt; PIASTRA UNIVERSALE DI FISSAGGIO / UNIVERSAL TOP PLATE FOR CHAIR PEDESTALS

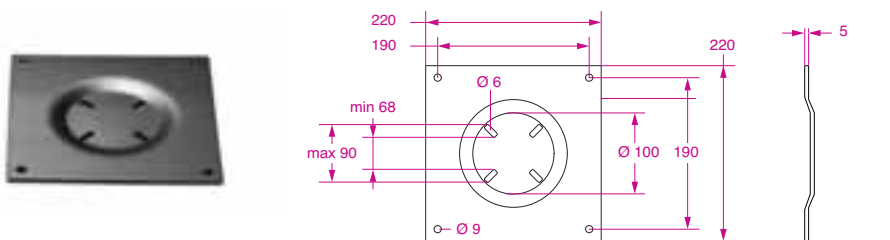

Costruita in lega leggera anodizzata.  
Anodized light alloy slide.

00100

Peso / Weight 635 g

cod. 08.92.00000

## 00101 &gt; PIASTRA PER LE NOSTRE POLTRONE / TOP PLATE SUITABLE FOR OUR CHAIRS

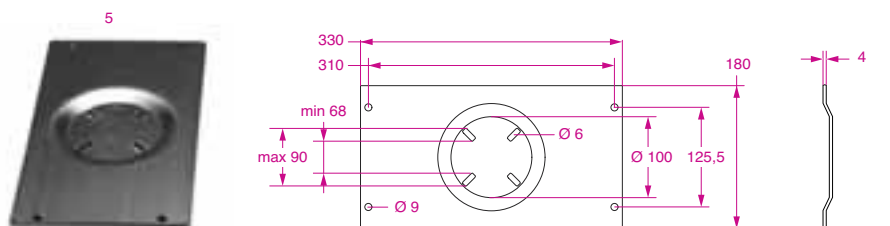

Costruita in lega leggera anodizzata.  
Anodized light alloy slide.

00101

Peso / Weight 660 g

cod. 08.92.00100

## 10900 &gt; SLITTA UNIVERSALE PER POLTRONE / UNIVERSAL SLIDE FOR CHAIR PEDESTALS

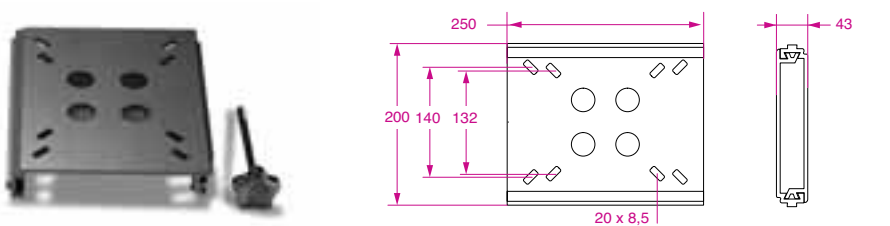

Costruita in lega leggera anodizzata.  
Corsa 190 mm.  
Anodized light alloy slide.  
Stroke 190 mm.

10900

Peso / Weight 1,8 Kg

cod. 08.92.00200

## 10901 &gt; SLITTA PER LE NOSTRE POLTRONE / SLIDE FOR OUR CHAIRS

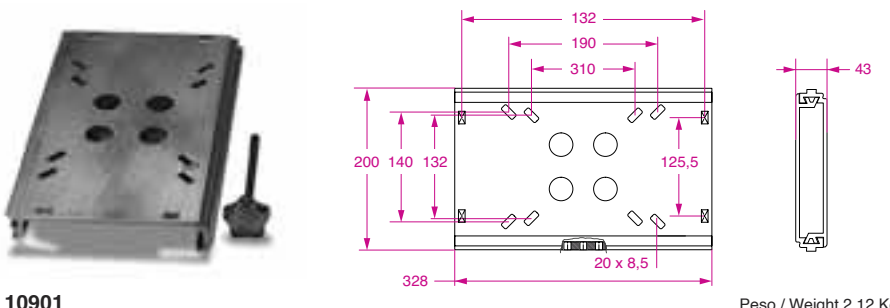

Costruita in lega leggera anodizzata.  
Corsa 135 mm.  
Anodized light alloy slide.  
Stroke 135 mm.

10901

Peso / Weight 2,12 Kg

cod. 08.92.00300

## 10903 &gt; SLITTA PER TAVOLI / SLIDE FOR TABLES

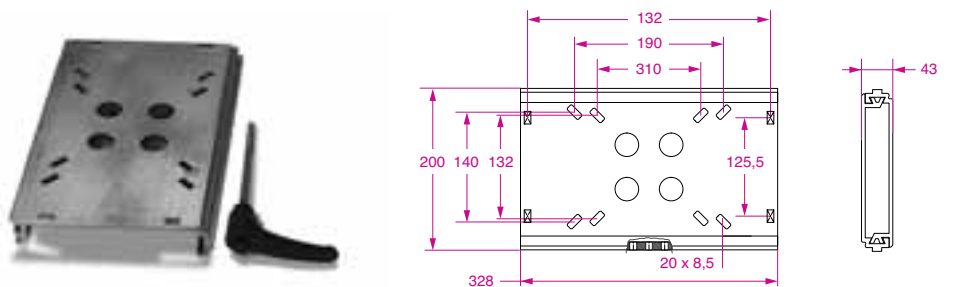

Costruita in lega leggera anodizzata.  
Corsa 270 mm.  
Anodized light alloy slide.  
Stroke 270 mm.

10903

Peso / Weight 2,35 Kg

cod. 08.92.00305

Tutte le misure sono espresse in mm / All measurements are in millimeters

## BASI / BASES

### 00102 > BASE PER SUPPORTI ASPORTABILI / BASE FOR REMOVABLE PEDESTALS

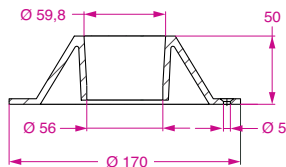

Costruita in alluminio sabbato, anodizzato e brillantato.

Made in sand blast, anodized and shined light alloy.

00102

Peso / Weight 330 g

cod. 08.90.00102

### 00103 > BASE INFERIORE AD INCASSO PER SUPPORTI ASPORTABILI EMBEDDED BOTTOM BASE FOR REMOVABLE PEDESTALS

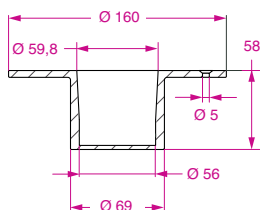

Costruita in alluminio lucidato e anodizzato.

Made in polished and anodized light alloy.

00103

Peso / Weight 410 g

cod. 08.90.00103

### 00106 > BASE INFERIORE AD INCASSO PER SUPPORTI ASPORTABILI EMBEDDED BOTTOM BASE FOR REMOVABLE PEDESTALS

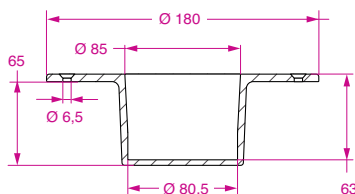

Costruita in alluminio sabbato, anodizzato e brillantato.

Made in sand blast, anodized and shined light alloy.

00106

Peso / Weight 475 g

cod. 08.90.00106

### 00106/1 > BASE INFERIORE AD INCASSO PER SUPPORTI ASPORTABILI EMBEDDED BOTTOM BASE FOR REMOVABLE PEDESTALS

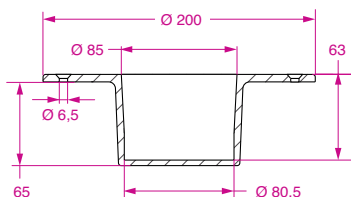

Costruita in alluminio lucidato e anodizzato.

Made in polished and anodized light alloy.

00106/1

Peso / Weight 590 g

cod. 08.90.00116

### 00107 > BASE PER SUPPORTI ASPORTABILI / EMBEDDED BASE FOR REMOVABLE PEDESTALS

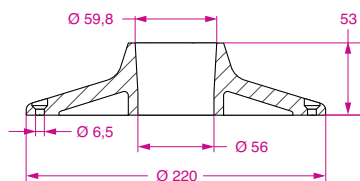

Costruita in alluminio sabbato, anodizzato e brillantato.

Made in sand blast, anodized and shined light alloy.

00107

Peso / Weight 725 g

cod. 08.90.00107

Tutte le misure sono espresse in mm / All measurements are in millimeters

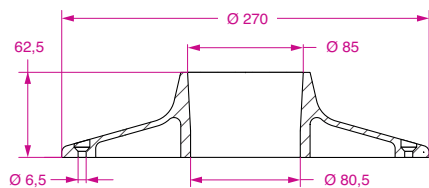

**00109 > BASE PER SUPPORTI ASPORTABILI / BASE FOR REMOVABLE PEDESTALS**

Costruita in alluminio sabbato,  
anodizzato e brillantato.

Made in sand blast,  
anodized and shined light alloy .

**00109**

Peso / Weight 1,26 Kg

**cod. 08.90.00109****00222 > COPRIFORO PER BASE AD INCASSO / COVER FOR INSET BASE**

Copriforo in plastica .  
Per base **00103**.  
Utilizzata nel supporto **10191**.

Plastic lid.  
For **00103** base.  
Used with the **10191** pedestal.

**00222****cod. 08.90.00222****00292 > COPRIFORO PER BASE AD INCASSO / COVER FOR INSET BASE**

Copriforo in plastica.  
Per basi **00106** e **00106/1**.  
Utilizzato nei supporti:  
**10193 - 10293**  
**10295 - 10504 - 10700**.

Plastic lid.  
For bases **00106** and **00106/1**.  
Used with the:  
**10193 - 10293 - 10295**  
**10504 - 10700** pedestals.

**00292**

Peso / Weight 83 g

**cod. 08.90.00292**

Regolazione base inferiore  
Setup lower base

Tutte le misure sono espresse in mm / All measurements are in millimeters

# ACCESSORI E RICAMBI / SPARE PARTS & ACCESSORIES

## 01053/XXX/XX > CENTRALINA ELETTRONICA / CONTROL BOX

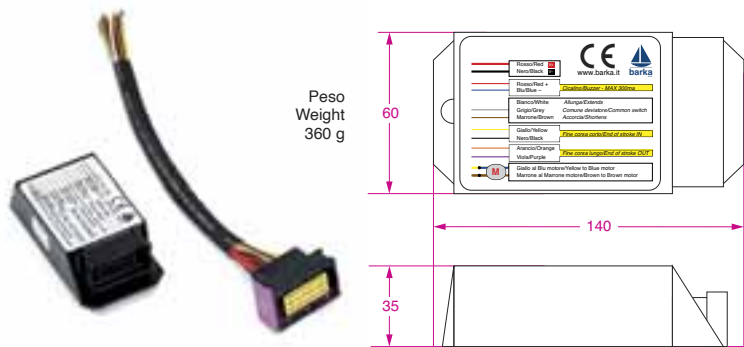

Per supporti elettrici senza encoder.  
Costruita in plastica,  
con circuiti immersi in resina ignifuga.  
**Indicare la TIPOLOGIA DEL SUPPORTO  
(poltrona o tavolo, uno o due stadi)  
e i relativi voltaggi.**

For electric pedestals without encoder.  
Built in plastic, with the  
electronics sealed in a self-extinguishing resin.  
**Indicate the SERIAL NUMBER  
of the item or the characteristic  
(chair or table, one or two stage)  
voltage and amperage.**

ARTICOLO / ITEM		VOLT	AMPERE	CODICE / CODE
01053/15A/12	per supporti tavolo, poltrona e attuatori  for table pedestals, chairs pedestals and struts	12	15	09.99.00017
01053/7,5A/24		24	7,5	09.99.00018
01053/12A/12		12	12	09.99.00015
01053/6A/24		24	6	09.99.00016
01053/10A/12		12	10	09.99.00011
01053/5A/24		24	5	09.99.00012
01053/8A/12		12	8	09.99.00013
01053/4A/24		24	4	09.99.00014
01053/100/12		12	7	09.99.00009
01053/100/24		24	3,5	09.99.00010
01053/150/12		12	6	09.99.00001
01053/150/24		24	3	09.99.00002
01053/200/12		12	8	09.99.00003
01053/200/24		24	4	09.99.00004

## E 02134/XX > CENTRALINA ELETTRONICA PER IMPIANTI CON ENCODER CONTROL BOX FOR SYNCHRONIZED UNITS WITH ENCODER

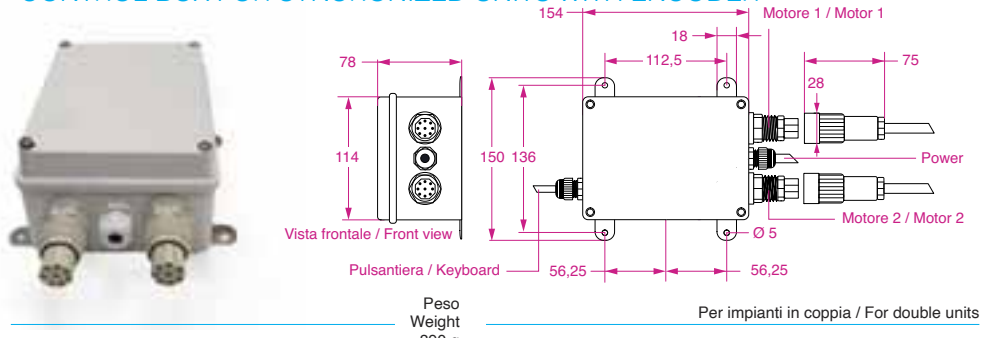

Per IMPIANTI  
CON ENCODER e  
sincronizzati.  
**Indicare la tipologia  
del supporto  
(singolo o coppia,  
poltrona o tavolo,  
uno o due stadi)  
e i relativi voltaggi.**

For synchronized  
UNITS WITH  
ENCODER.  
**Indicate the  
SERIAL NUMBER  
of the item or  
the characteristic  
(single or pair,  
chair or table,  
one or two stage)  
voltage and amperage.**

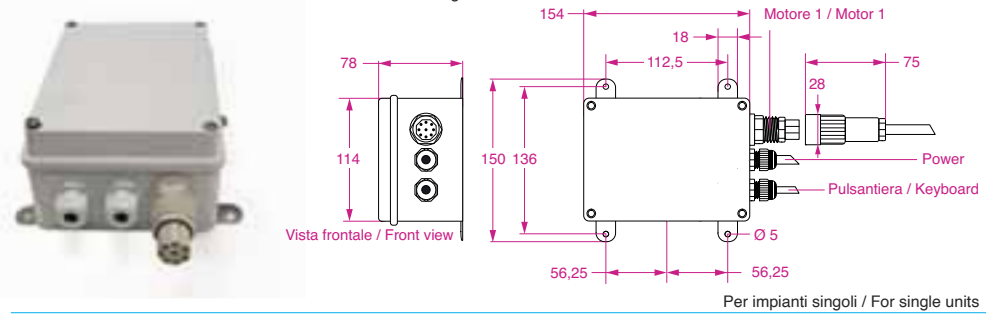

Tutte le misure sono espresse in mm / All measurements are in millimeters

**E01135 > TASTIERA / KEYBOARD**

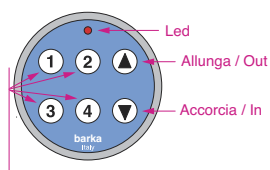

Tasti Posizionamento Automatico (da programmare)  
Keys for automatic positioning (to be set up)

Tastiera di regolazione e comando, per impianti con encoder. Costruzione in plastica, con circuiti immersi in resina idrofuga.

Set-up and operating keyboard, for units with encoder. Made in plastic, with circuits immersed in a waterproof resin.

**E01135**

Peso / Weight 90 g

**cod. 09.99.00056**

**E01160 > PASSAPARATIA STAGNO / THROUGH BULKHEAD GLAND**



Peso / Weight 31 g

Passa paratia opzionale, per i nostri cavi con connettore. Corpo in polipropilene nero.

Through bulkhead gland, for BARKA's cables with plug (optional). Black polypropylene body.

**E01160**

**cod. 09.99.00057**

**01167 > CAVO DI PROLUNGA / EXTENSION**



Cavi (opzionali) di prolunga, per impianti con encoder. Indispensabili quando la lunghezza dei cavi standard (1,30 m) non consente di raggiungere la centralina di controllo.

Extension (optional) cables, for units with encoder. Indispensables when the length of the standard cables (1,30 m) is insufficient to reach the control box.

**01167**

2 metri / meters

Peso / Weight 260 g

**cod. 09.99.00054**

**01168**

5 metri / meters

Peso / Weight 520 g

**cod. 09.99.00055**

**01180**

8 metri / meters

Peso / Weight 755 g

**cod. 09.99.00059**

**RTX2RC > TELECOMANDO / REMOTE CONTROL**



Kit telecomando con ricevitore. Consente di comandare da remoto il movimento degli attuatori e dei supporti tavolo.

Complete remote control unit. It allows to drive the movement of the struts and table pedestals from remote.

**RTX2RC**

kit telecomando + ricevitore / kit remote control + receiver

**cod. 09.99.00061**

**TX2RC**

telecomando aggiuntivo / additional remote control

**cod. 09.99.00062**

**BEBIP > AVVISATORE DI MOVIMENTO / MOVEMENT ALARM**

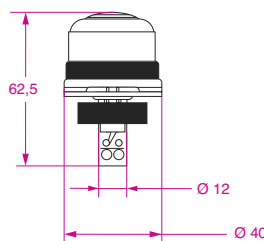

Avvisatore acustico di movimento. 12 o 24 Volt. Grado di protezione da polvere ed acqua: IP55.

Buzzer. 12 or 24 Volt. Degree of protection from dust and water: IP55.

**BEBIP/12**

**cod. 09.99.00051**

**BEBIP/24**

**cod. 09.99.00052**

Tutte le misure sono espresse in mm / All measurements are in millimeters

## W18000 > GUARNIZIONE TATTILE / SAFETY PRESSURE SENSOR

**Kit di sicurezza – Completo di elettronica (TX RX Wi-fi) e guarnizione tattile.**  
**Security kit – Complete of WiFi electronics (TX x RX) and pressure sensor.**

- Il bordo sensibile di sicurezza viene utilizzato per eliminare il rischio di schiacciamento dovuto a parti in movimento quali tavoli, porte scorrevoli, paratie mobili, ecc.
- The safety tactile seal is used to eliminate the risk of crushing due to moving parts such as tables, sliding doors, movable bulkheads, etc.

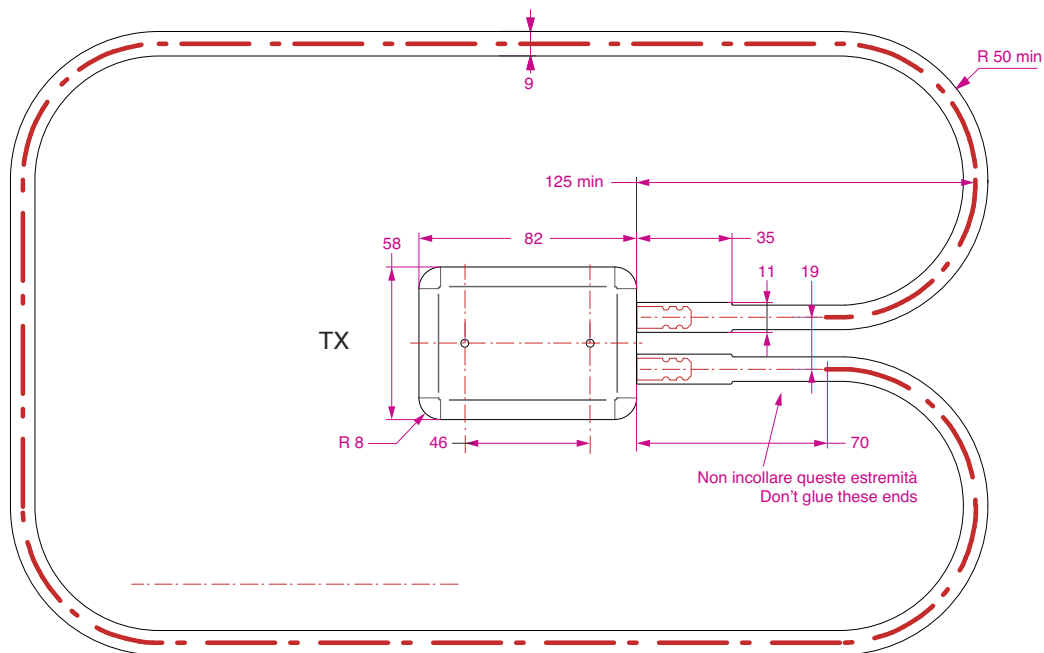
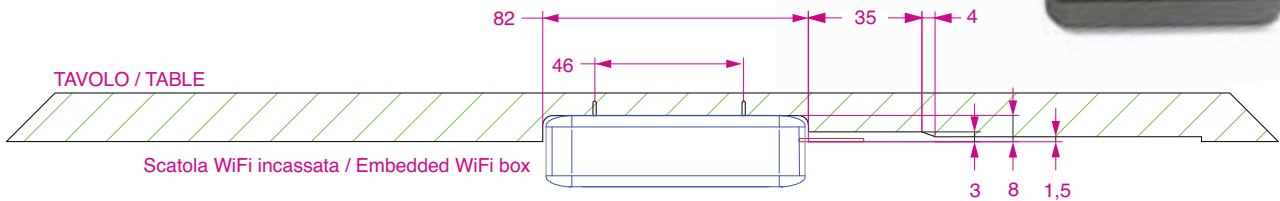

<b>W18000</b>	5 metri / meters	Peso/Weight 280 g	<b>cod. 09.99.00070</b>
<b>W18001</b>	8 metri / meters	Peso/Weight 483 g	<b>cod. 09.99.00071</b>
<b>W18002</b>	10 metri / meters	Peso/Weight 687 g	<b>cod.09.99.00072</b>

Tutte le misure sono espresse in mm / All measurements are in millimeters



# SPINTA / THRUST 1800 N (180 KG)

VELOCITÀ / SPEED > 18 mm/sec

Realizzabili con corse comprese fra 50 a 1500 mm / Available with strokes from 50 to 1500 mm

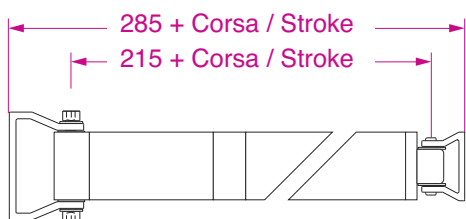

Lunghezza attuatore chiuso  
Length of the closed strut

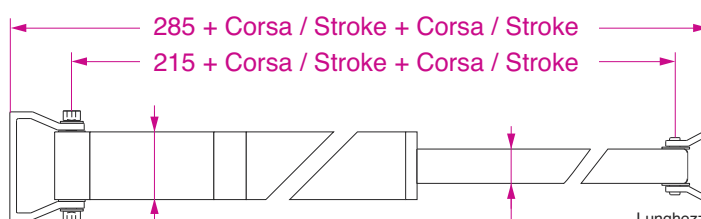

Lunghezza attuatore esteso  
Length of the extended strut

Amp.	Amp.								mm/sec
4	8								18
3,5	7								17,5
3	6								17
2,5	5								16
2	4								14
1,5	3								13
1,25	2,5								11
24 VDC	12 VDC	Kg 50	Kg 100	Kg 120	Kg 140	Kg 160	Kg 180	carico/load	

4 cicli 10 minuti di pausa  
4 cycles 10 minutes stop

2 cicli 10 minuti di pausa  
2 cycles 10 minutes stop

Velocità in mm/sec  
Speed mm/sec

Consumo in A.  
Current

Versioni SEMPLICE E DOPPIO EFFETTO / PUSH only & PUSH-PULL version  
Disponibile la versione per il montaggio in coppia. / Available as a pair.

Forniti con una centralina elettronica di controllo e protezione per ogni attuatore. / Supplied with an electronic control box for each strut to control.

Cavo di alimentazione da 1,30 m. / 1.30 m power cable.

A richiesta sensori di fine corsa regolabili. / On request adjustable magnetic end of stroke.

Per l'impiego occorre aggiungere un interruttore a 3 posizioni con ritorno automatico a zero. / It's necessary to add a 3 positions switch with automatic return to the OFF state.

Il cablaggio consente, se necessario, l'impiego di un avvisatore di movimento acustico/luminoso. An acoustic/flashing movement warning is available on request.

A richiesta versioni a 12 o 24 VCC. / Available for 12 or 24 VDC power.

Kit per comando da remoto opzionale / Remote control unit (optional)

Versioni con e senza ENCODER / With or without ENCODER version.

Disponibile a richiesta cavo di prolunga da 2-5-8 m. / Optional extension cable of 2 - 5 or 8 m.

Passa paratia opzionale per i nostri cavi con connettore. / Through bulkhead gland for BARKA's cables with plug (optional)

Articolo Item	Installazione Mounting	Effetto Push	Sincronizzazione Synchronization	Corsa Stroke	Volt	Peso Weight	Codice Code
3A250/12		semplice effetto / push only		250 mm	12	2,8 Kg	cod. 09.00.02501
3A250/24		semplice effetto / push only		250 mm	24	2,8 Kg	cod. 09.00.02502
3A250/C/12	coppia / pair	semplice effetto / push only		250 mm	12	5,5 Kg	cod. 09.02.02501
3A250/C/24	coppia / pair	semplice effetto / push only		250 mm	24	5,5 Kg	cod. 09.02.02502
3A480/12		semplice effetto / push only		480 mm	12	3 Kg	cod. 09.00.04801
3A480/24		semplice effetto / push only		480 mm	24	3 Kg	cod. 09.00.04802
3A480/C/12	coppia / pair	semplice effetto / push only		480 mm	12	6,4 Kg	cod. 09.02.04801
3A480/C/24	coppia / pair	semplice effetto / push only		480 mm	24	6,4 Kg	cod. 09.02.04802
3A580/12		semplice effetto / push only		580 mm	12	4 Kg	cod. 09.00.05801
3A580/24		semplice effetto / push only		580 mm	24	4 Kg	cod. 09.00.05802
3A580/C/12	coppia / pair	semplice effetto / push only		580 mm	12		cod. 09.02.05801
3A580/C/24	coppia / pair	semplice effetto / push only		580 mm	24		cod. 09.02.05802
4A480/12		doppio effetto / push-pull		480 mm	12	3,5 Kg	cod. 09.08.04801
4A480/24		doppio effetto / push-pull		480 mm	24	3,5 Kg	cod. 09.08.04802
4A480/C/12	coppia / pair	doppio effetto / push-pull		480 mm	12	7 Kg	cod. 09.10.04801
4A480/C/24	coppia / pair	doppio effetto / push-pull		480 mm	24	7 Kg	cod. 09.10.04802
4A580/12		doppio effetto / push-pull		580 mm	12	6 Kg	cod. 09.08.05801
4A580/24		doppio effetto / push-pull		580 mm	24	6 Kg	cod. 09.08.05802
4A580/C/12	coppia / pair	doppio effetto / push-pull		580 mm	12	7 Kg	cod. 09.10.05801
4A580/C/24	coppia / pair	doppio effetto / push-pull		580 mm	24	7 Kg	cod. 09.10.05802
ES4A480/2/12	coppia / pair	doppio effetto / push-pull	encoder	480 mm	12		cod. 09.14.04801
ES4A480/2/24	coppia / pair	doppio effetto / push-pull	encoder	480 mm	24		cod. 09.14.04802
ES4A580/2/12	coppia / pair	doppio effetto / push-pull	encoder	580 mm	12		cod. 09.14.05801
ES4A580/2/24	coppia / pair	doppio effetto / push-pull	encoder	580 mm	24		cod. 09.14.05802

Tutte le misure sono espresse in mm / All measurements are in millimeters



# SPINTA / THRUST 2500 N (250 KG)

**VELOCITÀ / SPEED > 19 mm/sec**

Realizzabili con corse comprese fra 50 a 1500 mm / Available with strokes from 50 to 1500 mm

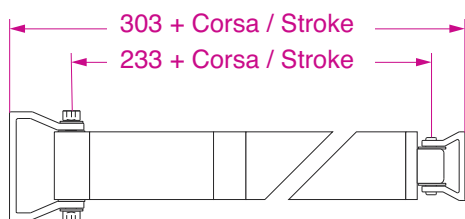

Lunghezza attuatore chiuso  
Length of the closed strut

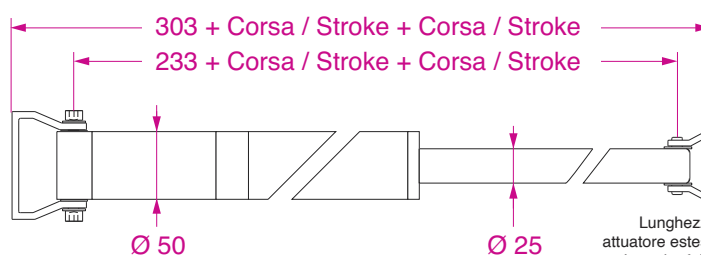

Lunghezza attuatore esteso  
Length of the extended strut

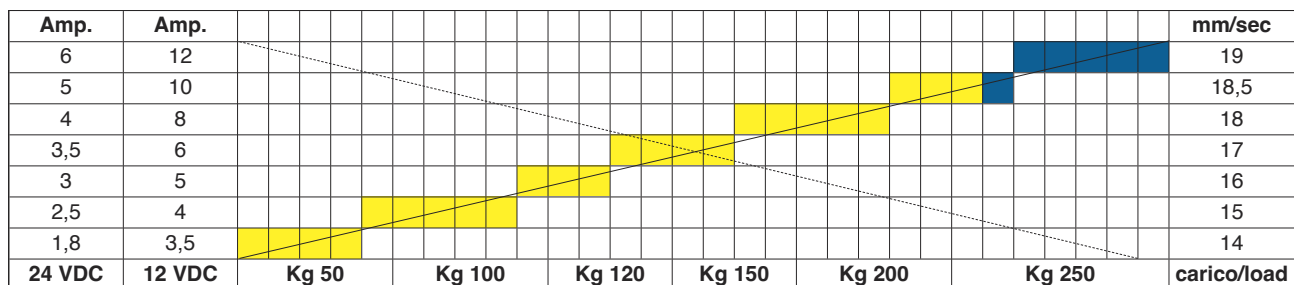

4 cicli 10 minuti di pausa  
4 cycles 10 minutes stop

2 cicli 10 minuti di pausa  
2 cycles 10 minutes stop

----- Velocità in mm/sec  
Speed mm/sec

----- Consumo in A.  
Current

Versioni **SEMPLICE E DOPPIO EFFETTO / PUSH only & PUSH-PULL** version

Disponibile la versione per il montaggio **in coppia**. / Available as a **pair**.

Forniti con una **centralina elettronica** di controllo e protezione per ogni attuatore. / Supplied with an **electronic control box** for each strut to control.

Cavo di alimentazione da 1,30 m. / 1.30 m power cable.

A richiesta **sensori di fine corsa** regolabili. / On request adjustable **magnetic end of stroke**.

Per l'impiego occorre aggiungere un interruttore a 3 posizioni con ritorno automatico a zero. / It's necessary to add a 3 positions switch with automatic return to the OFF state.

Il cablaggio consente, se necessario, l'impiego di un **avvisatore di movimento acustico/luminoso**. An **acoustic/flashing movement** warning is available on request.

A richiesta versioni a **12 o 24 VCC**. / Available for **12 or 24 VDC** power.

**Kit per comando da remoto** opzionale / **Remote control unit** (optional)

Versioni con e senza **ENCODER** / With or without **ENCODER** version.

Disponibile a richiesta cavo di **prolunga da 2-5-8 m**. / Optional **extension cable of 2 - 5 or 8 m**.

**Passa paratia** opzionale per i nostri cavi con connettore. / **Through bulkhead gland** for BARKA's cables with plug (optional)

Articolo Item	Installazione Mounting	Effetto Push	Sincronizzazione Synchronization	Corsa Stroke	Volt	Peso Weight	Codice Code
3B480/12		semplice effetto / push only		480 mm	12	3,2 Kg	cod. 09.32.04801
3B480/24		semplice effetto / push only		480 mm	24	3,2 Kg	cod. 09.32.04802
3B480/C/12	coppia / pair	semplice effetto / push only		480 mm	12		cod. 09.34.04801
3B480/C/24	coppia / pair	semplice effetto / push only		480 mm	24		cod. 09.34.04802
3B580/12		semplice effetto / push only		580 mm	12	3,48 Kg	cod. 09.32.05801
3B580/24		semplice effetto / push only		580 mm	24	3,48 Kg	cod. 09.32.05802
3B580/C/12	coppia / pair	semplice effetto / push only		580 mm	12	7,5 Kg	cod. 09.34.05801
3B580/C/24	coppia / pair	semplice effetto / push only		580 mm	24	7,5 Kg	cod. 09.34.05802
4B480/12		doppio effetto / push-pull		480 mm	12		cod. 09.40.04801
4B480/24		doppio effetto / push-pull		480 mm	24		cod. 09.40.04802
4B480/C/12	coppia / pair	doppio effetto / push-pull		480 mm	12		cod. 09.42.04801
4B480/C/24	coppia / pair	doppio effetto / push-pull		480 mm	24		cod. 09.42.04802
4B580/12		doppio effetto / push-pull		580 mm	12	3,5 Kg	cod. 09.40.05801
4B580/24		doppio effetto / push-pull		580 mm	24	3,5 Kg	cod. 09.40.05802
4B580/C/12	coppia / pair	doppio effetto / push-pull		580 mm	12	6 Kg	cod. 09.42.05801
4B580/C/24	coppia / pair	doppio effetto / push-pull		580 mm	24	6 Kg	cod. 09.42.05802
ES4B480/2/12	coppia / pair	doppio effetto / push-pull	encoder	480 mm	12	6 Kg	cod. 09.46.04801
ES4B480/2/24	coppia / pair	doppio effetto / push-pull	encoder	480 mm	24	6 Kg	cod. 09.46.04802
ES4B580/2/12	coppia / pair	doppio effetto / push-pull	encoder	580 mm	12	8 Kg	cod. 09.46.05801
ES4B580/2/24	coppia / pair	doppio effetto / push-pull	encoder	580 mm	24	8 Kg	cod. 09.46.05802

Tutte le misure sono espresse in mm / All measurements are in millimeters

# SPINTA / THRUST 3000 N (300 KG)

VELOCITÀ / SPEED > 9,5 mm/sec

Realizzabili con corse comprese fra 50 a 1500 mm / Available with strokes from 50 to 1500 mm

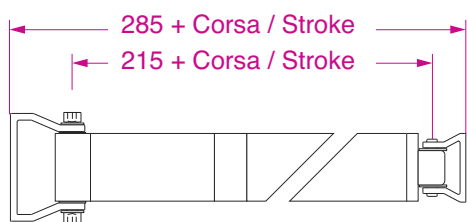

Lunghezza attuatore chiuso  
Length of the closed strut

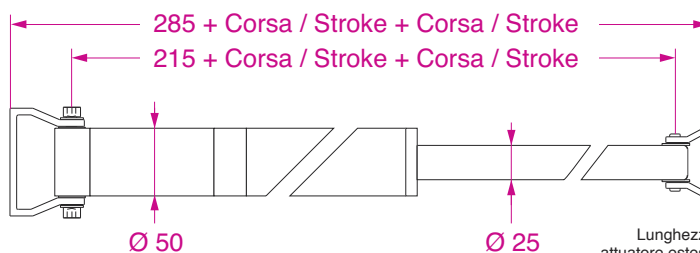

Lunghezza attuatore esteso  
Length of the extended strut

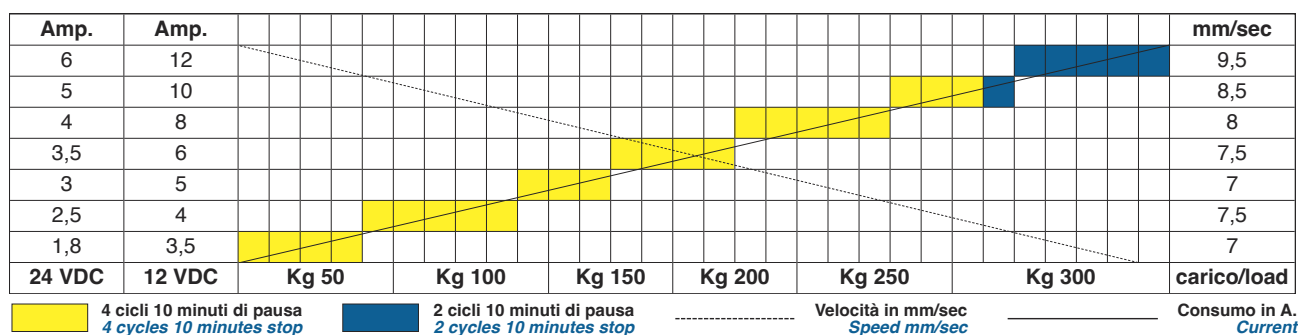

Articolo Item	Installazione Mounting	Effetto Push	Sincronizzazione Synchronization	Corsa Stroke	Volt	Peso Weight	Codice Code
3A480/P4/12		semplice effetto / push only		480 mm	12	3,2 Kg	cod. 09.16.04801
3A480/P4/24		semplice effetto / push only		480 mm	24	3,2 Kg	cod. 09.16.04802
3A580/P4/12		semplice effetto / push only		580 mm	12		cod. 09.16.05801
3A580/P4/24		semplice effetto / push only		580 mm	24		cod. 09.16.05802
4A480/P4/12		doppio effetto / push-pull		480 mm	12	3 Kg	cod. 09.24.04801
4A480/P4/24		doppio effetto / push-pull		480 mm	24	3 Kg	cod. 09.24.04802
4A580/P4/12		doppio effetto / push-pull		580 mm	12		cod. 09.24.05801
4A580/P4/24		doppio effetto / push-pull		580 mm	24		cod. 09.24.05802
ES4A480/P4/2/12	coppia / pair	doppio effetto / push-pull	encoder	480 mm	12		cod. 09.30.04801
ES4A480/P4/2/24	coppia / pair	doppio effetto / push-pull	encoder	480 mm	24		cod. 09.30.04802
ES4A580/P4/2/12	coppia / pair	doppio effetto / push-pull	encoder	580 mm	12		cod. 09.30.05801
ES4A580/P4/2/24	coppia / pair	doppio effetto / push-pull	encoder	580 mm	24		cod. 09.30.05802



Tutte le misure sono espresse in mm / All measurements are in millimeters

# SPINTA / THRUST 3500 N (350 KG)

**VELOCITÀ / SPEED > 15,5 mm/sec**

Realizzabili con corse comprese fra 50 a 1500 mm / Available with strokes from 50 to 1500 mm

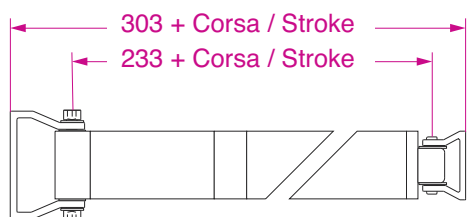

Lunghezza attuatore chiuso  
Length of the closed strut

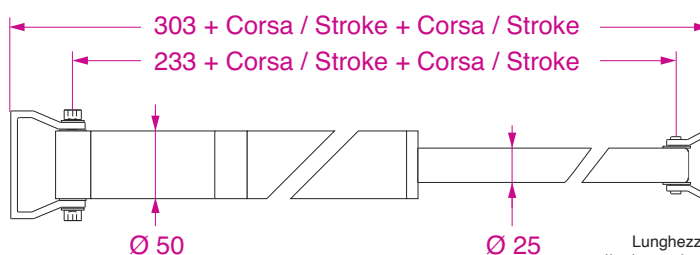

Lunghezza attuatore esteso  
Length of the extended strut

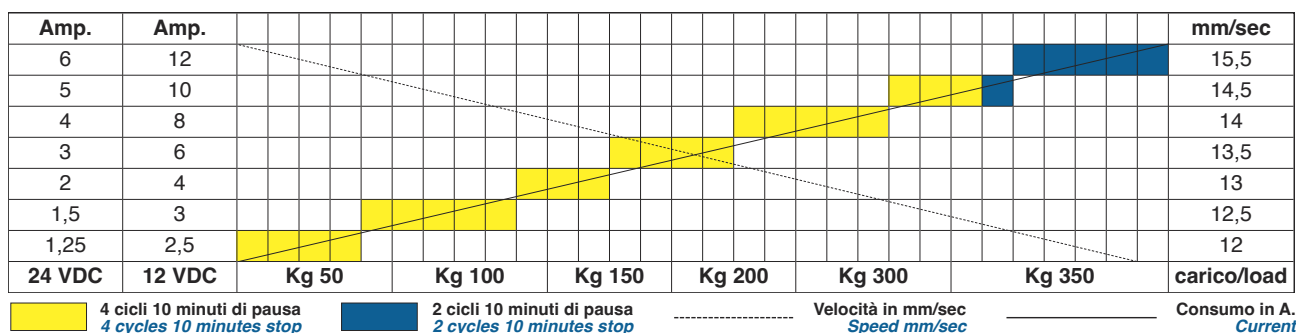

Versioni **DOPPIO EFFETTO / PUSH-PULL** version

Disponibile la versione per il montaggio in **coppia**. / Available as a **pair**.

Forniti con una **centralina elettronica** di controllo e protezione per ogni attuatore. / Supplied with an **electronic control box** for each strut to control.

**Cavo di alimentazione da 1,30 m.** / 1.30 m power cable.

A richiesta **sensori di fine corsa** regolabili. / On request adjustable **magnetic end of stroke**.

Per l'impiego occorre aggiungere un interruttore a 3 posizioni con ritorno automatico a zero. / It's necessary to add a 3 positions switch with automatic return to the OFF state.

Il cablaggio consente, se necessario, l'impiego di un **avvisatore di movimento acustico/luminoso**. An **acoustic/flashing movement** warning is available on request.

A richiesta versioni a **12 o 24 VCC**. / Available for **12 or 24 VDC** power.

**Kit per comando da remoto** opzionale / **Remote control** unit (optional)

Versioni con e senza **ENCODER** / With or without **ENCODER** version.

Disponibile a richiesta cavo di **prolunga da 2-5-8 m**. / Optional **extension cable** of 2 - 5 or 8 m.

**Passa paratia** opzionale per i nostri cavi con connettore. / **Through bulkhead gland** for BARKA's cables with plug (optional)

Articolo Item	Installazione Mounting	Effetto Push	Sincronizzazione Synchronization	Corsa Stroke	Volt	Peso Weight	Codice Code
4C480/12		doppio effetto / push-pull		480 mm	12	4 Kg	cod. 09.56.04801
4C480/24		doppio effetto / push-pull		480 mm	24	4 Kg	cod. 09.56.04802
ES4C480/2/12	coppia / pair	doppio effetto / push-pull	encoder	480 mm	12	6 Kg	cod. 09.62.04801
ES4C480/2/24	coppia / pair	doppio effetto / push-pull	encoder	480 mm	24	6 Kg	cod. 09.62.04802



Corpo, pistone e staffe in alluminio anodizzato  
Cylinder, piston and brackets in anodized light alloy

Tutte le misure sono espresse in mm / All measurements are in millimeters

# SPINTA / THRUST 4500 N (450 KG)

## VELOCITÀ / SPEED > 9,5 mm/sec

Realizzabili con corse comprese fra 50 a 1500 mm / Available with strokes from 50 to 1500 mm

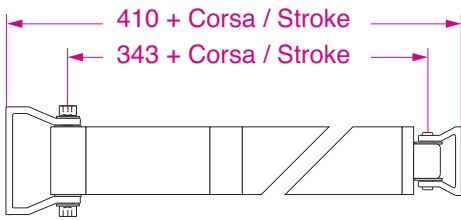

Lunghezza attuatore chiuso  
Length of the closed strut

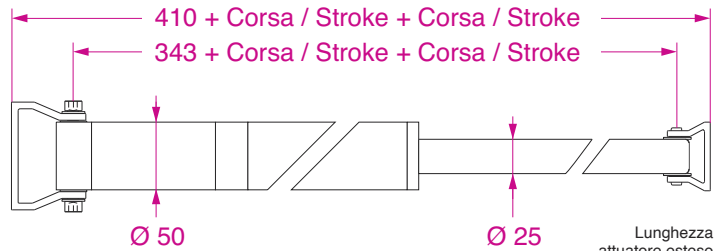

Lunghezza attuatore esteso  
Length of the extended strut

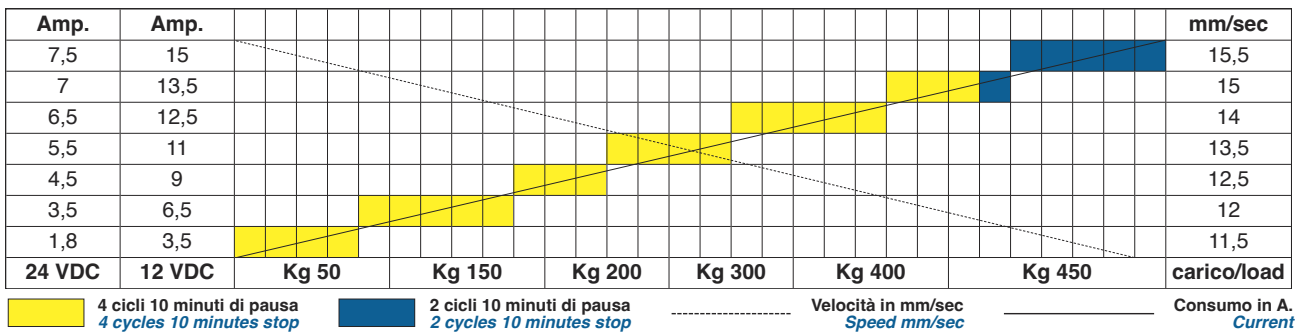

Versioni **DOPPIO EFFETTO / PUSH-PULL** version

Disponibile la versione per il montaggio **in coppia**. / Available as a **pair**.

Forniti con una **centralina elettronica** di controllo e protezione per ogni attuatore. / Supplied with an **electronic control box** for each strut to control.

**Cavo di alimentazione da 1,30 m. / 1.30 m power cable.**

A richiesta **sensori di fine corsa** regolabili. / On request adjustable **magnetic end of stroke**.

Per l'impiego occorre aggiungere un interruttore a 3 posizioni con ritorno automatico a zero. / It's necessary to add a 3 positions switch with automatic return to the OFF state.

Il cablaggio consente, se necessario, l'impiego di un **avvisatore di movimento acustico/luminoso**. An **acoustic/flashing movement** warning is available on request.

A richiesta versioni a **12 o 24 VCC**. / Available for **12 or 24 VDC power**.

**Kit per comando da remoto** opzionale / **Remote control unit** (optional)

Versioni con e senza **ENCODER** / With or without **ENCODER** version.

Disponibile a richiesta cavo di **prolunga da 2-5-8 m**. / Optional **extension cable of 2 - 5 or 8 m**.

**Passa paratia** opzionale per i nostri cavi con connettore. / **Through bulkhead gland** for BARKA's cables with plug (optional)

Articolo Item	Installazione Mounting	Effetto Push	Sincronizzazione Synchronization	Corsa Stroke	Volt	Peso Weight	Codice Code
4D4704/12		doppio effetto / push-pull		470 mm	12		cod. 09.82.04701
4D4704/24		doppio effetto / push-pull		470 mm	24		cod. 09.82.04702
ES4D4704/2/12	coppia / pair	doppio effetto / push-pull	encoder	470 mm	12	10 Kg	cod. 09.83.04705
ES4D4704/2/24	coppia / pair	doppio effetto / push-pull	encoder	470 mm	24	10 Kg	cod. 09.83.04706



Tutte le misure sono espresse in mm / All measurements are in millimeters

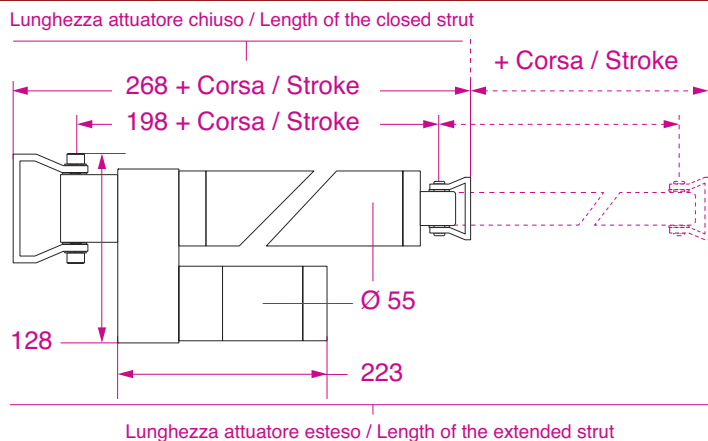

Attuatori progettati con motore laterale per diminuire l'ingombro in lunghezza e migliorare l'angolo di spinta. Struts designed with side-mounted engine to shorten length and improve the angle of thrust.

Articolo Item	Installazione Mounting	Effetto Push	Sincronizzazione Synchronization	Corsa Stroke	Volt	Peso Weight	Codice Code
4DL3004/12		doppio effetto / push-pull		300 mm	12		cod. 09.82.13001
4C480/24		doppio effetto / push-pull		300 mm	24		cod. 09.82.13002
ES4C480/2/12	coppia / pair	doppio effetto / push-pull	encoder	300 mm	12		cod. 09.83.13005
ES4C480/2/24	coppia / pair	doppio effetto / push-pull	encoder	300 mm	24		cod. 09.83.13006



Tutte le misure sono espresse in mm / All measurements are in millimeters







## SPINTA / THRUST 10000 N (1000 KG)

**VELOCITÀ / SPEED > 3,8 mm/sec**

Realizzabili a richiesta con corse fino a 300 mm / Available on request with strokes up to 300 mm

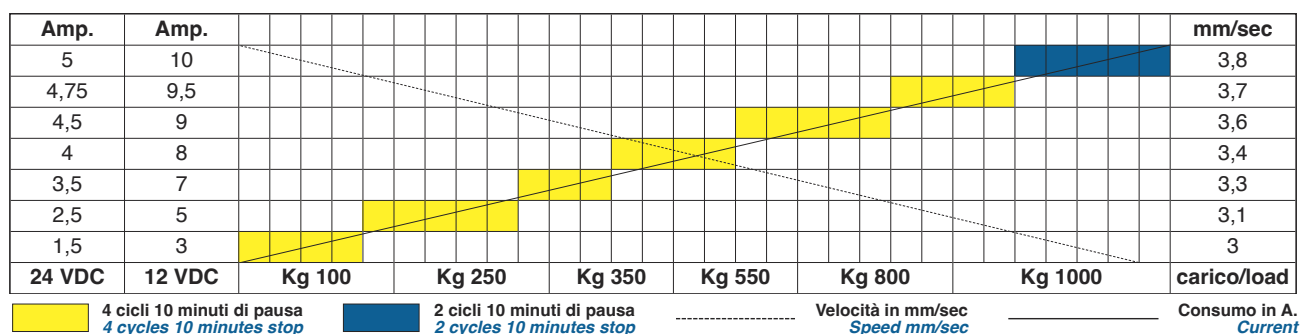
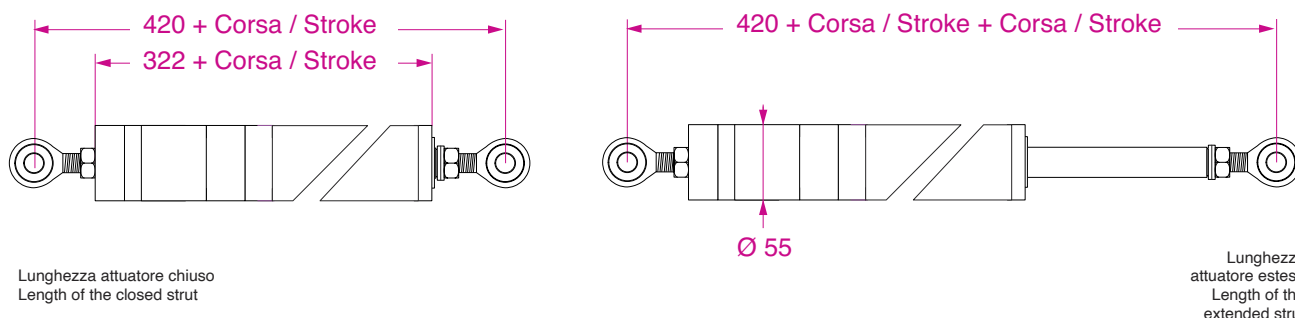

Versioni **DOPPIO EFFETTO / PUSH-PULL** version

Disponibile la versione per il montaggio **in coppia**. / Available as a pair.

Forniti con una **centralina elettronica** di controllo e protezione per ogni attuatore. / Supplied with an **electronic control box** for each strut to control.

**Cavo di alimentazione da 1,30 m.** / 1.30 m power cable.

A richiesta **sensori di fine corsa** regolabili. / On request adjustable **magnetic end of stroke**.

Per l'impiego occorre aggiungere un interruttore a 3 posizioni con ritorno automatico a zero. / It's necessary to add a 3 positions switch with automatic return to the OFF state.

Il cablaggio consente, se necessario, l'impiego di un **avvisatore di movimento acustico/luminoso**. An **acoustic/flushing movement** warning is available on request.

A richiesta versioni a **12 o 24 VCC**. / Available for **12 or 24 VDC power**.

**Kit per comando da remoto** opzionale / **Remote control** unit (optional)

Dotati di **ENCODER** / Equipped with **ENCODER** version.

Disponibile a richiesta cavo di **prolunga da 2-5-8 m**. / Optional **extension cable of 2 - 5 or 8 m**.

**Passa paratia** opzionale per i nostri cavi con connettore. / **Through bulkhead gland** for BARKA's cables with plug (optional)

Articolo Item	Installazione Mounting	Effetto Push	Sincronizzazione Synchronization	Corsa Stroke	Volt	Peso Weight	Codice Code
ES4F1509/12		doppio effetto / push-pull	encoder	150 mm	12		cod. 09.88.00019
ES4F1509/24		doppio effetto / push-pull	encoder	150 mm	24		cod. 09.88.00020
ES4F1509/2/12	coppia / pair	doppio effetto / push-pull	encoder	150 mm	12		cod. 09.88.00021
ES4F1509/2/24	coppia / pair	doppio effetto / push-pull	encoder	150 mm	24		cod. 09.88.00022



Tutte le misure sono espresse in mm / All measurements are in millimeters

# SPINTA / THRUST 1000 N (100 KG)

VELOCITÀ / SPEED > 36 mm/sec

Realizzabili con corse comprese fra 100 a 2900 mm / Available with strokes from 100 to 2900 mm

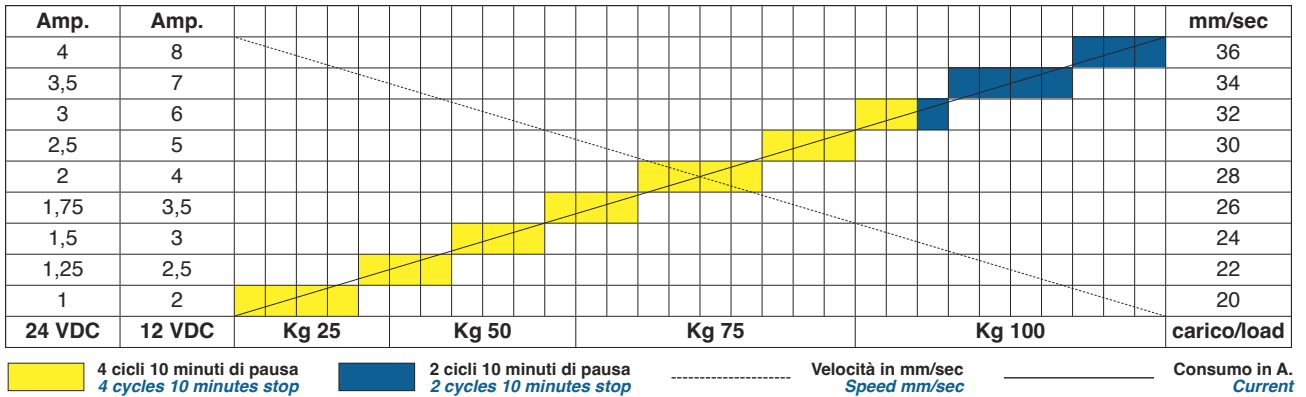

**VERSIONI VELOCI:** IDEALI PER LA MOVIMENTAZIONE DI STRUTTURE A CORSA LUNGA GRAZIE ALL'ALTA VELOCITÀ DI TRASLAZIONE, NON ADATTI AL SOLLEVAMENTO. È ESSENZIALE CHE GLI ATTUATORI LUNGHII VENGANO OPPORTUNAMENTE SOSTENUTI SE POSIZIONATI ORIZZONTALMENTE PER EVITARE CHE FLETTANO.

**HIGH SPEED VERSIONS:** IDEAL FOR HANDLING STRUCTURES WITH LONG STROKE DUE TO THEIR HIGH TRAVEL SPEED, NOT SUITABLE FOR LIFTING. IT IS ESSENTIAL THAT LONG STRUTS ARE PROPERLY INCURRED IF POSITIONED HORIZONTALLY TO PREVENT FLEX. EQUIPPED WITH MAGNETIC LIMIT.

Versioni **DOPPIO EFFETTO / PUSH-PULL** version

Disponibile la versione per il montaggio **in coppia**. / Available as a **pair**.

Forniti con una **centralina elettronica** di controllo e protezione per ogni attuatore. / Supplied with an **electronic control box** for each strut to control.

**Cavo di alimentazione da 1,30 m.** / **1.30 m power cable.**

A richiesta **sensori di fine corsa** regolabili. / On request adjustable **magnetic end of stroke**.

Per l'impiego occorre aggiungere un interruttore a 3 posizioni con ritorno automatico a zero. / It's necessary to add a 3 positions switch with automatic return to the OFF state.

Il cablaggio consente, se necessario, l'impiego di un **avvisatore di movimento acustico/luminoso**. An **acoustic/flashing movement** warning is available on request.

A richiesta versioni a **12 o 24 VCC**. / Available for **12 or 24 VDC power**.

**Kit per comando da remoto** opzionale / **Remote control unit** (optional)

Disponibile a richiesta cavo di **prolunga da 2-5-8 m**. / Optional **extension cable of 2 - 5 or 8 m**.

**Passa paratia** opzionale per i nostri cavi con connettore. / **Through bulkhead gland** for BARKA's cables with plug (optional)



Tutte le misure sono espresse in mm / All measurements are in millimeters

CON / WITH ENCODER

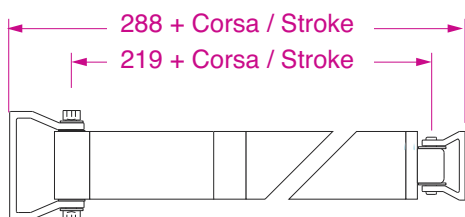

Lunghezza attuatore chiuso  
Length of the closed strut

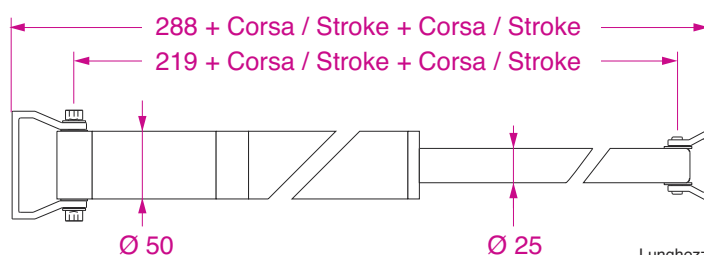

Lunghezza  
attuatore esteso  
Length of the  
extended strut

Articolo Item	Installazione Mounting	Effetto Push	Sincronizzazione Synchronization	Corsa Stroke	Volt	Peso Weight	Codice Code
ES709701/12		doppio effetto / push-pull	encoder	970 mm	12		cod. 09.68.09701
ES709701/24		doppio effetto / push-pull	encoder	970 mm	24		cod. 09.68.09702
ES709701/2/12	coppia / pair	doppio effetto / push-pull	encoder	970 mm	12	12 Kg	cod. 09.70.09701
ES709701/2/24	coppia / pair	doppio effetto / push-pull	encoder	970 mm	24	12 Kg	cod. 09.70.09702
ES714701/12		doppio effetto / push-pull	encoder	1470 mm	12		cod. 09.68.14701
ES714701/24		doppio effetto / push-pull	encoder	1470 mm	24		cod. 09.68.14702
ES714701/2/12	coppia / pair	doppio effetto / push-pull	encoder	1470 mm	12		cod. 09.70.14701
ES714701/2/24	coppia / pair	doppio effetto / push-pull	encoder	1470 mm	24		cod. 09.70.14702
ES719701/12		doppio effetto / push-pull	encoder	1970 mm	12		cod. 09.68.19701
ES719701/24		doppio effetto / push-pull	encoder	1970 mm	24		cod. 09.68.19702
ES719701/2/12	coppia / pair	doppio effetto / push-pull	encoder	1970 mm	12		cod. 09.70.19701
ES719701/2/24	coppia / pair	doppio effetto / push-pull	encoder	1970 mm	24		cod. 09.70.19702

FINE CORSA MAGNETICI / MAGNETIC END OF STROKE

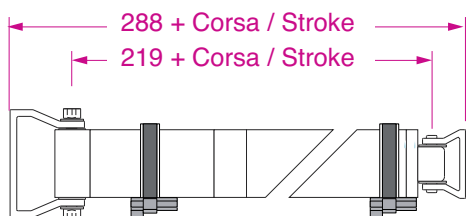

Lunghezza attuatore chiuso  
Length of the closed strut

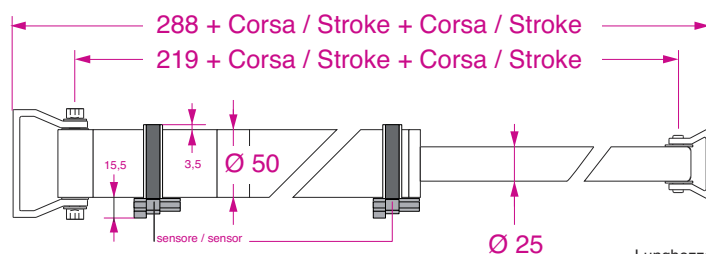

Lunghezza  
attuatore esteso  
Length of the  
extended strut

Articolo Item	Installazione Mounting	Effetto Push	Sincronizzazione Synchronization	Corsa Stroke	Volt	Peso Weight	Codice Code
709701/F/12		doppio effetto / push-pull		970 mm	12	5 Kg	cod. 09.64.09701
709701/F/24		doppio effetto / push-pull		970 mm	24	5 Kg	cod. 09.64.09702
709701/F/C/12	coppia / pair	doppio effetto / push-pull		970 mm	12		cod. 09.66.09701
709701/F/C/24	coppia / pair	doppio effetto / push-pull		970 mm	24		cod. 09.66.09702
714701/F/12		doppio effetto / push-pull		1470 mm	12		cod. 09.64.14701
714701/F/24		doppio effetto / push-pull		1470 mm	24		cod. 09.64.14702
714701/F/C/12	coppia / pair	doppio effetto / push-pull		1470 mm	12		cod. 09.66.14701
714701/F/C/24	coppia / pair	doppio effetto / push-pull		1470 mm	24		cod. 09.66.14702
719701/F/12		doppio effetto / push-pull		1970 mm	12		cod. 09.64.19701
719701/F/24		doppio effetto / push-pull		1970 mm	24		cod. 09.64.19702
719701/F/C/12	coppia / pair	doppio effetto / push-pull		1970 mm	12		cod. 09.66.19701
719701/F/C/24	coppia / pair	doppio effetto / push-pull		1970 mm	24		cod. 09.66.19702

Tutte le misure sono espresse in mm / All measurements are in millimeters

# SPINTA / THRUST 1500 N (150 KG)

**VELOCITÀ / SPEED > 16 mm/sec**

Realizzabili con corse 350 - 400 - 500 mm / Available with strokes 350 - 400 - 500 mm

Amp.	Amp.											mm/sec
4	8											16
3,5	7											15
3	6											14
2,5	5											13
2	4											12
1,75	3,5											11
1,5	3											10
1,25	2,5											9
1	2											8
<b>24 VDC</b>	<b>12 VDC</b>	<b>Kg 25</b>		<b>Kg 60</b>		<b>Kg 100</b>			<b>Kg 150</b>			<b>carico/load</b>

4 cicli 10 minuti di pausa / 4 cycles 10 minutes stop
  2 cicli 10 minuti di pausa / 2 cycles 10 minutes stop
  Velocità in mm/sec / Speed mm/sec
  Consumo in A. / Current

L'ESPERIENZA ACCUMULATA IN ANNI NELLA PRODUZIONE DI ATTUATORI PER IL SETTORE NAUTICO CI HA PORTATO A REALIZZARE UNA GAMMA DI ATTUATORI A DOPPIO EFFETTO (SPINGI E TIRA), **A DUE STADI**, UNICI NEL LORO GENERE PER L'INGOMBRO RIDOTTO RISPETTO ALLA CORSA. OUR EXPERTISE BUILT IN 15 YEARS OF PRODUCTION OF ELECTRIC STRUTS FOR THE NAUTICAL SECTOR, HAS ENABLED US TO INTRODUCE A RANGE OF TELESCOPIC, **TWO STAGES**, PUSH AND PULL STRUTS, OUTSTANDING FOR **THE REDUCED LENGTH/STROKE RATIO**.

REALIZZATI IN ALLUMINIO ANTICORODAL ANODIZZATO PER AVERE LA MASSIMA RESISTENZA ALLA CORROSIONE, **CON CAPACITÀ DI SPINTA DI 150 KG**, ADATTI A MOVIMENTARE STRUTTURE PESANTI. PRODOTTI ANCHE CON ENCODER PER UNA GESTIONE TOTALE DEI FINECORSA E IMPOSTAZIONE DI TRASLAZIONI AUTOMATICHE. NELLE VERSIONI CON ENCODER POSSIBILITÀ DI INSTALLAZIONE IN COPPIA IN VERSIONE **SINCRO** E CON PIÙ COPPIE IN **MACRO** MOVIMENTAZIONI, IL TUTTO GESTIBILE DA SEMPLICE PULSANTIERA.

MADE WITH A BODY IN ANTICORODAL ANODIZED ALUMINUM AND STAINLESS STEEL WORMS, TO PROVIDE THE MAXIMUM RESISTANCE TO CORROSION, GRANT A PUSH AND PULL POWER OF 150 KG. MADE WITHOUT AND WITH ENCODER, THE LATEST ALLOWS TO HANDLE **ELECTRONICALLY THE END OF STROKE** AND THE AUTOMATIC TRANSLATION POINTS. THE ENCODED VERSIONS CAN BE INSTALLED AS ONE SYNCHRONIZED PAIR OR AS MORE PAIRS TO BE HANDLED IN A CONCATENATED CHAIN, ALL THAT OPERATED FROM A SIMPLE KEYBOARD.

Corpo pistone e staffe in alluminio anodizzato. Versione a doppio effetto (spingi e tira). / Body and brackets made in anodized light alloy. Push and pull version.

Per proteggere il motore da sgocciolamenti la sezione più piccola deve essere in basso. / To protect the motor from dripping water in an exposed location the smaller section must be the lower.

Attuatore con un **piccolo ingombro in rapporto alla corsa**, pertanto adatto alle situazioni complicate.

**Space-saving struts, if compared with the stroke**, therefore suitable for complex installations.

Forniti con una **centralina elettronica di controllo e protezione** per ogni attuatore, di **sensori di fine corsa regolabili e cavo di alimentazione da 1,30 m**.

**Supplied with an electronic control box for each strut to control, protect against the overloads and 1.30 m power cable.**

Per l'impiego occorre aggiungere un **interruttore a 3 posizioni** con ritorno automatico a zero.

It's necessary to **add a 3 positions switch** with automatic return to the OFF state.

Il cablaggio consente, se necessario, l'impiego di un **avvisatore di movimento acustico/luminoso** (opzionale).

It's possible, when needed, to install a **movement warning device, acoustic and/or flashing.**

A richiesta versioni a **12 o 24 VCC**. / Available for **12 or 24 VDC power**.

## VERSIONI CON ENCODER / VERSIONS WITH ENCODER

Prevedono l'inserimento di **fine corsa elettronici** e consentono la predisposizione di 4 punti di stop intermedi.

Allows the set-up of **electronic end of stroke** and to insert up to a maximum of 4 intermediate arrest points.

Possono essere utilizzati per **coppie sincronizzate** o per gruppi di un massimo di 6 attuatori. / Can be used to **synchronize a pair** or for groups made of a maximum of 6 struts.

Forniti con una **tastiera** per la regolazione preventiva e l'azionamento normale. / Supplied with a **keyboard** for the set-up and the normal use.

E' possibile aggiungere un **interruttore a tre posizioni**, con ritorno automatico a zero, per sostituire la tastiera nell'uso quotidiano.

It's possible to install a **3 positions switch** to replace the keyboard for routine operations.

Il cablaggio consente, se necessario, l'impiego di un **avvisatore di movimento acustico/luminoso** (opzionale).

It's possible, when needed, to install a **movement warning device, acoustic and/or flashing.**

A richiesta versioni a **12 o 24 VCC**. / Available for **12 or 24 VDC power**.

Disponibile a richiesta cavo di prolunga da 2-5-8 m. / Optional extension cable of 2 - 5 or 8 m.



Tutte le misure sono espresse in mm / All measurements are in millimeters

**ATTUATORE ELETTRICO / ELECTRIC STRUT > CORSA / STROKE 350 mm**

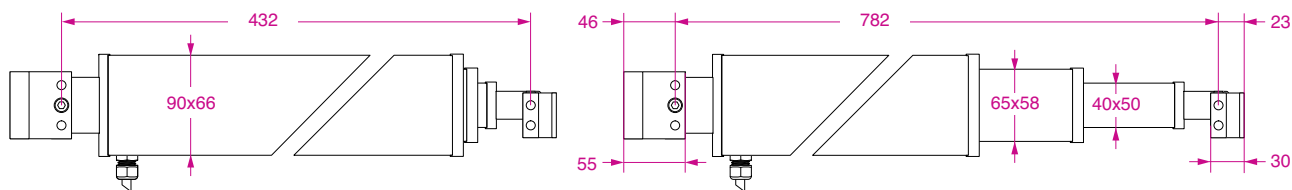

lunghezza attuatore chiuso / length of the closed strut

lunghezza attuatore esteso / length of the extended strut

Articolo Item	Installazione Mounting	Effetto Push	Sincronizzazione Synchronization	Corsa Stroke	Volt	Peso Weight	Codice Code
20350/12		doppio effetto / push-pull		350 mm	12		cod. 09.95.00001
20350/24		doppio effetto / push-pull		350 mm	24		cod. 09.95.00002
ES20350/12		doppio effetto / push-pull	encoder	350 mm	12		cod. 09.95.00101
ES20350/24		doppio effetto / push-pull	encoder	350 mm	24		cod. 09.95.00102
ES20350/2/12	coppia / pair	doppio effetto / push-pull	encoder	350 mm	12		cod. 09.95.00201
ES20350/2/24	coppia / pair	doppio effetto / push-pull	encoder	350 mm	24		cod. 09.95.00202

**ATTUATORE ELETTRICO / ELECTRIC STRUT > CORSA / STROKE 400 mm**

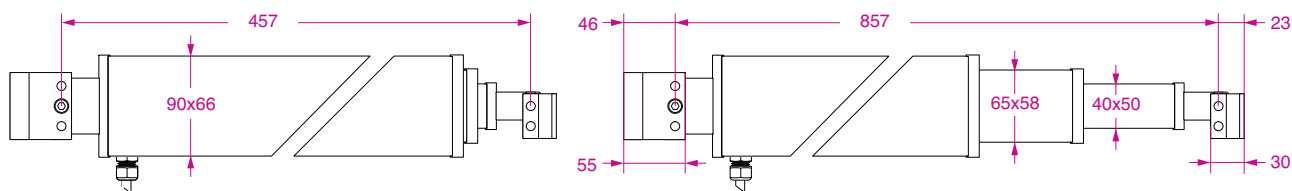

lunghezza attuatore chiuso / length of the closed strut

lunghezza attuatore esteso / length of the extended strut

Articolo Item	Installazione Mounting	Effetto Push	Sincronizzazione Synchronization	Corsa Stroke	Volt	Peso Weight	Codice Code
20400/12		doppio effetto / push-pull		400 mm	12		cod. 09.95.00003
20400/24		doppio effetto / push-pull		400 mm	24		cod. 09.95.00004
ES20400/12		doppio effetto / push-pull	encoder	400 mm	12		cod. 09.95.00103
ES20400/24		doppio effetto / push-pull	encoder	400 mm	24		cod. 09.95.00104
ES20400/2/12	coppia / pair	doppio effetto / push-pull	encoder	400 mm	12		cod. 09.95.00203
ES20400/2/24	coppia / pair	doppio effetto / push-pull	encoder	400 mm	24		cod. 09.95.00204

**ATTUATORE ELETTRICO / ELECTRIC STRUT > CORSA / STROKE 500 mm**

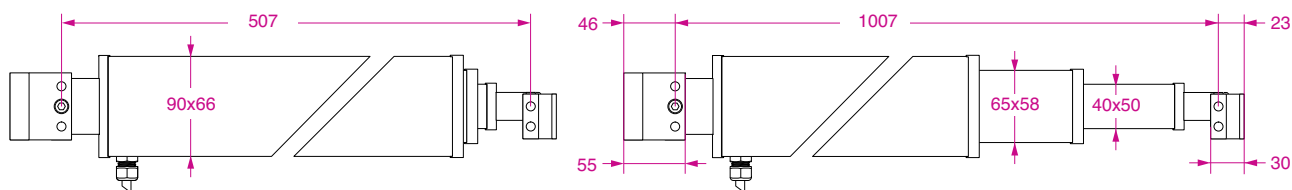

lunghezza attuatore chiuso / length of the closed strut

lunghezza attuatore esteso / length of the extended strut

Articolo Item	Installazione Mounting	Effetto Push	Sincronizzazione Synchronization	Corsa Stroke	Volt	Peso Weight	Codice Code
20500/12		doppio effetto / push-pull		500 mm	12		cod. 09.95.00005
20500/24		doppio effetto / push-pull		500 mm	24		cod. 09.95.00006
ES20500/12		doppio effetto / push-pull	encoder	500 mm	12		cod. 09.95.00105
ES20500/24		doppio effetto / push-pull	encoder	500 mm	24		cod. 09.95.00106
ES20500/2/12	coppia / pair	doppio effetto / push-pull	encoder	500 mm	12		cod. 09.95.00205
ES20500/2/24	coppia / pair	doppio effetto / push-pull	encoder	500 mm	24		cod. 09.95.00206

Tutte le misure sono espresse in mm / All measurements are in millimeters

# SPINTA / THRUST 1000 N (100 KG)

VITE A VISTA / OPEN WORM

VELOCITÀ / SPEED > 36 mm/sec

Realizzabili con corse comprese fra 200 a 2900 mm / Available with strokes from 200 to 2900 mm

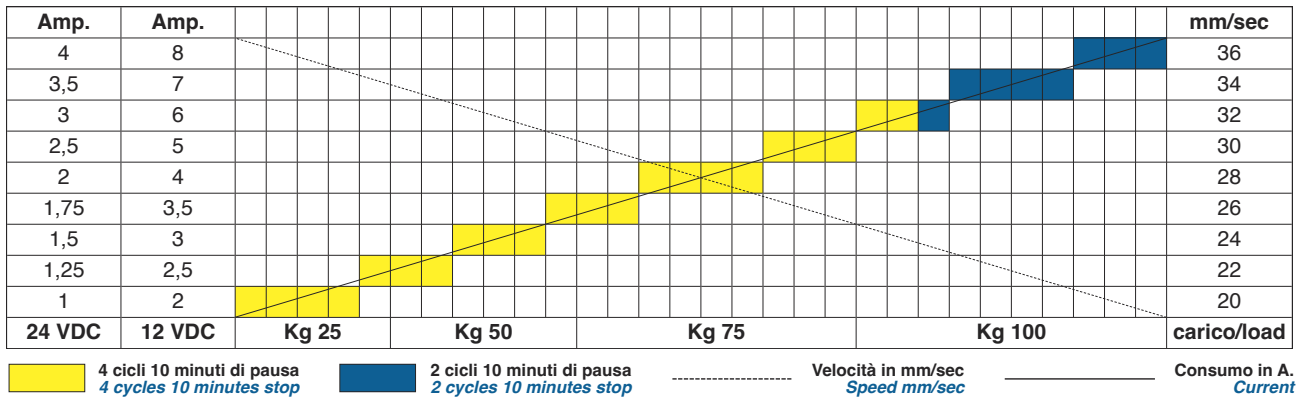

## CORSA E VOLTAGGIO A RICHIESTA / STROKE AND VOLTAGE ON REQUEST

STUDIATI PER LA MOVIMENTAZIONE DI TETTUCCHI, FINESTRATURE, PORTE, DOVE È INDISPENSABILE IL MINIMO INGOMBRO.  
 ENGINEERED TO MOVE ROOFS, WINDOWS, DOORS, WHERE A SHORTER SIZE IS A PREMIUM.  
 REALIZZATI CON VITE TRASLANTE IN ACCIAIO INOX A PROFILO SFERICO Ø 20 MM CON MADREVITE IN POM PER SFRUTTARE LE SUE BUONE PROPRIETÀ DI SCORREVOLEZZA. / REALIZED IN STAINLESS STEEL WITH A BALL SCREW PROFILE OF 20 MM DIAMETER, CARRIAGE MADE IN POM.

Versioni **DOPPIO EFFETTO / PUSH-PULL** version  
 Disponibile la versione per il montaggio in **coppia**. / Available as a **pair**.  
**Cavo di alimentazione da 1,30 m. / 1.30 m power cable.**  
 A richiesta versioni a **12 o 24 VCC**. / Available for **12 or 24 VDC** power.

## USCITA CAVO LATERALE / SIDE CABLE OUTLET > E400001 VX

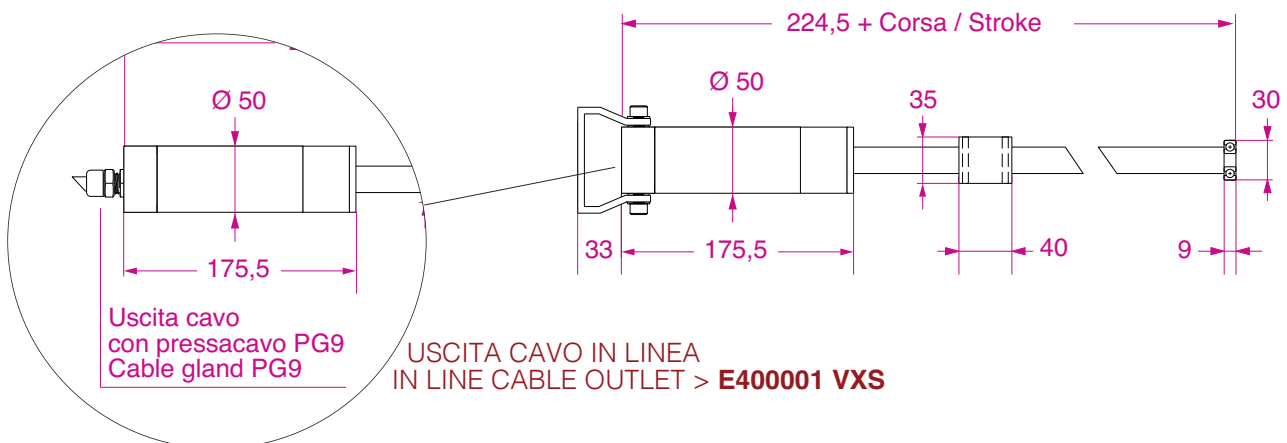

E400001 VX	uscita cavo laterale / side cable outlet	cod. 09.13.00100
E400001 VXS	uscita cavo in linea / in line cable outlet	cod. 09.13.00200



Tutte le misure sono espresse in mm / All measurements are in millimeters





## VERSIONI DA INTERNO / INDOOR VERSIONS

- Telescopici a doppio stadio
  - Vengono prodotti con corse di **500, 650 o 800 mm**, per fissaggio a pavimento o a paratia.
  - Ingombro verticale inferiore alla corsa: ciò minimizza la profondità necessaria per il vano che contiene il televisore.
  - Dotato di encoder che consente di stabilire elettronicamente i punti di partenza e di arrivo: si evita la necessità di un posizionamento meccanico in altezza estremamente preciso.
  - Il sistema di staffaggio si **adatta a tutti i modelli di televisori** grazie alle infinite possibilità di regolazione.
  - **È possibile alzare le staffe di fissaggio fino a 36 cm**: utile quando la profondità del vano supera l'altezza del televisore.
  - Fornito con una tastiera di regolazione e comando.
  - Previsto l'impiego di un telecomando (opzionale).
  - Il cablaggio consente, se necessario, l'impiego di un avvisatore di movimento acustico/luminoso (opzionale).
  - A richiesta versioni per alimentazione a 12 o 24V CC.
- 
- Two stages telescopic
  - Available with a stroke of **500 - 650 or 800 mm**
  - Its minimum height is less then the available stroke: the depth of the locker for the TV don't needs to exceed the chosen stroke.
  - Equipped with an encoder that allows the electronic set-up of the end of stroke positions: that avoids the need of a very precise choice of the installation height.
  - The adjustable brackets for the the TV fixing **can be adapted to every type of TV** thanks to the endless possibilities of configuration.
  - It's also **possible to lift up to 36 cm** the fixing brackets of the TV: that's useful when the depth of the locker exceed the height of the TV.
  - Supplied with a keyboard for set-up lifting and lowering command.
  - A remote control is available on request.
  - An acoustic/flashing movement warning is available on request.
  - Available for 12 or 24VDC power.



Costruiti in alluminio anodizzato per l'utilizzo in ambiente marino  
Made in anodized light alloy to withstand the harsh marine environment

STAFFA REGOLABILE  
FISSAGGIO A PARATIA  
BULKHEAD MOUNTING  
ADJUSTABLE BRACKET

BASE PER  
FISSAGGIO A PAVIMENTO  
FLOOR  
MOUNTING BASE

Articolo Item	Fissaggio Mounting	Regolazione Setup	Corsa Stroke	Volt	Peso Weight	Codice Code
E170001/12	a pavimento / floor	encoder	500 mm	12		cod. 09.97.10001
E170001/24	a pavimento / floor	encoder	500 mm	24		cod. 09.97.10002
E170002/12	a pavimento / floor	encoder	650 mm	12		cod. 09.97.10003
E170002/24	a pavimento / floor	encoder	650 mm	24		cod. 09.97.10004
E170003/12	a pavimento / floor	encoder	800 mm	12		cod. 09.97.10005
E170003/24	a pavimento / floor	encoder	800 mm	24		cod. 09.97.10006
E170004/12	a paratia / bulkhead	encoder	500 mm	12		cod. 09.97.11001
E170004/24	a paratia / bulkhead	encoder	500 mm	24		cod. 09.97.11002
E170005/12	a paratia / bulkhead	encoder	650 mm	12		cod. 09.97.11003
E170005/24	a paratia / bulkhead	encoder	650 mm	24		cod. 09.97.11004
E170006/12	a paratia / bulkhead	encoder	800 mm	12		cod. 09.97.11005
E170006/24	a paratia / bulkhead	encoder	800 mm	24		cod. 09.97.11006

Tutte le misure sono espresse in mm / All measurements are in millimeters

500 mm

650 mm

800 mm

Vista frontale – aperto  
Front view – open

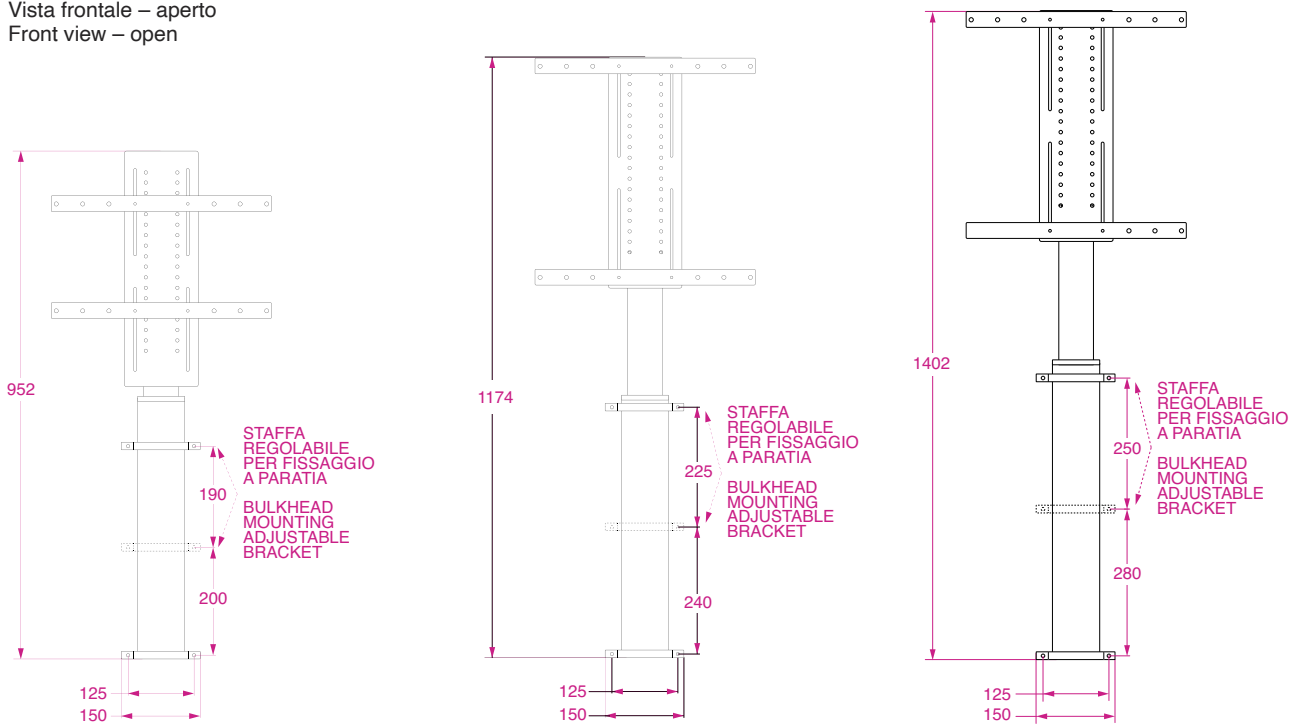

Vista frontale – chiuso  
Front view – closed

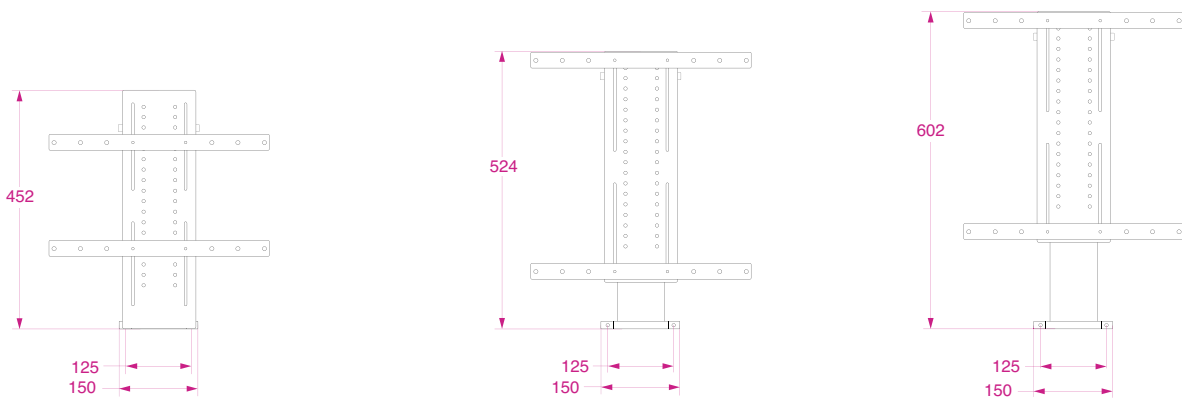

Vista laterale – chiuso  
Side view – closed

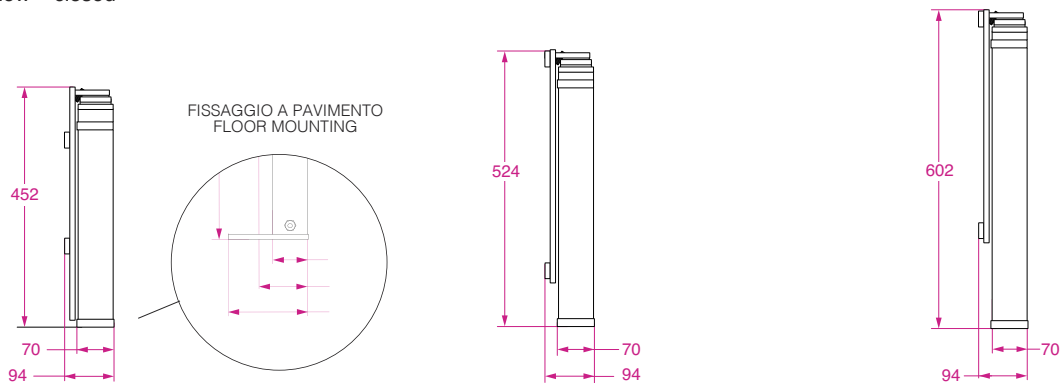

Tutte le misure sono espresse in mm / All measurements are in millimeters

## VERSIONI DA ESTERNO / OUTDOOR VERSIONS

### MOTORE IN LINEA / IN-LINE MOTOR

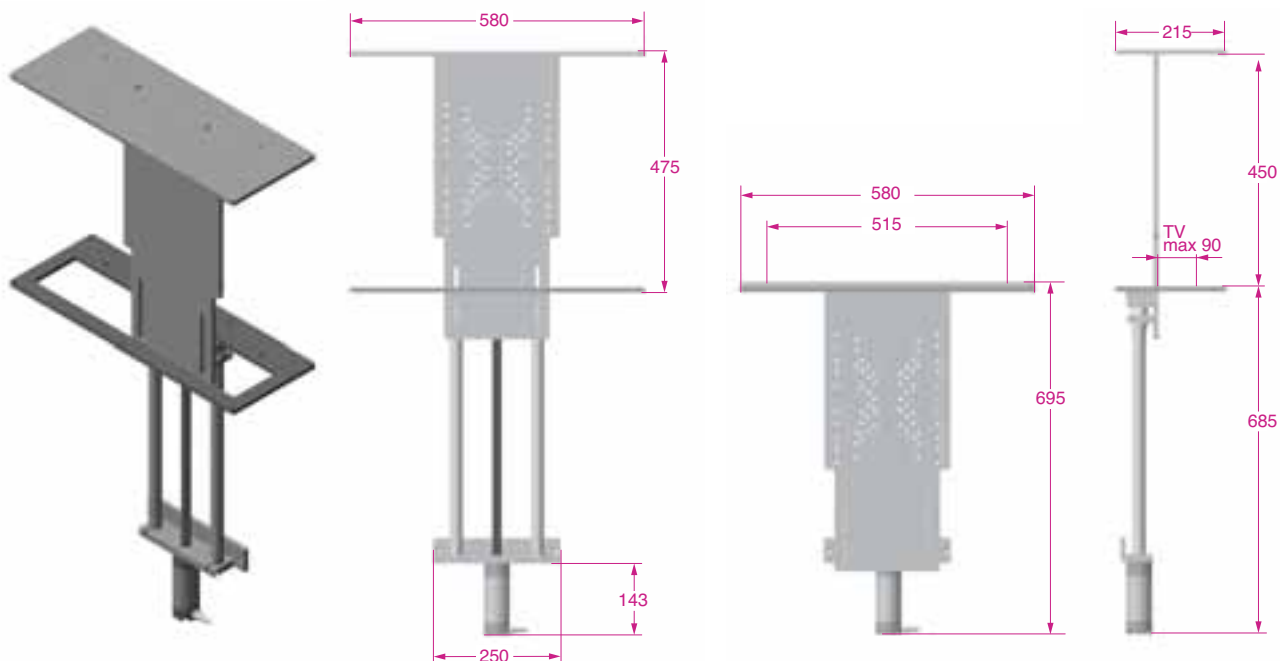

<b>184508/12</b>	12 Volt		<b>cod. 09.97.00301</b>
<b>184508/24</b>	24 Volt		<b>cod. 09.97.00302</b>
<b>E184508/12</b>	12 Volt	encoder	<b>cod. 09.97.01301</b>
<b>E184508/24</b>	24 Volt	encoder	<b>cod. 09.97.01302</b>

### MOTORE LATERALE / SIDE MOTOR

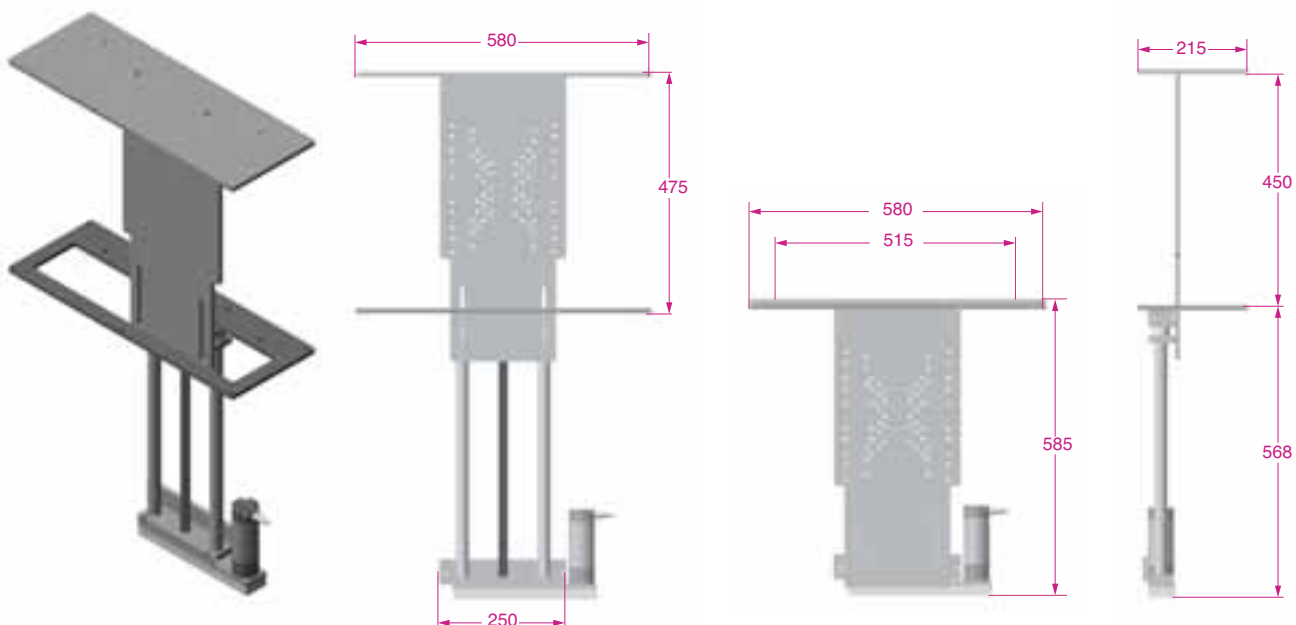

<b>184509/12</b>	12 Volt		<b>cod. 09.97.00401</b>
<b>184509/24</b>	24 Volt		<b>cod. 09.97.00402</b>
<b>E184509/12</b>	12 Volt	encoder	<b>cod. 09.97.01401</b>
<b>E184509/24</b>	24 Volt	encoder	<b>cod. 09.97.01402</b>

Tutte le misure sono espresse in mm / All measurements are in millimeters



# TEAK WONDER

TRADEMARK

TEAK WONDER



## TEAK WONDER

È IL MIGLIOR TRATTAMENTO PER IL TEAK, DA OLTRE 40 ANNI I PRODOTTI TEAK WONDER SONO LA PRIMA SCELTA DEGLI YACHTSMAN PIÙ ESPERTI E LEADER DEL MERCATO MONDIALE. IL TRATTAMENTO A TRE STADI È STATO RICONOSCIUTO COME IL MENO AGGRESSIVO MA PIÙ EFFICACE PER OTTENERE IL MEGLIO DAL VOSTRO TEAK.

THE BEST TREATMENT FOR YOUR TEAK, FOR OVER 40 YEARS TEAK WONDER HAVE BEEN THE PRODUCTS OF CHOICE FOR BOTH PROFESSIONAL AND LEISURE SAILORS AND IS THE WORLD MARKET LEADER. THE 3 STEP TREATMENT HAS BEEN RECOGNIZED AS THE MOST EFFECTIVE YET LEAST AGGRESSIVE TO GET YOUR TEAK INTO GREAT SHAPE.



### DRESSING & SEALER > TWDS

La resa è circa 5-6 mq/lt  
The coverage is approximately 5-6 Sqm/lt



**TEAK WONDER®  
DRESSING & SEALER**  
è un protettivo sicuro e durevole,  
non a base oleosa, che dona al  
tek un gradevole aspetto  
dorato senza scurirlo.  
**TEAK WONDER®  
DRESSING & SEALER**  
non puzza, non rende il tek lucido  
e/o scivoloso, non è appiccicoso  
ed asciuga rapidamente,  
non scurisce la superficie  
e non si accumula.

**TEAK WONDER®  
DRESSING & SEALER**  
is a safe and durable, non-oil  
based product which provides a  
pleasant golden colour without  
darkening the teak or producing  
that fake coloured look.

**TEAK WONDER®  
DRESSING & SEALER**  
does not make the teak glossy or  
slippery, does not darken the teak  
and does not build up an  
accumulation on the surface.

**TWDS05 x 12** Latta / tins 0,5 lt - **Confezioni / Packaging:** 12 latte per scatola / pcs per box  
**TWDS1 x 8** Latta / tins 1 lt - **Confezioni / Packaging:** 8 latte per scatola / pcs per box  
**TWDS4 x 4** Latta / tins 4 lt - **Confezioni / Packaging:** 4 latte per scatola / pcs per box

**cod. 06.02.00000**

**cod. 06.02.00001**

**cod. 06.02.00005**



## INSTANT TEAK CLEANER &gt; TWITCL

**INSTANT TEAK CLEANER**  
È un potente detergente usato per rimuovere le macchie d'unto da piccole superfici

To remove grease stains from small areas without need of rinsing thoroughly



**TWITCL x12** Bottiglia / bottle 250 ml - 12 bottiglie per scatola / pcs per box

cod. 06.02.00040

## CLEANER &gt; TWCL

## BRIGHTENER &gt; TWBR



La resa è circa 6-8 mq/lt (dipende dalle condizioni del legno)

The coverage is approximately 6-8 Sqm/Lt (depending on the condition of the wood)

**TEAK WONDER® CLEANER**  
È un potente detergente che pulisce a fondo il tek, facilmente e con poca fatica, senza che sia necessario carteggiarlo

Is a powerful cleanser that thoroughly cleans the teak easily and with very little effort, without the need for sanding

**TWCL4 x4** Flacone / bottle 4 lt - 4 flaconi per scatola / pcs for box

**TWBR4 x4** Flacone / bottle 4 lt - 4 flaconi per scatola / pcs for box

La resa è circa 8-10 mq/lt (dipende dalle condizioni del legno)

The coverage is approximately 8-10 Sqm/Lt (depending on the condition of the wood)

**TEAK WONDER® BRIGHTENER**  
È uno schiarente che serve ad eliminare dal tek le eventuali ombre che possono persistere anche dopo l'applicazione del **TEAK WONDER® CLEANER**

Is a lightening process used to eliminate shading from the teak which may still persist even after the application of the **TEAK WONDER® CLEANER**



cod. 06.02.00020

cod. 06.02.00025

## COMBO PACK &gt; TWCP

La resa è circa 6-8 mq / lt (dipende dalle condizioni del legno)  
The coverage is approximately 6-8 Sqm/lt (depending on the condition of the wood)

**TEAK WONDER® COMBO PACK**

è un kit completo per la pulizia. Le bottiglie da litro sono dotate di un pratico tappo/versatore che permette un facile utilizzo dei prodotti, evitandone gli sprechi

**TEAK WONDER® COMBO PAK**

is a complete kit for cleaning small areas. The kit contains a one litre bottle of cleaner and a one litre bottle of brightener to perform the complete cleaning cycle.

The bottles are equipped with a handy cap/pourer that allows easy use of the products, avoiding waste

**Kit comprendente: / Kit consist of:** 8 kit di bottiglie per scatola / kit for box

1 bottiglia da 1 lt di / One 1 ltr bottle of **TEAK WONDER® CLEANER**

**TWCP1 x 8** 1 bottiglia da 1 lt di / One 1 ltr bottle of **TEAK WONDER® BRIGHTENER**

cod. 06.02.00010

**Kit comprendente: / Kit consist of:** 2 kit di bottiglie per scatola / kit for box

1 bottiglia da 4 lt di / One 4 ltr bottle of **TEAK WONDER® CLEANER**

**TWCP4 x 2** 1 bottiglia da 4 lt di / One 4 ltr bottle of **TEAK WONDER® BRIGHTENER**

cod. 06.02.00015

# TEAK WONDER

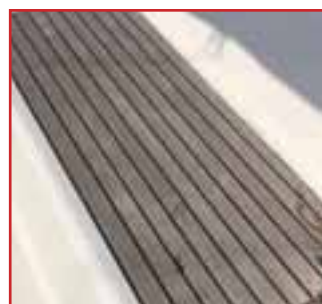





FILTRI ACQUA HYDROPURE / WATER FILTERS HYDROPURE

## FILTRI ACQUA HYDROPURE / WATER FILTERS HYDROPURE

Un problema sempre presente a bordo delle imbarcazioni da diporto è la scadente qualità dell'acqua proveniente dal serbatoio e che può essere utilizzata per uso igienico, di cucina e, talvolta, come bevanda. Mentre il problema del bere viene generalmente superato con l'utilizzo di acqua minerale, rimane pur sempre il disagio ed il pericolo generati dall'utilizzare, in cucina e per la toilette, il liquido spesso maleodorante (perchè chiamarlo acqua?), proveniente dal serbatoio. Fortunatamente ora è possibile, in maniera semplice, sicura ed economica, rendere l'acqua batteriologicamente pura, priva di sostanze in sospensione e di quei sapori ed odori sgradevoli generati da disinfettanti (cloro), dal prolungato contatto con materiali inadatti (gomma, plastica, ecc.) e dalla stagnazione. In effetti, l'immissione nel serbatoio di un prodotto disinfettante quale l'**AMUCHINA**, in occasione di ogni rifornimento, **assicurerà all'acqua una sterilità assoluta**, eliminando quei batteri che sono fonti di disagi e malattie. È poi sufficiente installare nel circuito idraulico di bordo un **HYDROPURE, speciale filtro a carbone attivo**, per eliminare ogni sapore ed odore sgradevole.

The disgusting quality of stored water for drinking, cooking and washing on board yachts and small power vessels is a well recognized problem. Bottled mineral water for drinking is only a partial and mostly inconvenient solution, leaving the crew suffering tainted food and foul washing water besides being exposed to the attendant health risks. It is now possible in a very simple and economical way to free the water of bacteria and suspended matter, and to remove the odours caused by disinfectants such as chlorine. At the same time the taste in the water from contact with rubber, plastic and other unsuitable materials can be eliminated. The disinfectant will also serve to reduce the degradation of the water when stagnated over long periods. Stage two is to pump the water through a **HYDROPURE CARBON FILTER** so that it is delivered to the tap free from odours and taste and of all suspended matter.

### FILTRO ACQUA COMPLETO DI CARTUCCIA / FILTER HOUSING WITH CARTRIDGE > HP5SCC

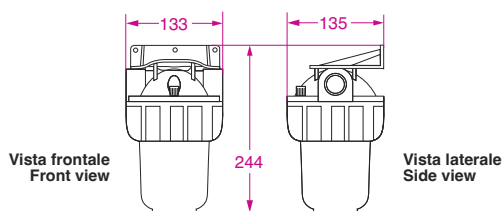

Filtro acqua, completo di cartuccia ai carboni attivi da 5".  
Raccordi d'ingresso e uscita in ottone 1/2" F GAS e staffa di supporto.

Filter housing, complete water filter with 5" activated carbon cartridge in and out connections: 1/2" F BSP brass and support bracket.

**HP5SCC**

Peso / Weight 927 g

**cod. 99.01.00001**

### FILTRO ACQUA COMPLETO DI CARTUCCIA / WATER FILTER HOUSING WITH CARTRIDGE > HP10SCC

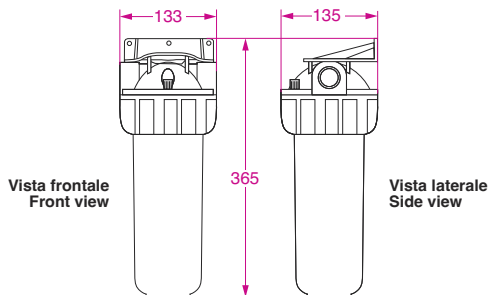

Filtro acqua, completo di cartuccia ai carboni attivi da 10".  
Raccordi d'ingresso e uscita in ottone 1/2" F GAS e staffa di supporto.

Filter housing, complete water filter with 10" activated carbon cartridge in and out connections: 1/2" F BSP brass and support bracket.

**HP10SCC**

Peso / Weight 1,2 Kg

**cod. 99.01.00002**

### CONTENITORE PER DUE CARTUCCE / DOUBLE WATER FILTER HOUSING > HP10X2

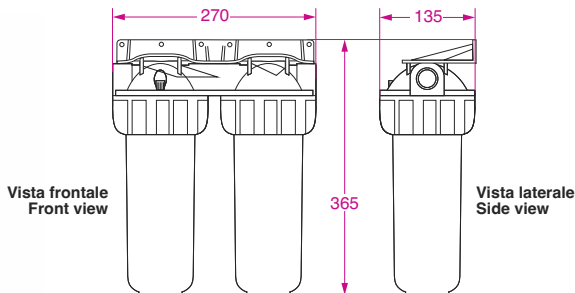

Contenitore per due cartucce filtro da 10" in tandem, con staffa.  
Raccordi d'ingresso e uscita in ottone 3/4" F GAS

Double water filter housing for two 10" cartridges in tandem (not supplied).  
In and out connections: 3/4" F BSP brass, with support bracket.

**HP10X2**

Peso / Weight 1,89 Kg

**cod. 99.01.00007**

Tutte le misure sono espresse in mm / All measurements are in millimeters

**CARTUCCIA A PERDERE AI CARBONI ATTIVI / DISPOSABLE ACTIVATED CARBON CARTRIDGE > CC5**

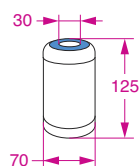

Cartuccia da 5".  
Grado di filtrazione: 25 micron.  
Portata massima 5 litri/min.

5" carbon cartridge.  
Max flow rate 5 litre/min.  
Filter > 25 micron particles.

**CC5**

Peso / Weight 160 g

**cod. 99.01.00003**

**CARTUCCIA A PERDERE AI CARBONI ATTIVI / DISPOSABLE ACTIVATED CARBON CARTRIDGE > CC10**

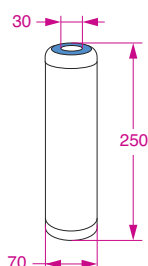

Cartuccia da 10".  
Grado di filtrazione: 25 micron.  
Portata massima 10 litri/min.

10" carbon cartridge.  
Max flow rate 10 litre/min.  
Filter > 25 micron particles.

**CC10**

Peso / Weight 350 g

**cod. 99.01.00004**

**CARTUCCIA A PERDERE / DISPOSABLE CARTRIDGE > CPP10/5**

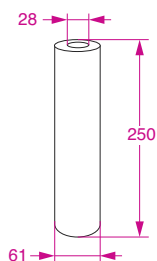

Per particelle disperse nell'acqua.  
Cartuccia in polipropilene da 10".  
Grado di filtrazione: 5 micron.  
Portata nominale 33 litri/min.

For particles contained in the water.  
10" Polypropylene.  
Filtering medium.  
Filtering capacity: 5 micron.  
Nominal flow rate 33 litre/min.

**CPP10/5**

Peso / Weight 178 g

**cod. 99.01.00009**

**CARTUCCIA A PERDERE / DISPOSABLE CARTRIDGE > CPP10/25**

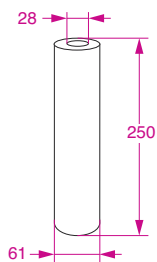

Per particelle disperse nell'acqua.  
Cartuccia in polipropilene da 10".  
Grado di filtrazione: 25 micron.  
Portata nominale 33 litri/min.

For particles contained in the water.  
10" Polypropylene.  
Filtering medium.  
Filtering capacity: 25 micron.  
Nominal flow rate 33 litre/min.

**CPP10/25**

Peso / Weight 147 g

**cod. 99.01.00010**

Tutte le misure sono espresse in mm / All measurements are in millimeters

## ACCESSORI / ACCESSORIES

### CHIAVE PER GHIERA / SPANNER FOR HYDROPURE > HP SPANNER

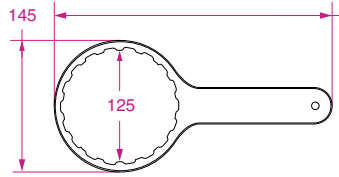

**HP SPANNER**

Peso / Weight 61 g

Facilita lo svitamento della ghiera avvitata alla testata.

It facilitates to unscrew the plastic nut holding the head.

**cod. 99.01.00029**

### STAFFA MURALE / PLASTIC BRACKET > PLBFA

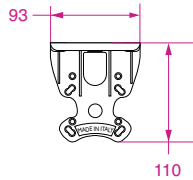

**PLBFA**

Peso / Weight 57 g

**Per filtro singolo.**  
Completa di 4 viti per il fissaggio al contenitore. Fornita in dotazione con i nostri filtri HP5SCC e HP10SCC.

**For single housing.**  
HP5 and HP10. The 4 screws for the filter housing are included.

**cod. 99.01.00022**

### STAFFA MURALE / PLASTIC BRACKET > PLBFA X2

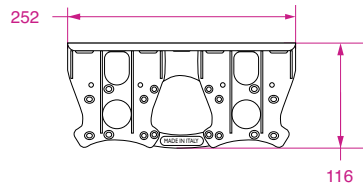

**PLBFA X2**

Peso / Weight 172 g

**Per filtro doppio.**  
Completa di 8 viti per il fissaggio al contenitore. Fornita in dotazione con i nostri contenitori HP10X2.

**For double housing.**  
The 8 screws for the filter housing are included.

**cod. 99.01.00023**

### FILTRAZIONE E ADDOLCIMENTO DELL'ACQUA / FILTRATION AND SOFTENING > ADRIATIC 5



Vista frontale  
Front view



Vista posteriore  
Rear view



Vista dall'alto  
Top view

**ADRIATIC 5**

Peso / Weight 10 Kg

Progettato per il trattamento dell'acqua utilizzata per il lavaggio di yacht e imbarcazioni. Non richiede l'uso di energia elettrica.

Washing and cleaning of every surface with extraordinary NO-SPOT effects with no calcareous residual to be removed after washing, no need for dry and cleanse. No power needed.

**cod. 99.01.00040**

### CARTUCCE DI RICAMBIO PER ADRIATIC 5 / SPARE CARTRIDGES FOR ADRIATIC 5

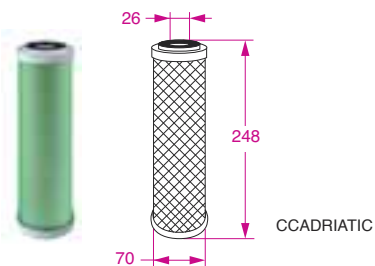

CCADRIATIC

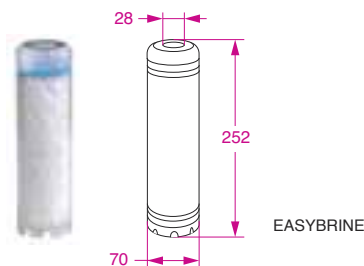

EASYBRINE

**CCADRIATIC**

**EASYBRINE**

Peso / Weight 882 g

**CCADRIATIC**  
CB-EC CTO 10 micron  
CARBON BLOCK

**EASYBRINE**  
HS-EasyBRINE  
Contenitore con sale (NaCl)  
Container with NaCl

**cod. 99.01.00041**

**cod. 99.01.00042**





## POMPE DI SENTINA MANUALI

### COMPACT 50 > POMPA DI SENTINA AD INCASSO A BASSO PROFILO



- Design compatto per gli spazi ridotti
- Solo 120 mm di spessore per una installazione ad incasso
- Fascetta bloccaggio membrana di facile rimozione per orientare i raccordi acqua e la manutenzione
- Costruzione robusta, collaudata ed affidabile
- Portata 40 litri al minuto
- Adatta al pompaggio di acqua dolce, salata e gasolio

#### Utilizzi tipici

- Pompa di sentina di emergenza
- Scarico WC

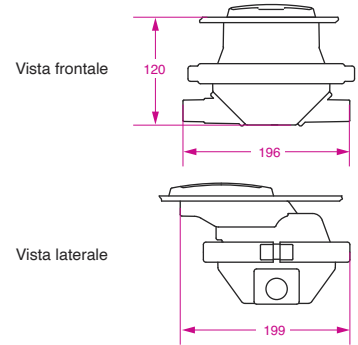

<b>Conessioni tubi</b>	Portagomma Ø 25 mm	
<b>Materiali</b>	Corpo della pompa: polipropilene rinforzato, ghiera in acetato - Membrana, valvole e guarnizioni: Nitrile - Leva: Nylon rinforzato - Diaframma passa coperta: EPDM Passa coperta in PBT - Viteria: acciaio inox	
<b>Materiali a contatto con i fluidi</b>	Polipropilene rinforzato, Nitrile, Neoprene, acciaio inox	
<b>Kit di manutenzione</b>	AK8035: kit di manutenzione per Compact 50 Contiene: Membrana, valvole e seager	
<b>Accessori</b>	AS0353: Maniglia di ricambio	
<b>Aspirazione massima</b>	3 m	
<b>Prevalenza massima</b>	4 m	
<b>DATI PRESTAZIONE</b>		
<b>Aspirazione</b>	1 m	
<b>Prevalenza</b>	0,5 m	
<b>45 colpi al minuto</b>	32 litri	
<b>70 colpi al minuto</b>	35 litri	

BP 0350

Peso 0,9 Kg

cod. 13.01.0006

### GUSHER® 10 MK 3 > POMPA DI SENTINA IN LEGA LEGGERA PRESSOFUSA



- Lega leggera pressofusa con verniciatura epossidica per garantirne una lunga durata
- Costruzione molto robusta adatta anche a condizioni estreme
- Progettata per un accesso immediato ed una facile manutenzione dalle membrane
- Portata elevata, 65 lit/min, virtualmente non intasabile
- Montaggio a paratia, a pavimento od a incasso
- Adatta a barche sopra i 12 m

#### Utilizzi tipici

- Pompa di sentina di emergenza
- Svuotamento serbatoi
- Scarico WC

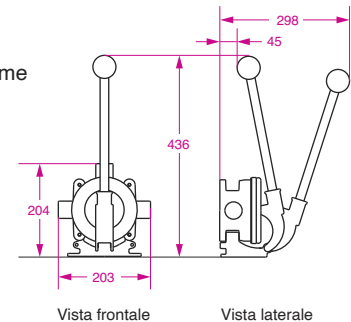

<b>Conessioni tubo</b>	Portagomma Ø 38 mm	
<b>Materiali</b>	Corpo pompa: Lega d'alluminio marino LM6 (rivestimento epossidico) Membrana: Neoprene (disponibile anche in Nitrile) - Viteria: acciaio inox	
<b>Materiali a contatto con i fluidi</b>	Lega d'alluminio marino LM6 (rivest. epossidico). Neoprene, Nitrile, acciaio inox	
<b>Kit di manutenzione</b>	AK3706: Parti in Neoprene – AK3714: Parti in Nitrile per olio e gasolio Contiene: Membrana, Valvole, Guarnizioni	
<b>Accessori</b>	DP 3804: (Optional) Passa coperta in lega leggera	
<b>Aspirazione massima</b>	4 m	
<b>Prevalenza massima</b>	4 m	
<b>DATI PRESTAZIONE</b>		
<b>Aspirazione</b>	1 m	2 m
<b>Prevalenza</b>	0,5 m	0,5 m
<b>45 colpi al minuto</b>	41 litri	41 litri
<b>70 colpi al minuto</b>	65 litri	65 litri

BP 3708

Peso 2,3 Kg

cod. 13.01.0007

Tutte le misure sono espresse in millimetri

**POMPA UNIVERSALE MK 5 WC > POMPA PER SCARICO WC**



**Utilizzi tipici**

- Scarico WC
- Svuotamento serbatoi
- Pompa di sentina di emergenza

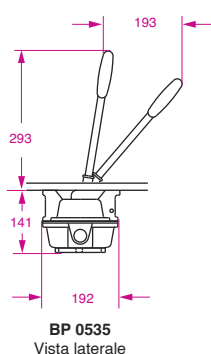

**BP 0535**  
Vista laterale

- Può essere montata in varie posizioni e orientamenti
- Membrana completamente protetta
- Il portello di ispezione facilita la manutenzione (non richiede utensili)
- Tenuta a prova di odori
- Corpo pompa bianco
- Guarnizioni in Nitrile resistenti agli agenti chimici
- Compatibile all'uso con valvole deviatrici

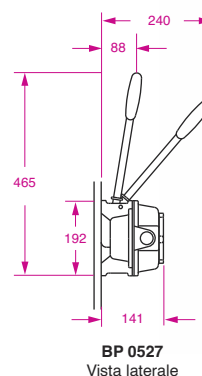

**BP 0527**  
Vista laterale

	<b>BP 0527 - A PARATIA</b>	<b>BP 0535 - SOTTOPAIOLO</b>
<b>Peso</b>	1,17 Kg	
<b>Connessioni tubi</b>	Portagomma Ø 38 mm	
<b>Materiali</b>	Corpo della pompa: Polipropilene rinforzato - Membrana, Valvole e Guarnizioni: Nitrile Leva: Acciaio inox - Viteria e clips: acciaio inox	
<b>Materiali a contatto con i fluidi</b>	Polipropilene rinforzato, Acetato, Nitrile, acciaio inox	
<b>Kit di manutenzione</b>	AK8050: Kit di manutenzione per Mk5 – Contiene: Membrane, Valvole e clips circolari	
<b>Accessori</b>	DP9906: Kit passa paratia – AS0511: Maniglia di ricambio	
<b>Aspirazione massima</b>	4,5 m	
<b>Prevalenza massima</b>	4,5 m	
<b>DATI PRESTAZIONE</b>		
<b>Aspirazione</b>	1 m	
<b>Prevalenza</b>	0,5 m	
<b>45 colpi al minuto</b>	42 litri	
<b>70 colpi al minuto</b>	66 litri	

BP 0527 a paratia  
BP 0535 sottopaiolo

cod. 13.01.00012  
cod. 13.01.00013

**POMPA UNIVERSALE MK 5 > POMPA DI SENTINA E DI TRAVASO ACQUE DI SCARICO**



**Utilizzi tipici**

- Svuotamento serbatoi
- Scarico WC
- Pompa d'emergenza
- Spostamento acqua di zavorra

**TRE DIVERSE POSIZIONI DI MONTAGGIO**

- Il portello d'ispezione consente una facile manutenzione (non necessita di utensili)
- Design robusto, collaudato ed affidabile
- Membrana super protetta
- Guarnizioni anti-odori
- Valvole praticamente non intasabili
- Elevata portata: 66 litri al minuto
- Approvata dai Lloyds (MSA) e dalla Guardia Costiera U.S.A. come pompa per scialuppe di salvataggio
- Adatta al pompaggio di acqua salata e gasolio

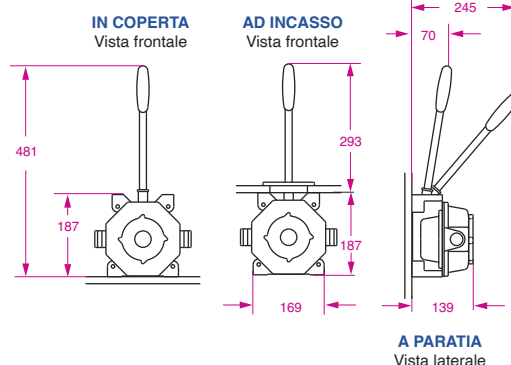

<b>Peso</b>	1,36 Kg
<b>Connessioni tubo</b>	Portagomma Ø 38 mm
<b>Materiali</b>	Corpo della pompa: Polipropilene rinforzato - Membrana, Valvole e Guarnizioni: Nitrile Leva, viteria e clips: acciaio inox
<b>Materiali a contatto con i fluidi</b>	Polipropilene rinforzato, Acetato, Nitrile, acciaio inox
<b>Kit di manutenzione</b>	AK8050: Kit di manutenzione per Mk5 – Contiene: Membrane, Valvole e clips circolari
<b>Accessori</b>	DP9906 - Kit piastra di coperta (compreso coperchio) – AS0511 - Maniglia di ricambio
<b>Aspirazione massima</b>	4,5 m
<b>Prevalenza massima</b>	4,5 m
<b>DATI PRESTAZIONE</b>	
<b>Aspirazione</b>	1 m
<b>Prevalenza</b>	0,5 m
<b>45 colpi al minuto</b>	42 litri
<b>70 colpi al minuto</b>	66 litri

BP 0510

cod. 13.01.00011

Tutte le misure sono espresse in millimetri

# POMPE DI SENTINA MANUALI

## GUSHER® URCHIN > POMPA DI SENTINA E DI TRAVASO ACQUE DI SCARICO



- **TRE VERSIONI:**  
modelli con manico fisso, manico sfilabile e passa-paratia
- Fascetta bloccaggio membrana di facile rimozione per orientare i raccordi acqua e per la manutenzione
- Le ridotte dimensioni sono ideali per spazi ristretti
- Realizzazione robusta e leggera
- L'azionamento dolce consente una portata fino a 55 lit/min
- Raccordi con due diametri per tubi da 25 mm o da 38 mm
- Adatta all'impiego su barche medio piccole
- La membrana in nitrile (optional) la rende adatta al travaso di gasolio (kit di manutenzione AK9011)

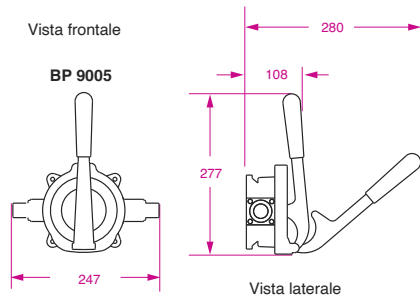

### Utilizzi tipici

- Pompa di sentina di emergenza
- Svuotamento serbatoi
- Scarico WC



	BP 9005	BP 9013	BP 9021	
<b>Modello</b>	maniglia fissa	da incasso/a paratia	maniglia rimovibile	
<b>Peso</b>	0,6 Kg	0,96 Kg	0,7 Kg	
<b>Connessioni tubi</b>	Portagomma Ø 25 mm e Ø 38 mm			
<b>Materiali</b>	Corpo della pompa: polipropilene rinforzato, Ghiera: acetato - Membrana: Neoprene (disponibile anche in Nitrile) - Maniglia, molla e viteria: acciaio inox			
<b>Materiali a contatto con i fluidi</b>	Polipropilene rinforzato, Nitrile, Neoprene, acciaio inox			
<b>Kit di manutenzione</b>	AK9003 - Parti in Neoprene – AK9011 - Parti in Nitrile per olio e gasolio. Contiene: Membrane, Valvole e clips circolari			
<b>Accessori</b>	AS8680: Maniglia estraibile di ricambio (per BP 9013 e BP 9021) AS8681: Maniglia fissa di ricambio (per BP9005)			
<b>Aspirazione massima</b>	4 m			
<b>Prevalenza massima</b>	3 m			
<b>DATI PRESTAZIONE</b>				
	<b>Aspirazione</b>			
<b>Tubo</b>	<b>25 mm</b>		<b>38 mm</b>	
<b>Aspirazione</b>	1 m	2 m	1 m	2 m
<b>Prevalenza</b>	0,5 m	0,5 m	0,5 m	0,5 m
<b>45 colpi al minuto</b>	25 litri	25 litri	37,5 litri	36 litri
<b>70 colpi al minuto</b>	43 litri	40 litri	55 litri	53 litri

BP 9005	manico fisso	<b>cod. 13.01.00003</b>
BP 9013	da incasso / a paratia con passacoperta	<b>cod. 13.01.00004</b>
BP 9021	manico staccabile	<b>cod. 13.01.00005</b>

### ACCESSORI – PASSA COPERTA PER POMPE DI SENTINA

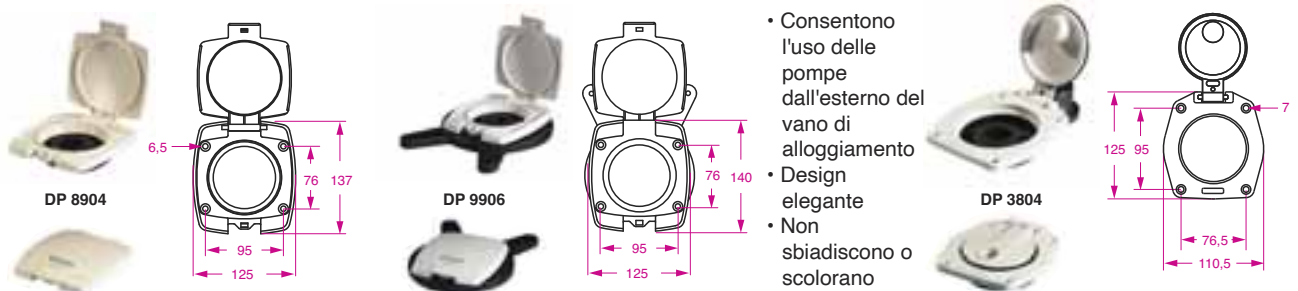

	DP 8904	DP 9906	DP 3804 - AS 3020
<b>Materiali</b>	in plastica a 4 fori PBT	in plastica a 4 fori PBT	metallico a 4 fori Alluminio pressofuso LM6
<b>DP 8904</b>	con portello – per pompe Gusher® 10, Gusher® Titan, Gusher® Urchin		peso 170 g <b>cod. 13.10.00017</b>
<b>DP 9906</b>	con portello – per pompe Mk 5 e BP 0510		peso 552 g <b>cod. 13.10.00004</b>
<b>DP 3804</b>	con portello – per pompe Gusher® 10		peso 380 g <b>cod. 13.10.00002</b>
<b>AS 3020</b>	con portello – per pompe Gusher® 30		peso 732 g <b>cod. 13.10.00001</b>

Tutte le misure sono espresse in millimetri

ACCESSORI

Valvola deviatrice studiata per l'uso negli impianti di sentina e WC



Utilizzi tipici

- Robusta ed affidabile
  - Azionamento morbido grazie al Teflon® lubrificato
  - Lavorata con precisione per garantire la tenuta agli odori
  - Resiste alle acque grigie ed a quelle nere, all'acqua di mare e all'acqua di sentina
  - Risponde ai requisiti della Guardia Costiera U.S.A. per impianti di scarico di tipo III
  - Disponibile per il collegamento a tubi Ø 25 mm (DV5630) o Ø 38 mm (DV5606)
- 
- Adatte a impianti di scarico elettrici e manuali
  - Utilizzate negli impianti di scarico di sentina e di WC
  - Consentono di aspirare con una sola pompa da due punti diversi
  - Devia il flusso verso un serbatoio di raccolta o fuori bordo
  - Devia il flusso dal serbatoio di raccolta al raccordo di aspirazione

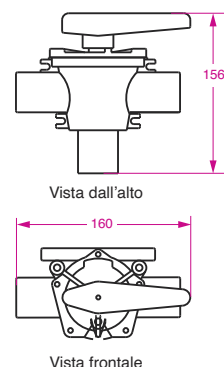

	DV 5630	DV 5606
<b>Voltaggio</b>	12 V CC	24 V CC
<b>Raccordi tubi</b>	Ø 25 mm	Ø 38 mm
<b>Materiali</b>	Corpo principale: Acetato, Teflon® - Maniglia: poliestere PTFE	

<b>DV 5630</b>	Valvola deviatrice per tubi da 1"	connessioni tubi Ø 25 mm	peso 475 g	<b>cod. 13.10.00018</b>
<b>DV 5606</b>	Valvola deviatrice per tubi da 1" 1/2	connessioni tubi Ø 38 mm	peso 557 g	<b>cod. 13.10.00005</b>

ACCESSORI DI SCARICO

Succhiarole ideali per l'uso negli impianti di sentina

SB 5865



- Evitano che corpi solidi entrino nel tubo di aspirazione
- La piastra filtro smontabile facilita la pulizia
- Disponibili versioni con aspirazione superiore o laterale
- La succhiarola con attacco dall'alto è ideale per sentine profonde, quello con attacco laterale per le sentine più basse
- Utilizzabili con tubi Ø 25 o Ø 38 mm
- Dotate di valvola di non ritorno per impedire il reflusso in sentina
- In Polipropilene

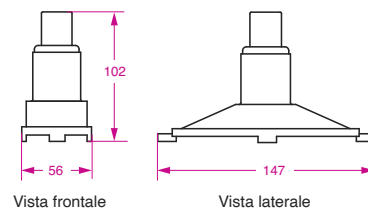

SB 4222

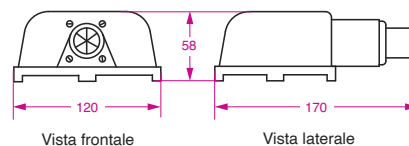

<b>SB 4222</b>	Per tubi da 1" e 1" 1/2, orizzontale	Uscita Ø 25 mm	peso 150 g	<b>cod. 13.10.00010</b>
<b>SB 5865</b>	Per tubi da 1" e 1" 1/2, verticale	Uscita Ø 38 mm	peso 101 g	<b>cod. 13.10.00011</b>

Attacco orientabile a 4 posizioni



- Evita che corpi solidi entrino nel tubo di aspirazione
- Filtro accessibile premendo due pulsanti sul corpo
- L'attacco per il tubo può essere variato a scelta fra orizzontale, verticale e laterale
- Adatta a tubi Ø 19 mm (3/4")
- Dotata di valvola di non ritorno per impedire il reflusso in sentina

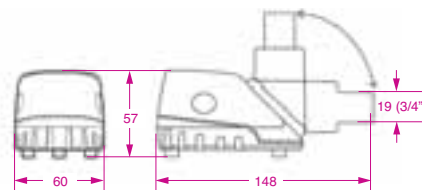

<b>SB 3422</b>	orientabile	peso 137 g	<b>cod. 13.10.00019</b>
----------------	-------------	------------	-------------------------

Tutte le misure sono espresse in millimetri



## POMPE DI SENTINA ELETTRICHE AD IMMERSIONE

ORCA > COMPATTE E POTENTI



- Elevate prestazioni
- Semplici da installare - diverse posizioni per i cavi
- Conformi allo standard marino ISO8849
- Il basso consumo assicura una lunga durata della batteria
- Facile manutenzione - Cartuccia del motore e area filtro accessibili
- Design compatto
- Robusta custodia in ABS resistente ai carburanti
- L'ampia base del filtro assicura la massima superficie esposta all'acqua
- Portata: 32 lit/min
- Ispezione rapida senza staccare il tubo di scarico

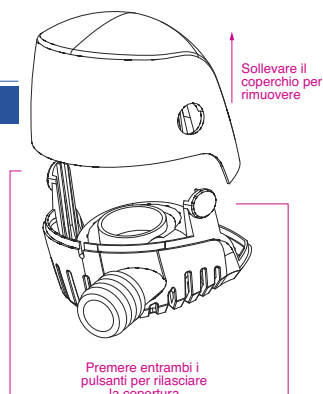

	BE 0500	BE 0950	BE 1450	BP 1454
Portata a 13,6 V C.C aperto	32 l/min	57 l/min	82 l/min	
Portata con prevalenza di 1 m	26 l/min	52 l/min	65 l/min	
Assorbimento		12 V CC		24 V CC
Consumo di corrente	1,5 A	3,5 A	5,0 A	2,5 A
Fusibile raccomandato tipo auto	2,0 A	5,0 A	7,0 A	5,0 A
Peso	0,28 kg	0,45 kg	0,82 kg	
Raccordi tubi	Ø 19 mm	Ø 29 mm		
Sezione fili	1,5 mm <sup>2</sup> x 1 m			
Materiali	Corpo pompa: ABS - Guarnizioni: Nitrile - Girante: Acetato			
Prelevanza massima	3 m	3,5 m	4,5 m	
Altezza fuori tutto	83 mm	109 mm	129 mm	
Larghezza fuori tutto	102 mm	135 mm	168 mm	
Profondità fuori tutto	78,5 mm	103 mm	121 mm	

BE 0500	12 Volt	<b>cod. 13.01.10003</b>
BE 0950	12 Volt	<b>cod. 13.01.10004</b>
BE 1450	12 Volt	<b>cod. 13.01.10005</b>
BE 1454	24 Volt	<b>cod. 13.01.10006</b>

## POMPE DI SENTINA ELETTRICHE AUTOADDESCANTI

GULPER® 320 > POMPA PER DRENAGGIO DOCCIA, ACQUE GRIGIE E SENTINE



ATTENZIONE: la Gulper® 320 non è adatta al pompaggio del gasolio. Per informazioni su questo tipo di applicazioni contattare la Whale

- Pompa anche l'acqua con residui difficili come i capelli
- Facile manutenzione - Valvole non intasabili
- Auto adescante fino a 3 m - Basso consumo
- Può funzionare a secco senza danneggiarsi
- Può pompare acqua mista ad aria
- Robusta ed affidabile - Non richiede filtri
- Pompa fino a 19 litri al minuto con scarico libero
- Funzionamento silenzioso
- Portagomma diametro 19 mm (3/4") e 25 mm (1")
- La nuova Gulper® 320 ha una portata del 35% superiore rispetto a quella della Gulper® 220
- I raccordi acqua orientabili facilitano il montaggio
- Possibilità di montaggio in posizioni facilmente accessibili

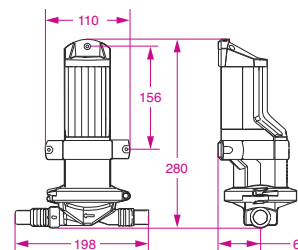

### Utilizzi tipici

- Drenaggio docce e lavandini
- Ricircolazione acqua nella vasca delle esche
- Drenaggio e circolazione serbatoi

BP 2054 (24 Volt)				
Voltaggio	24 V CC			
Fusibile raccomandato	8 A			
Peso	1,5 Kg			
Raccordi tubi	Ø 19 mm e Ø 25 mm			
Materiali	Corpo pompa: Nylon rinforzato - Ghiera: Acetato - Membrana e valvole: Santoprene® Piedini: EPDM - Ingranaggio: Delrin® - Viteria: acciaio inox, ottone			
Materiali a contatto coi fluidi	Nylon rinforzato, Nitrile, Santoprene®, acciaio inox			
DATI PRESTAZIONE				
Diametro tubo	19 mm	25 mm	19 mm	25 mm
Aspirazione	0 m	0 m	1 m	1 m
Prevalenza	1 m	1 m	1 m	1 m
Portata al minuto	19 litri	17,5 litri	17,4 litri	15,5 litri
Assorbimento di corrente	7,5 A	8 A	7,5 A	8 A

BP 2054 24 Volt **cod. 13.01.20004**

Tutte le misure sono espresse in millimetri

## POMPE DI SENTINA ELETTRICHE AUTOADDESCANTI

### GULPER® 220 > POMPA PER DRENAGGIO DOCCIA, ACQUE GRIGIE E SENTINE



ATTENZIONE: la Gulper® 220 non è adatta al pompaggio del gasolio. Per informazioni su questo tipo di applicazioni contattateci

- Pompa anche l'acqua con residui difficili come i capelli nelle docce
- Valvole non intasabili
- Auto adescante fino a 3 m
- Può funzionare a secco senza danneggiarsi
- Può pompare acqua mista ad aria
- Robusta ed affidabile
- Pompa fino a 14 lit/min con scarico libero
- Non richiede filtri
- Funzionamento silenzioso
- I raccordi acqua orientabili facilitano il montaggio della pompa
- Basso consumo

#### Utilizzi tipici

- Drenaggio docce e lavandini
- Ricircolazione acqua nella vasca delle esche
- Drenaggio e circolazione serbatoi

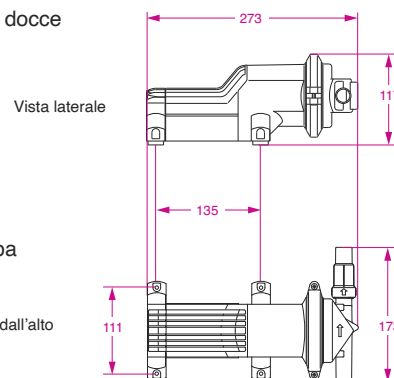

	BP 1552	BP 1554
<b>Voltaggio</b>	12 V CC	24 V CC
<b>Fusibile raccomandato</b>	5 A	2,5 A
<b>Peso</b>		1,5 Kg
<b>Raccordi tubi</b>		19 mm
<b>Sezione dei fili</b>		1,5 mm <sup>2</sup>
<b>Materiali</b>	Corpo pompa: Nylon rinforzato - Ghiera: Acetato - Membrana e valvole: Santoprene®	
<b>Materiali a contatto coi fluidi</b>	Nylon rinforzato, Nitrile, Santoprene®, acciaio inox	
<b>Accessori</b>	GW0810 / GW1610: Serbatoi per acque grigie	
<b>Kit di manutenzione</b>	AK1550: Kit di manutenzione per Gulper® 220 – Contiene: Membrana e valvole	
<b>Aspirazione massima</b>	3 m	
<b>Prevalenza massima</b>	3 m	
<b>Prevalenza e pescaggio massimi</b>	4 m	
<b>Corrente di funzionamento a vuoto</b>	2,4 A	1,2 A
<b>DATI PRESTAZIONE</b>		
<b>Pescaggio</b>	0 m	1 m
<b>Prevalenza</b>	1 m	1 m
<b>Portata al minuto</b>	3,4 litri	12,6 litri
<b>Assorbimento di corrente</b>	3,5 A (12 V CC) – 1,75 A (24 V CC)	4 A (12 V C.C) – 2 A (24 V CC)

BP 1552	12 Volt	<b>cod. 13.01.20001</b>
BP 1554	24 Volt	<b>cod. 13.01.20002</b>

### SWIM 'N' RINSE > DOCCIA DI POPPA > CON MISCELATORE DOCCIA DA ESTERNO



- Il telefono doccia consente la modifica del getto (spruzzo o pieno)
- Si collega direttamente ai raccordi rapidi Speedfit da 15 mm
- Foro di montaggio 125 mm X 250 mm

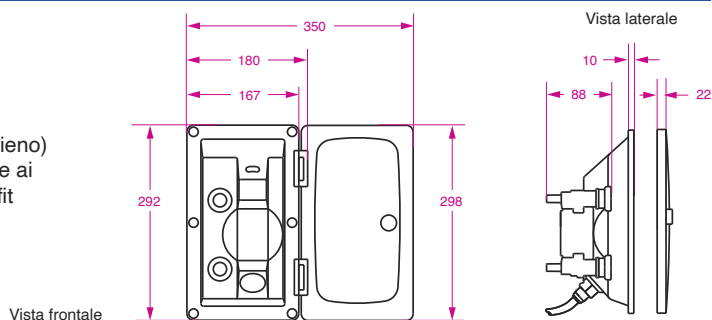

	RT 2658
<b>Colore</b>	bianco
<b>Piastra di base</b>	167 mm x 292 mm
<b>Profondità d'incasso</b>	Ø 88 mm
<b>Raccordo tubo</b>	1/2" F GAS
<b>Connessione Speedfit</b>	CM 3201S: Adattatore femmina 1/2" – 15 mm
<b>Lunghezza tubo</b>	2,1 m

RT 2658	(con coperchio)	peso 1,226 Kg	<b>cod. 13.05.00006</b>
---------	-----------------	---------------	-------------------------

Tutte le misure sono espresse in millimetri

## POMPE PER LAVELLI

### GUSHER® GALLEY MK 3 > POMPA A PEDALE



Nota: non tenere in pressione se usata in parallelo ad autoclavi

- Impianto per acqua dolce o salata a basso costo per rubinetti e docce
- Ideale come pompa di riserva per impianti con pompa elettrica
- Le connessioni multi direzionali dei tubi di entrata ed uscita rendono più facile l'installazione
- Tre opzioni di montaggio compresa quella attraverso la paratia
- Può essere utilizzata per innescare le pompe ausiliarie in linea Whale

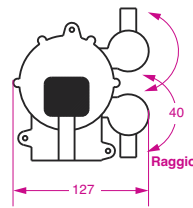

Vista frontale

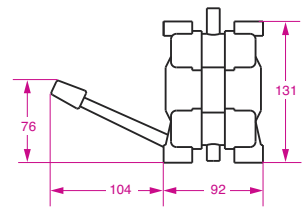

Vista laterale

Montaggio leva	destro
Peso	0,7 Kg
Raccordi tubi	Adatta al collegamento con innesto rapido Whale Ø 15 mm, tubo flessibile Ø 13 mm
Materiali	Corpo pompa: Acetato, Nylon. Membrana: Nitrile, Neoprene, Fascette: acciaio inox
Kit di manutenzione	AK0553 - Kit di manutenzione per Gusher® Galley (adatto solo per Mk 3)
Aspirazione massima	2 m
Prelevanza massima	3 m
Portata massima al minuto	15 litri

GP 0550

cod. 13.02.00003

### POMPA BABYFOOT® > POMPA A PIEDE AUTOADDESCANTE



- Azionamento facile ed agevole
- Compatta e di semplice installazione
- Ideale per installazioni dove lo spazio è limitato
- Il suo design inclinato ne rende più comodo l'uso
- Ideale come pompa di innescò per le pompe elettriche in linea Whale
- Adatta per acqua dolce e salata

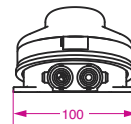

Vista frontale

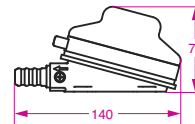

Vista laterale

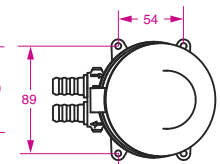

Vista in pianta

Portagomma tubi	adatta a tubo flessibile Ø 13 mm
Peso	0,3 Kg
Materiali	Corpo della pompa: Nylon - Bocchettoni: Acetato - Guarnizioni: Neoprene Fascette: acciaio inox, bronzo al fosforo
Kit di manutenzione	AK4615: Kit di manutenzione per pompa Babyfoot® Contiene: Membrana valvole, O Rings, molla, Fascette
Aspirazione massima	1,5 m
Prelevanza massima	3 m
Portata massima al minuto	8 litri

GP 4618

cod. 13.02.00005

### GOMITI – IDEALI NELLE INSTALLAZIONI IN SPAZI RISTRETTI GIUNTI PER TUBAZIONI

- Per raccordi di pompe a mano
- In polipropilene rinforzato



EB 3364	per pompe Gusher® Urchin e tubi da 1" (25 mm)	peso 43 g	cod. 13.10.00006
EB 3488	per pompe Gusher® Urchin e Titanic, tubi da 1" 1/2 (38 mm)	peso 65 g	cod. 13.10.00007

### VALVOLE DI NON RITORNO

Utili per mantenere l'innescò negli impianti con pompe in linea

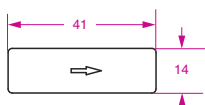

- Ideali per l'uso con pompe elettriche

Connessioni	adatte a tubi flessibili Ø 13 mm
Peso	4 grammi
Materiali	Corpo: ABS, ottone cromato - Molla: bronzo al fosforo - Guarnizione: nitrile

FV 1227

cod. 13.02.10009

Tutte le misure sono espresse in millimetri

**POMPA ELETTRICA  
AD IMMERSIONE COMPATTA**

**POMPA ELETTRICA  
AUSILIARIA IN LINEA**



**GP 1352 - GP 1354**

- Per acqua dolce e salata
- Adatta all'uso in impianti con pressostato e microswitch

**GP 1392 - GP 1394**

- Funzionamento silenzioso
- Leggera e portatile
- Economico potenziamento di un impianto idraulico manuale
- Ideale per acqua dolce e salata
- Adatta all'uso in impianti con pressostato e microswitch
- Può essere sostenuta dallo stesso tubo di alimentazione
- Deve essere montata sotto battente o adescata con una pompa meccanica



	<b>GP 1352 – GP 1392</b>	<b>GP 1354 – GP 1394</b>
<b>Voltaggio</b>	12 V CC	24 V CC
<b>Fusibile raccomandato</b>	5 A	3 A
<b>Peso</b>	0,16 Kg	
<b>Raccordi tubo</b>	Adatti a tubi flessibili Ø 10 mm o Ø 13 mm	
<b>Per innesto rapido Speedfit</b>	Usare WX 1511 (gambo adattatore 11 mm - 15 mm) e quindi PEM 0415 (15 mm dritto)	
<b>Materiali</b>	Corpo pompa: ABS - Guarnizione: Nitrile - Filtro: Polipropilene - Girante: Acciaio inox	
<b>DATI PRESTAZIONE</b>		
<b>Prevalenza</b>	<b>Portata al minuto - Consumo di corrente</b>	
0 m	13,2 litri – 3,6 A	13,2 litri – 1,8 A
1 m	11,75 litri – 3,3 A	11,75 litri – 1,6 A
3 m	9,75 litri – 2,9 A	9,75 litri – 1,45 A

<b>GP 1352</b>	12 Volt	<b>cod. 13.02.10001</b>
<b>GP 1354</b>	24 Volt	<b>cod. 13.02.10002</b>
<b>GP 1392</b>	12 Volt	<b>cod. 13.02.10004</b>
<b>GP 1394</b>	24 Volt	<b>cod. 13.02.10005</b>

**UNIVERSAL > GAMMA DI AUTOCLAVI AUTOMATICHE PER ACQUA DOLCE**



- Autoadescante fino a 3 m
- Flusso costante ed omogeneo
- Può girare a secco senza danni
- Funzionamento silenzioso
- Adatte a pompare sia acqua dolce che salata
- Filtro di ingresso incluso
- Dispositivo di montaggio universale adatto a qualsiasi impianto esistente

- Elevata protezione e sicurezza con cavi e pressostato disposti internamente

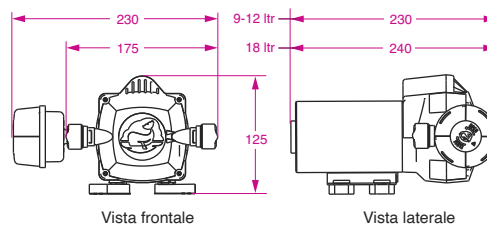

	<b>UF 0815</b>	<b>UF 1815</b>
<b>Portata al minuto (aperto)</b>	8 litri	18 litri
<b>Voltaggio</b>	12 V CC	
<b>Fusibile raccomandato</b>	8 A	
<b>Peso</b>	2,9 Kg	
<b>Raccordi tubi</b>	Innesto rapido da 15 mm femmina	3/4" M GAS
<b>Raccordo rapido Ø 15 mm</b>	NESSUN ADATTATORE RICHIESTO	per l'innesto rapido da 15 mm usare PEM 3203W (non fornito con pompa)
<b>Raccordi aggiuntivi</b>	3/4" adattatori flessibili x 2 (forniti)	
<b>Sez. minima dei conduttori elettrici</b>	2,5 mm <sup>2</sup>	
<b>Pressione d'esercizio</b>	3 bar	
<b>Materiali</b>	Corpo pompa: polipropilene rinforzato, carcassa motore: alluminio, membrana in acciaio speciale, Valvole, piedini: Monprene®, guarnizioni: Nitrile, fascette: acciaio inox	
<b>Materiali in contatto con i fluidi</b>	polipropilene rinforzato, Monprene®, Nitrile, acciaio inox	
<b>Kit di manutenzione</b>	AK1316 testa di ricambio – AK1317 microswitch – AK1319 filtro di ricambio	
<b>Aspirazione massimo</b>	3 m	
<b>Prevalenza massima</b>	30 m	

<b>UF 0815</b>	8 litri/min	12 Volt	3 bar	<b>cod. 13.02.10010</b>
<b>UF 1815</b>	18 litri/min	12 Volt	3 bar	<b>cod. 13.02.10012</b>

Tutte le misure sono espresse in millimetri

## WATER WITCH

INTERRUTTORI ELETTRONICI PER POMPE / ELECTRONIC SWITCH FOR BILGE PUMPS > WW

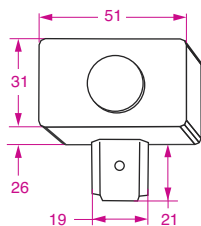

**WW101/12** 15 A / 12 Volt

**cod. 13.25.00004**

**WW101/24** 10 A / 24 Volt

Peso / Weight 119 g

**cod. 13.25.00005**

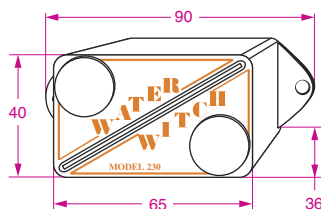

**WW230/24** 15 A / 24 Volt

Peso / Weight 166 g

**cod. 13.25.00003**

### MONTAGGIO / ASSEMBLY

Montare il **WATER WITCH** circa 3 cm sopra il livello normale dell'acqua, con i cavi di alimentazione che escono verso l'alto. Accertarsi che i contatti di connessione con pompa e batteria siano sopra il livello raggiungibile dall'acqua. Il modello 101 può anche essere fissato sulla pompa tramite una fascetta che abbraccia il corpo o quella che fissa il tubo di scarico. Il secondo sensore è costituito dalla staffa di fissaggio.

**WATER WITCH** lower sens must be installed above the residual water level with wires coming out from top. Check that the connections with the pump and the battery are well over the level water can reach. The pictures show two possible mounting of the 101 **WATER WITCH**

### COLLEGAMENTI ELETTRICI / ELECTRICAL CONNECTIONS

Il cavo rosso va collegato al polo positivo della batteria tramite un fusibile di valore pari a quello suggerito per la pompa. Il cavo nero va collegato a massa (polo negativo della batteria). Il cavo marrone al cavo positivo di alimentazione della pompa. **ATTENZIONE:** se collegato a massa (negativo della batteria), può danneggiare il **WATER WITCH**. Per poter azionare manualmente la pompa, collegare il cavo positivo di alimentazione della pompa al positivo della batteria, tramite un interruttore. Ogni volta che viene collegato alle batterie **WATER WITCH** aziona la pompa per alcuni secondi per autocalibrarsi. È possibile collaudare il funzionamento appoggiando un panno bagnato su entrambi i sensori.

1. Disconnect the battery.
2. Select a mounting location for the **WATER WITCH**; the lower water sensor, must be above the residual water level.
3. Always keep the wire connections above the highest water line.
4. Connect the wires in the following order following the wiring diagram below
5. From the **WATER WITCH** connect the brown to the Positive (+) side of the pump or device being controlled, connect the Black to the Ground or the Negative (-) side of the battery and connect the Red to the Positive (+) side of the battery through a fuse.
6. Reconnect the battery and the pump will run approximately 3 seconds while the switch self-calibrates.
7. WHENEVER POWER IS APPLIED, THE SWITCH RUNS THE PUMP FOR 3 SECONDS TO SELF-CALIBRATE.
8. To test, apply a wet rag across the two sensors on the front of the unit.

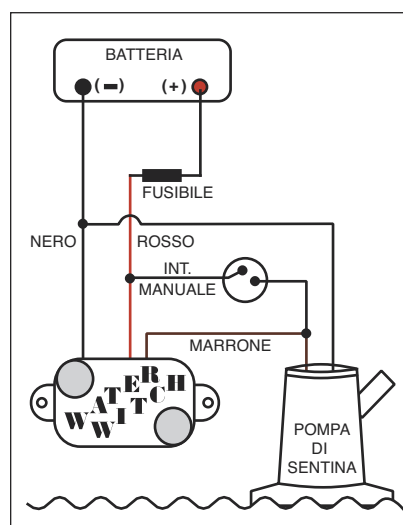

Tutte le misure sono espresse in mm / All measurements are in millimeters

**ELETTRONICI**  
Nessun bloccaggio del galleggiante causato dalle scorie  
**ECOLOGICI**  
Mercurio assente  
**CONSUMO IRRISORIO**  
0,004 Ampere (a riposo)  
**ACCENSIONE RITARDATA DI 6/8 secondi**  
Eliminati gli avviamenti dovuti a sciacquo  
**SPEGNIMENTO RITARDATO DI 14/16 secondi**  
Drenaggio completo dell'acqua  
**ELETTRODI ANTIADERENTI**  
Nessun problema causato da morchie e schiume  
**DIMENSIONI COMPATTE**  
Facilità di montaggio in qualunque posizione

**ELECTRONIC**  
Debris in the bilge will not damage the Water Witch  
**INSIGNIFICANT CONSUMPTION**  
0,004 Amp (at rest)  
**SWITCH ON DELAYED of 6/8 seconds**  
Prevent pump cycling due to sloshing  
**SWITCH OFF DELAYED of 14/16 seconds**  
Complete pump off  
**STAINLESS STEEL SENSORS**  
No problems due to froth or foams  
**COMPACT SIZE**  
Easy mounting even in restricted locations

Mediante un circuito elettronico, **WATER WITCH** aziona la pompa di sentina quando l'acqua bagna i sensori per almeno 6/8 secondi e, per drenare completamente l'acqua, la pompa continua a funzionare per altri 14/16 secondi dopo che il livello è sceso sotto i sensori. Il ritardo in accensione previene il funzionamento alternato della pompa, causato dallo sciacquo dell'acqua.

By means of an electronic circuit, the **WATER WITCH** activates the bilge pump when the water wets the sensors for about 6/8 seconds. The delay avoids pump stutter and once water has left the sensor, the switch continues to run the pump for additional 14/16 seconds to clear the output hose.



## VASI D'ESPANSIONE / ACCUMULATORS

### VASO D'ESPANSIONE PER POMPE AUTOCLAVI / ACCUMULATOR FOR PRESSURE PUMPS > AFC/2L

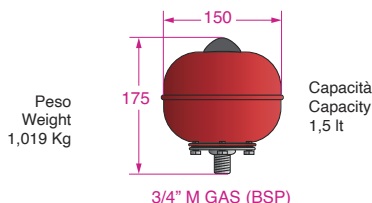

Corpo in acciaio,  
protetto con vernici epossidiche.

Steel body,  
coated with epoxy paints.

AFC/2L

cod. 13.30.00002

### VASO D'ESPANSIONE PER POMPE AUTOCLAVI / ACCUMULATOR FOR PRESSURE PUMPS > AFC/2T

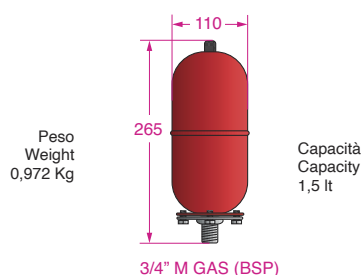

Corpo in acciaio,  
protetto con vernici epossidiche.

Steel body,  
coated with epoxy paints.

AFC/2T

Raccordo in acciaio zincato / Connection in galvanized steel

cod. 13.30.00001

AFC/2T-ss

Raccordo in acciaio inox / Connection in stainless steel

cod. 13.30.10001

### VASO D'ESPANSIONE PER POMPE AUTOCLAVI / ACCUMULATOR FOR PRESSURE PUMPS > AFC/5T

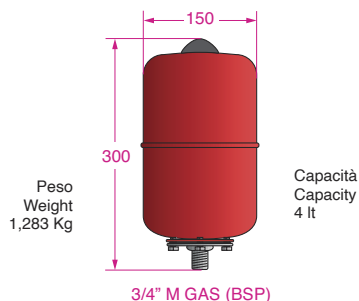

Corpo in acciaio,  
protetto con vernici epossidiche.

Steel body,  
coated with epoxy paints.

AFC/5T

Raccordo in acciaio zincato / Connection in galvanized steel

cod. 13.30.00004

AFC/5T-ss

Raccordo in acciaio inox / Connection in stainless steel

cod. 13.30.10004

### VASO D'ESPANSIONE PER POMPE AUTOCLAVI / ACCUMULATOR FOR PRESSURE PUMPS > AFC/8T

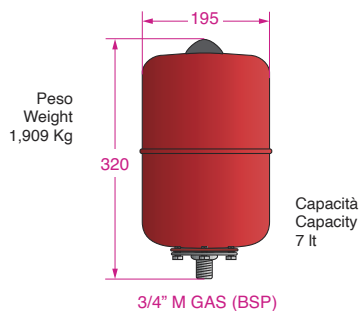

Corpo in acciaio,  
protetto con vernici epossidiche.

Steel body,  
coated with epoxy paints.

AFC/8T

Raccordo in acciaio zincato / Connection in galvanized steel

cod. 13.30.00007

AFC/8T-ss

Raccordo in acciaio inox / Connection in stainless steel

cod. 13.30.10007

Tutte le misure sono espresse in mm / All measurements are in millimeters

## PATTUMIERA COMPATTA IN ACCIAIO INOX

STAINLESS STEEL  
COMPACT WASTE BIN

Coperchio con  
apertura automatica  
Auto open lid

Cestino interno rimovibile  
Comodo e facile da pulire  
**Removable inner bin**  
Convenient and easy to clean



12,6 l 1,750 Kg



Resistente alla ruggine  
Rust-resistant



Resistente alle macchie  
Stain-resistant



Resistente alla corrosione  
Corrosion-resistant

PATSS2

cod. 99.01.00302

## FABBRICATORE DI GHIACCIO

SCOTSMAN > ACM 25

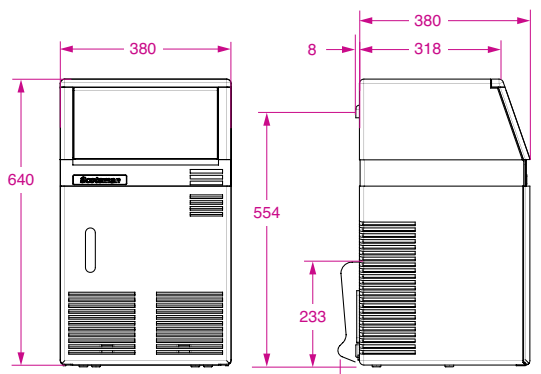

Peso / Weight 30 Kg

Vista frontale / Front view

Vista laterale / Side view

CAVO DI ALIMENTAZIONE

- Produzione di cubetti di forma troncoconica
- Alimentazione elettrica 230/50/1
- Non necessita di collegamento idraulico
- Serbatoio con caricamento acqua manuale.
- Indicatore livello acqua sul pannello frontale
- Produzione giornaliera di cubetti fino a 10 Kg (circa 500 cubetti)
- Capacità di stoccaggio ghiaccio fino a 3,5 Kg (circa 175 cubetti)
- Mobile in ABS
- Funzionamento con controlli elettromeccanici semplici ed affidabili
- Condensazione ad aria, con aspirazione e scarico frontali, adatto per installazioni ad incasso
- Sportello a scomparsa per facilitare il prelievo del ghiaccio
- Serbatoio trattato con "AgION", composto con proprietà antibatteriche
- Gas refrigerante R-134a CFCfree
- 2 anni di garanzia Scotsman sulle parti
- Capacità serbatoio acqua: 4 litri

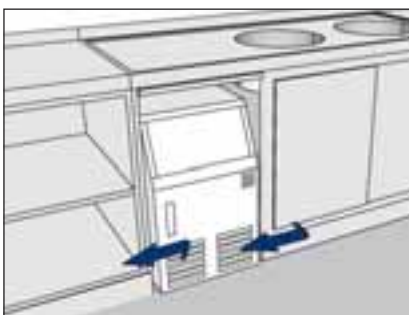
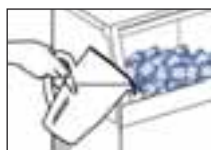
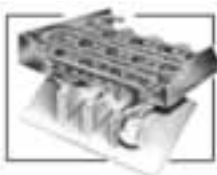

Il fabbricatore di ghiaccio **SCOTSMAN ACM 25** è la macchina ideale per l'utilizzo a bordo degli yacht. Il serbatoio incorporato lo rende infatti indipendente dall'impianto idraulico di bordo la cui acqua è spesso di qualità opinabile. Il riciclo dell'acqua non immediatamente trasformata in ghiaccio, oltre a rendere inutile l'impianto di scarico, consente il massimo risparmio del prezioso elemento. La ventilazione forzata dello scambiatore di calore assicura un funzionamento corretto anche in condizioni difficili, se l'apparecchio è correttamente installato. La carrozzeria in materiale plastico (ABS) color crema è naturalmente resistente all'ambiente marino e s'intona facilmente ai più sofisticati arredamenti. **I fabbricatori di ghiaccio Scotsman** sono progettati per garantire il regolare funzionamento anche in caso di installazioni a incasso. Infatti regolari flussi d'aria facilitano il raffreddamento.

Il sistema di produzione di **ghiaccio** in cubetti ha reso **Scotsman** famosa nel mondo. **I fabbricatori di ghiaccio Scotsman** sono realizzati in acciaio e in plastica, idonei per l'utilizzo con alimenti. Sono di facile accessibilità per eseguire le operazioni di pulizia.

ACM25

cod. 14.10.00001

Tutte le misure sono espresse in mm / All measurements are in millimeters

# CONDIZIONI GENERALI DI VENDITA

## ESTRATTO DELLE CONDIZIONI GENERALI DI VENDITA

- Le presenti condizioni si intendono valide e vincolanti nel loro complesso per ogni Ordine effettuato dall'acquirente e/o ogni rapporto di compravendita intercorrente tra le Parti.

### CONDIZIONI GENERALI

- Le Condizioni Generali potranno essere modificate e/o aggiornate, anche in base ad eventuali mutamenti normativi.

### CARATTERISTICHE DEI PRODOTTI E DOCUMENTI DESCRITTIVO-ILLUSTRATIVI

- Le caratteristiche e/o specifiche tecniche dei prodotti riportati su qualsiasi supporto incluso il sito web, avranno puro valore indicativo e non saranno vincolanti.

### ORDINE E CONFERMA D'ORDINE

- Per ordini inferiori a € 200,00 al netto di eventuali sconti ed IVA verrà applicato un costo fisso di gestione di € 10,00.
- Salvo immediata revoca la conferma d'ordine è vincolante per l'Acquirente.
- Tutte le offerte si considerano non vincolanti salvo espresso patto contrario.

### PREZZO

- I prezzi indicati si intendono franco magazzino al netto di imposte, eventuali spese di imballaggio, di trasporto, di assicurazione, doganali ed altri oneri fiscali.
- Barka s.r.l. si riserva il diritto di aggiornare periodicamente il prezzo dei prodotti.

### MODALITÀ DI PAGAMENTO

- Il pagamento anticipato dovrà essere effettuato entro 30 gg decorrente dalla conferma d'ordine, pena la cancellazione dell'ordine medesimo.
- In caso di mancato o ritardato pagamento verrà applicato il decreto legislativo del 9 Novembre 2012 n. 192: al Cliente saranno addebitati € 40 a titolo di risarcimento del danno (fatti salvi danni maggiori), mentre gli interessi di mora sono fissati nell'8% in più rispetto al tasso fissato dalla BCE per le operazioni di rifinanziamento.
- Gli interessi decorrono senza che sia necessaria la costituzione in mora.
- Qualora dall'ordine accettato e/o confermato la vendita debba effettuarsi ratealmente, l'Acquirente acquista la proprietà dei prodotti con il pagamento dell'ultima rata del prezzo, ma assume i rischi dal momento della consegna e pertanto in caso di furto, di danneggiamento, di incendio e di ogni altro caso fortuito, l'Acquirente sarà tenuto a pagare a Barka l'intero prezzo.
- In caso di mancato pagamento di due o più rate, anche non consecutive, che eccedono complessivamente l'ottava parte del prezzo dovuto per parte capitale Barka avrà diritto di ottenere l'immediata restituzione dei prodotti ivi inclusi tutti i documenti inerenti ai prodotti.
- Rimane fermo del pari il diritto di Barka ad ottenere la decadenza dell'Acquirente dal beneficio del termine. In tal caso l'Acquirente dovrà versare immediatamente l'intero prezzo pattuito.
- Inoltre, il ritardato pagamento di una sola rata darà diritto a Barka di sospendere l'adempimento di altri eventuali obblighi contrattuali assunti per differenti forniture nei confronti dell'Acquirente.

### RESI

- Eventuali resi di prodotti devono essere preventivamente autorizzati: la richiesta va inoltrata per iscritto tramite apposito modulo fornito da Barka e deve riportare in dettaglio il vizio o il difetto riscontrato e gli estremi della fattura d'acquisto.
- Se la richiesta di reso viene accettata, Barka fornirà un numero di Autorizzazione al Reso (RMA): tale numero dovrà essere indicato sia sulla bolla di reso sia sull'imballo ed in assenza di tale indicazione il reso sarà respinto.
- I prodotti oggetto di reso non devono essere utilizzati o danneggiati e devono essere restituiti nella loro confezione originale.
- Nel caso di resi per accreditato sarà addebitato il 15% del valore dei prodotti con l'aggiunta di €10 di spese amministrative, eventualmente maggiorate dagli ulteriori costi intervenuti.

### TERMINI DI CONSEGNA E SPEDIZIONE

- I termini di consegna avranno valore puramente indicativo e eventuali ritardi nella consegna dei prodotti non potranno comportare in ogni caso alcuna responsabilità o risarcimento di danni in capo a Barka.
- La spedizione, fatto salvo patto contrario, è a carico di Barka e radddebitata all'Acquirente in fattura. Eventuali costi di sdoganamento sono a carico dell'Acquirente.
- È comunque facoltà di Barka non dare evasione all'ordine, anche se confermato, qualora l'Acquirente sia divenuto insolvente anche con riferimento ad altre forniture o nei confronti di altri fornitori, oppure siano diminuite le sue garanzie patrimoniali.
- In presenza di imballo integro, eventuali difetti o vizi dei prodotti dovranno essere denunciati per iscritto a Barka entro 8 giorni dalla consegna, a pena di decorrenza.
- Al momento della ricezione dell'ordine, se i beni o le scatole apparissero danneggiate, aperte o senza l'imballaggio e lo scotch originale Barka bisogna:
  - a. accettare la spedizione con riserva, specificando l'esatta ragione della riserva sulla bolla di consegna al momento della firma. Consigliamo di farlo ogni volta che si sospetti che l'imballo sia in qualche maniera danneggiato.
  - b. spedire immediatamente una comunicazione scritta sia a Barka sia allo spedizioniere, comunicando i danni riscontrati ed allegando una copia della bolla di consegna.
- Barka non risponderà di alcun danno subito durante il trasporto se quanto sopra non è rispettato scrupolosamente.
- Se la spedizione non è stata gestita da Barka, ma dall'Acquirente, i beni viaggiano a suo rischio e pericolo.

### DIRITTI DI PROPRIETÀ INTELLETTUALE

- L'Acquirente riconosce i Diritti di Proprietà Intellettuale di Barka.
- L'Acquirente si impegna a non eliminare, alterare o modificare i Marchi, i segni di identificazione dei prodotti e tutti i segni distintivi di Barka comunque nella disponibilità di Barka, apposti sui prodotti e/o sulle loro confezioni, nonché a non alterare i prodotti e a non apportare alcuna modifica alle singole confezioni e/o imballaggi.
- L'Acquirente si impegna a non depositare e/o registrare, direttamente e/o indirettamente, anche tramite terzi, marchi, nomi, ragioni sociali, nomi a dominio, comunque altri segni distintivi identici e/o simili e/o confondibili con quelli di Barka, comunque il cui uso è nella disponibilità di Barka.

### LEGGE APPLICABILE E FORO COMPETENTE

- Il rapporto di compravendita è regolato esclusivamente dalla Legge Italiana, in caso di controversie che non trovassero una soluzione concordata sarà competente il foro di Milano

# GENERAL CONDITIONS OF SALE AND SUPPLY

---

## **VALIDITY**

The present general sale and supply terms and conditions ("General Terms") shall apply to and be incorporated into any sales and supply agreement between BARKA S.r.l. (hereinafter, "BARKA") and the Client (hereinafter "the Client"). The application of any different term and condition whatsoever, even if applied by the Client pursuant to reference made to its own purchasing or contractual provisions, is expressly excluded. Any modification to the General Terms herein, shall be endorsed by BAKA in writing, which will have the right to establish specific different conditions in each offer, and such specific condition will prevail over the present General Terms.

## **OFFERS, ORDERS AND COMPLETION OF THE CONTRACT**

BARKA's offers are not binding nor mandatory. The orders shall be valid only if issued in writing and sent to BARKA, also by telefax or by e-mail, to the addresses communicated by BARKA itself. The contract will be settled when BARKA will receive client's order. After the order has been received, the order cannot be cancelled by the client, without BARKA's written acknowledgement. BARKA reserves the right to reject the order by written communication to the Client sent within 5 days from order's receipt.

## **CHARACTERISTICS OF THE PRODUCTS – MODIFICATIONS**

Any information or data relating to features and/or specifications of the Products contained in depliants, price lists, catalogues and similar documents, including BARKA's website, are indicative and not binding for BARKA; the Client will observe the instructions for the use of the Products contained in the BARKA's catalogues and/or website, which are binding for the Client.

## **PRICES AND PAYMENTS**

Unless otherwise expressly indicated, price has to be considered in Euros, for each unit of Product, net from VAT and net from packaging, custom, freight and transportation costs. Prices of the Products are indicated in the official price lists of BARKA, as updated from time to time. Contextually or afterwards the price list transmission, the Client may receive special selling conditions related to discounts, conditions and terms of payment and of goods returning, also contained in the order confirmation. Unless otherwise agreed, payment of Products must be done by cash at the time of delivery. Terms of payment are mandatory and therefore BARKA will not grant any discounts, reductions or rounded figures other than those indicated in the special selling conditions granted to the Client. Payment shall be due in total as agreed, even in case of delay in delivery or in case of damage or loss, partial or total, during the transportation, not depending by BARKA.

## **DELIVERY AND TRANSPORT**

Except for otherwise indicated, the products are sold Ex Works BARKA's factory. All costs related to the transportation of the products are born by the Client. Upon delivery to the Client, shipper, carrier or to whoever is in charge of the transportation and, in any case, when the Products leave BARKA's factory, the liability of whole or partial loss of the Products is transferred to the Client. If the Client will not comply with any of the terms and conditions of the supply or sale, even in part, or if it changes its name and/or its ownership, or in case the Client delays payments, even towards other creditors, BARKA shall have the right to stop any delivery and to change the payment terms. The packaging of the Products has to be intended as standard packaging. Extra or special packing must be required in advance by the Client and has to be confirmed by BARKA in writing and could determine an additional price.

## **WARRANTY**

BARKA gives a generic warranty for manufacturing fault of its products, for 12 months from the invoice date. The warranty consists on and is limited to the repairing or substitution of the defective component or of the single defective part, provided, however, that they prevent the correct Product functioning and provided also that they exist since the origin. The warranty does not cover and is not extended to defects or damages caused by the transport or caused by negligence in the use or by product direct or indirect manumission or caused by repairing, single components substitution, upkeeps made by non BARKA authorized subjects, or due to technical inexperience, or by way of any circumstances independent from BARKA will. The Client, pain the forfeiture of the guarantee, has to notify to BARKA the defectiveness or the defects eventually found, within 8 days from their appearance, and however not beyond 12 months from the invoice date. The Client has to verify the goods correspond to the law enforced in the goods destination country and it has to inform BARKA, in good time and however before the goods shipment, of the eventual changes to be brought. In this case, BARKA could reject the order or charge the heavier expense to the Client. Any damage to the Products or other personal or property's damage due to any Client's failure to comply with any BARKA's use instructions will be exclusively born by the Client.

## **GOODS RETURN**

Except for specific cases accepted in writing, BARKA does not accept any goods return. Before any return procedure, the Client has to make a written claim and the good return has to be previously authorized in writing by BARKA. Cost and expenses of the return are born by the Client and the goods are carriage paid to BARKA's factory. BARKA reserves the right to inspect the returned goods to verify the warranty applicability and, in case of verification of a fault due to BARKA, it will provide to substitute the defective products, or to issue a credit note, only if the warranty is still valid. On the contrary, the goods will be sent back to the Client with transport charges to be paid by the Client itself.

## **BARKA'S INTELLECTUAL PROPERTY**

The Client expressly recognizes that trademarks, commercial names or other distinctive marks on the goods are in the exclusive property of the BARKA and will not be altered, changed, removed or cancelled in any manner. The Client has the limited right to use trademarks, commercial names or other distinctive marks, as well as other industrial exclusive right or Know how (productive or commercial) associated with the goods - which nonetheless remain in the exclusive property of BARKA - to the limited purpose of the resale of the goods to the final consumer. Any other utilization of the BARKA Intellectual Property by the Client, if not expressly granted by BARKA in writing, will be considered an infringement of the exclusive rights of BARKA, and a breach of contract, and will be therefore prosecuted.

## **SALES WITH PROPERTY RESERVE**

BARKA reserves the ownership of the products, paid by installments or deferred and the ownership will be transferred to Client only on completion of the entire payment, ex Section 1523 of the Italian Civil Code, provided however that all the risks connected to the products are transferred to the Client at the delivery date.

## **GOVERNING LAW – JURISDICTION**

The sales contract shall be governed and construed in compliance with Italian law. The Court of Milano, Italy - shall have the exclusive jurisdiction in any dispute arising from or in connection with the sale or supply relationship, its agreement, performance or breach whatsoever.



**barka s.r.l.**

Strada Padana Superiore, 256/266  
20055 Vimodrone - Mi (Italy)  
Tel: +39.02.27.40.80.33

General information:

Informazioni generali  
info@barka.it

Commercial dept.:  
orders@barka.it

Ufficio commerciale  
ordini@barka.it

Technical and support dept.:  
support@barka.it

Ufficio tecnico e assistenza  
assistenza@barka.it

Accounting dept.:  
accounting@barka.it

Ufficio amministrativo e contabilità  
amministrazione@barka.it

Graphic department:

Ufficio grafico:  
grafica@barka.it





Strada Padana Superiore, 256/266  
20055 Vimodrone - MI (Italy)  
Tel: +39.02.27.40.80.33  
info@barka.it  
[www.barka.it](http://www.barka.it)